



PHYSICS

9792/01

Paper 1 Part A Multiple Choice

May/June 2012

1 hour 15 minutes

Additional Materials: Multiple Choice Answer Sheet
Soft clean eraser
Soft pencil (type B or HB is recommended)



READ THESE INSTRUCTIONS FIRST

Write in soft pencil.

Do not use staples, paper clips, highlighters, glue or correction fluid.

Write your name, Centre number and candidate number on the Answer Sheet in the spaces provided unless this has been done for you.

There are **forty** questions on this paper. Answer **all** questions. For each question there are four possible answers **A, B, C** and **D**.

Choose the one you consider correct and record your choice in **soft pencil** on the separate Answer Sheet.

Read the instructions on the Answer Sheet very carefully.

Each correct answer will score one mark. A mark will not be deducted for a wrong answer.

Any working should be done in this booklet

This document consists of **27** printed pages and **1** blank page.



Data

gravitational field strength close to Earth's surface	$g = 9.81 \text{ N kg}^{-1}$
elementary charge	$e = 1.60 \times 10^{-19} \text{ C}$
speed of light in vacuum	$c = 3.00 \times 10^8 \text{ m s}^{-1}$
Planck constant	$h = 6.63 \times 10^{-34} \text{ J s}$
permittivity of free space	$\epsilon_0 = 8.85 \times 10^{-12} \text{ F m}^{-1}$
gravitational constant	$G = 6.67 \times 10^{-11} \text{ N m}^2 \text{ kg}^{-2}$
electron mass	$m_e = 9.11 \times 10^{-31} \text{ kg}$
proton mass	$m_p = 1.67 \times 10^{-27} \text{ kg}$
unified atomic mass constant	$u = 1.66 \times 10^{-27} \text{ kg}$
molar gas constant	$R = 8.31 \text{ J K}^{-1} \text{ mol}^{-1}$
Avogadro constant	$N_A = 6.02 \times 10^{23} \text{ mol}^{-1}$
Boltzmann constant	$k = 1.38 \times 10^{-23} \text{ J K}^{-1}$
Stefan-Boltzmann constant	$\sigma = 5.67 \times 10^{-8} \text{ W m}^{-2} \text{ K}^{-4}$

Formulae

uniformly accelerated motion	$s = ut + \frac{1}{2}at^2$ $v^2 = u^2 + 2as$ $s = \left(\frac{u+v}{2}\right)t$	magnetic force	$F = BIl \sin \theta$ $F = BQv \sin \theta$
heating	$\Delta E = mc\Delta\theta$	electromagnetic induction	$E = \frac{-d(N\Phi)}{dt}$
change of state	$\Delta E = mL$	Hall effect	$V = Bvd$
refraction	$n = \frac{\sin\theta_1}{\sin\theta_2}$ $n = \frac{v_1}{v_2}$	time dilation	$t' = \frac{t}{\sqrt{1 - \frac{v^2}{c^2}}}$
photon energy	$E = hf$	kinetic theory	$\frac{1}{2}m\langle c^2 \rangle = \frac{3}{2}kT$
de Broglie wavelength	$\lambda = \frac{h}{p}$	work done on/by a gas	$W = p\Delta V$
simple harmonic motion	$x = A \cos \omega t$ $v = -A\omega \sin \omega t$ $a = -A\omega^2 \cos \omega t$ $F = -m\omega^2 x$ $E = \frac{1}{2}mA^2\omega^2$	radioactive decay	$\frac{dN}{dt} = -\lambda N$ $N = N_0 e^{-\lambda t}$ $t_{\frac{1}{2}} = \frac{\ln 2}{\lambda}$
energy stored in a capacitor	$W = \frac{1}{2}QV$	attenuation losses	$I = I_0 e^{-\mu x}$
electric force	$F = \frac{Q_1 Q_2}{4\pi\epsilon_0 r^2}$	mass-energy equivalence	$\Delta E = c^2 \Delta m$
electrostatic potential energy	$W = \frac{Q_1 Q_2}{4\pi\epsilon_0 r}$	hydrogen energy levels	$E_n = \frac{-13.6 \text{ eV}}{n^2}$
gravitational force	$F = \frac{-Gm_1 m_2}{r^2}$	Heisenberg uncertainty principle	$\Delta p \Delta x \geq \frac{h}{2\pi}$ $\Delta E \Delta t \geq \frac{h}{2\pi}$
gravitational potential energy	$E = \frac{-Gm_1 m_2}{r}$	Wien's law	$\lambda_{\text{max}} \propto \frac{1}{T}$
		Stefan's law	$L = 4\pi\sigma r^2 T^4$
		electromagnetic radiation from a moving source	$\frac{\Delta\lambda}{\lambda} \approx \frac{\Delta f}{f} \approx \frac{v}{c}$

- 1 A space probe is leaving a large asteroid. During the initial part of its journey, the weight of the probe in the asteroid's gravitational field does not change.

Which diagram shows the gravitational field line pattern close to the surface of the asteriod?

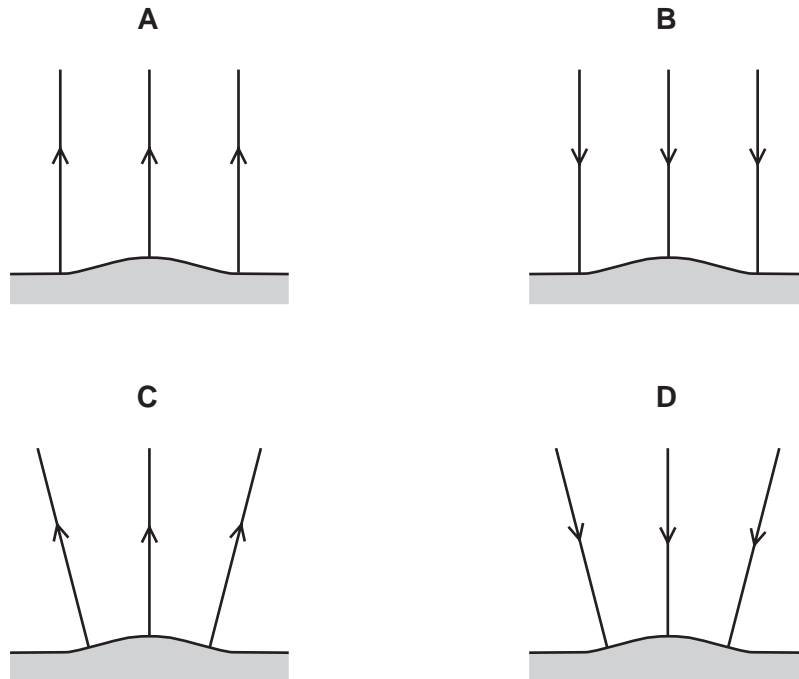

- 2 A swimmer dives off a diving board into a pool.

Which quantity will **not** affect the time she spends in the air before hitting the water?

- A acceleration due to gravity
- B air resistance
- C her horizontal velocity on leaving the board
- D the height of the board

Space for working

- 3 A student is studying Newton's third law of motion. He states that a rocket travelling in deep space can never accelerate because when the rocket's engines burn, the forwards force acting on the rocket is cancelled by an equal and opposite force.

Which statement explains why the student is wrong?

- A** The equal and opposite force does not act on the rocket.
B The equal and opposite force has a different line of action.
C The equal and opposite force is a reaction force.
D The equal and opposite force will be a different type of force.
- 4 Two masses are connected by a weightless cord passing over a frictionless pulley and released.

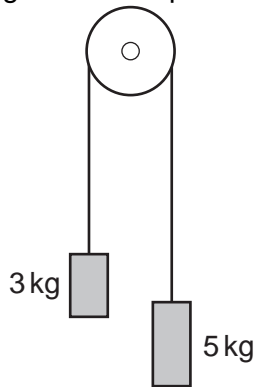

The acceleration due to gravity is g .

What is the magnitude of the acceleration of the masses?

- A** $\frac{g}{4}$ **B** $\frac{3g}{8}$ **C** $\frac{5g}{8}$ **D** g

Space for working

- 5 A water cannon directs a jet of water towards a vertical wall. 300 kg of water hit the wall each minute. The water hits the wall horizontally with a velocity 20 m s^{-1} . Assume the water falls vertically after hitting the wall.

What force does the water exert on the wall?

- A 100 N B 200 N C 3000 N D 6000 N

- 6 A force F is applied at an angle θ to a door, at a distance d from the hinge.

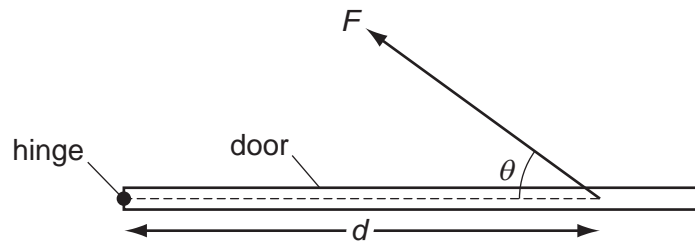

What is the moment of F about the hinge?

- A $Fd \sin \theta$ B $\frac{Fd}{\sin \theta}$ C $Fd \cos \theta$ D $\frac{Fd}{\cos \theta}$

Space for working

- 7 The graph shows how the horizontal displacement of a fairground car changes with time for part of its journey.

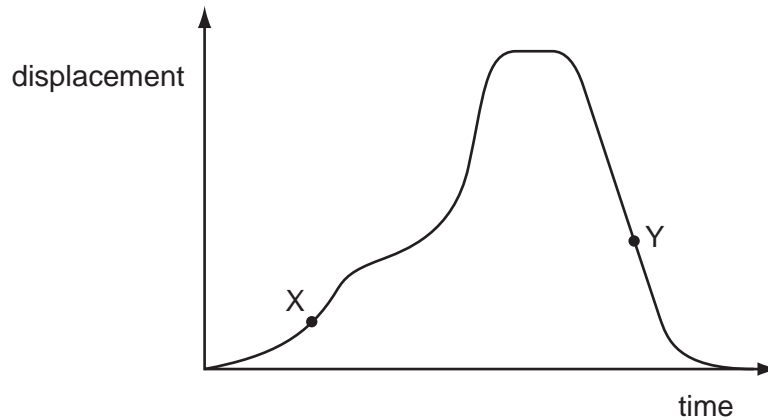

A simple accelerometer is made by sandwiching a rubber ring between two glass plates and introducing some coloured water inside the ring. The accelerometer is attached to the side of the car.

Diagram **B** corresponds to point X on the graph.

Which diagram shows the angle of water surface in the accelerometer at point Y?

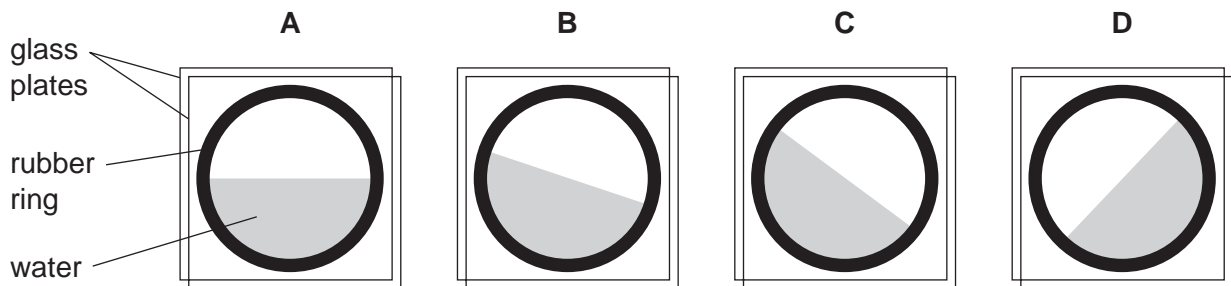

Space for working

- 8 A rock climber descends a cliff face by abseiling down it.

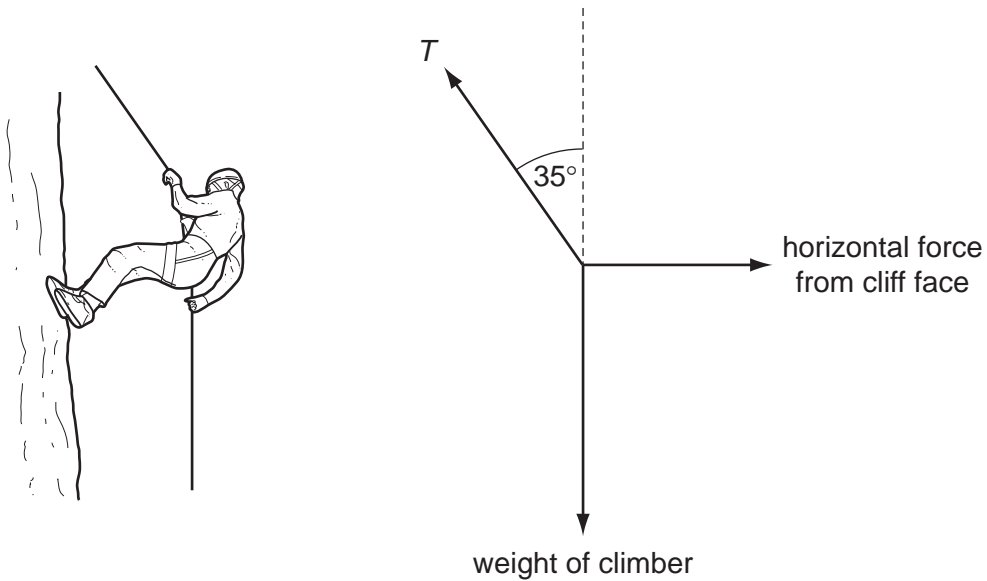

The mass of the climber is 64 kg.

At a time the climber pauses, the rope under tension is held at an angle of 35° to the vertical.

What is the magnitude of the horizontal force acting on the climber from the cliff face?

- A 300 N B 360 N C 440 N D 510 N
- 9 A particle moves with constant speed in a circle of radius r under the action of a constant force of magnitude F .

What is the work done by the force in one complete revolution of the particle?

- A Fr B $2\pi Fr$ C $\frac{Fr}{2\pi}$ D zero

Space for working

- 10 A dam is to be built across the Congo River in Africa. The water will fall through 150 m providing energy to operate a power station.

The rate at which the water falls is $26\,400\text{ m}^3\text{ s}^{-1}$.

What is the power delivered to the power station? Take the density of water as 1000 kg m^{-3} .

- A 0.0390 MW B 259 MW C 3960 MW D 39 000 MW

- 11 Water is pumped through a car engine in order to keep it at a constant temperature. The pump stops working, and the engine transfers energy to the water in the engine block at a rate of 100 kW. The volume of water in the engine block is $6.0 \times 10^{-3}\text{ m}^3$.

At what rate does the temperature of the water rise? Water has a specific heat capacity of $4200\text{ J kg}^{-1}\text{ K}^{-1}$ and a density of 1000 kg m^{-3} .

- A 0.0040 K s^{-1} B 0.25 K s^{-1} C 4.0 K s^{-1} D 24 K s^{-1}

- 12 Before the invention of the modern refrigerator, ice was manufactured industrially and delivered to households.

One method used ammonia. 75% of the energy required for the ammonia to evaporate came from liquid water at 0°C , turning the water into ice.

If $8.0 \times 10^4\text{ kg}$ of ice was produced in six hours, at what rate did the ammonia need to be evaporated?

The specific latent heat of fusion of water is 330 kJ kg^{-1} .

The specific latent heat of vaporisation of ammonia is 1370 kJ kg^{-1} .

- A 0.67 kg s^{-1} B 1.20 kg s^{-1} C 12.00 kg s^{-1} D 20.00 kg s^{-1}

Space for working

- 13 A ball is released from rest. It falls vertically, hits the ground and bounces back up. Energy losses are negligible.



ground

Which graph shows how the gravitational potential energy of the ball changes during the bounce?

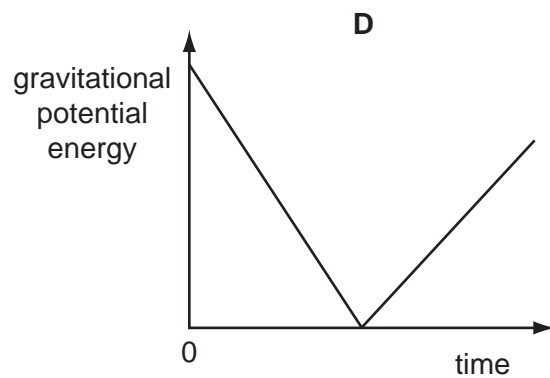
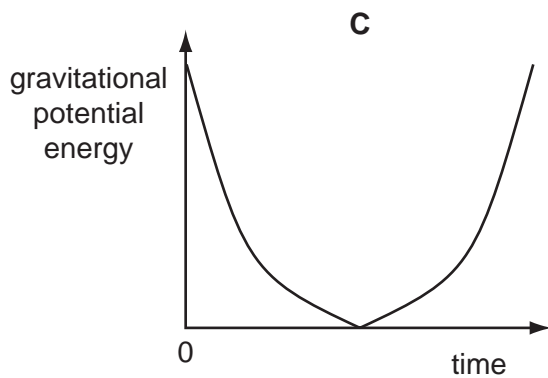
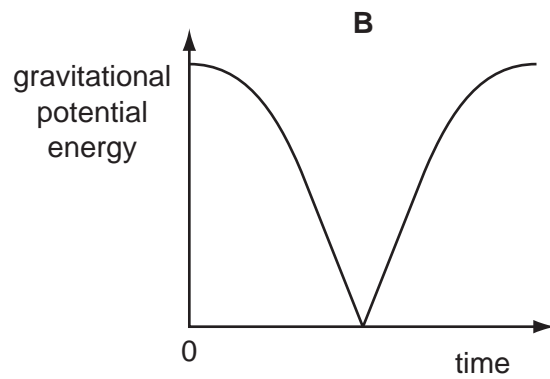
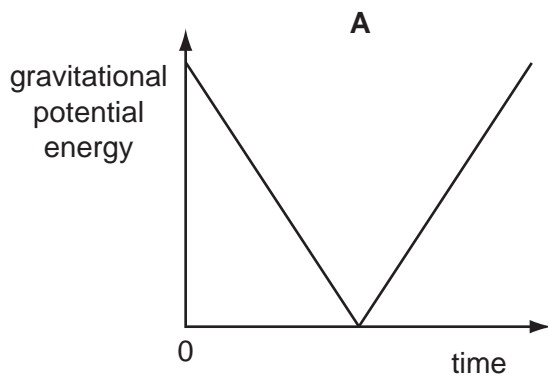

Space for working

14 A force-extension graph for a sample of metal wire is shown.

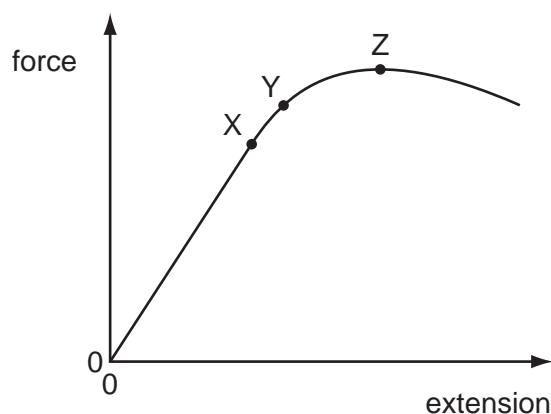

Which row correctly identifies points X, Y and Z?

	point X	point Y	point Z
A	elastic limit	proportional limit	breaking stress
B	elastic limit	proportional limit	yield point
C	proportional limit	elastic limit	breaking stress
D	proportional limit	elastic limit	yield point

15 A guitarist fits two new strings of the same length and material to his guitar. They are tightened to the same tension. One string has four times the radius of the other.

What is the ratio $\frac{\text{stress in the thicker string}}{\text{stress in the thinner string}}$?

- A** 0.0625 **B** 0.25 **C** 4 **D** 16

Space for working

- 16 A load of weight of 4.0 N is attached to the end of an unstretched spring. The load is lowered slowly by hand until it is in equilibrium. The hand is then removed and the load does not oscillate.

The graph shows how the forces exerted by the load vary as it is lowered.

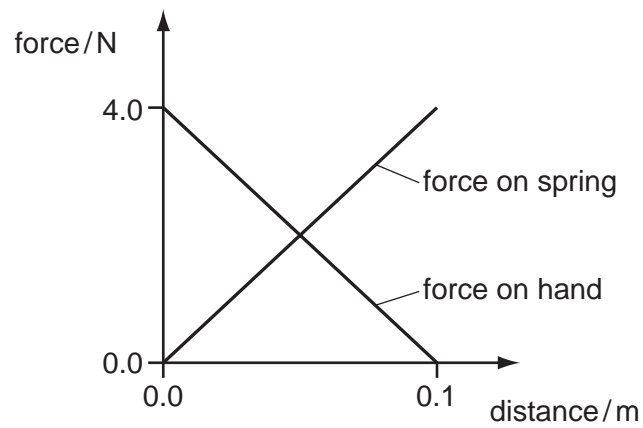

How much energy is stored in the spring?

- A** 0.0J **B** 0.1J **C** 0.2J **D** 0.4J

Space for working

17 An apple is released from rest and falls freely under gravity.

Which graph shows how the kinetic energy (k.e.) of the apple varies with its gravitational potential energy (g.p.e.)?

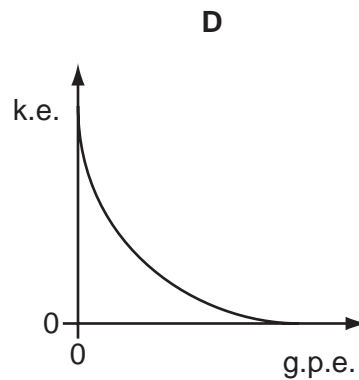
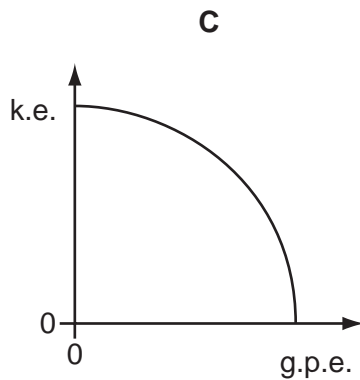
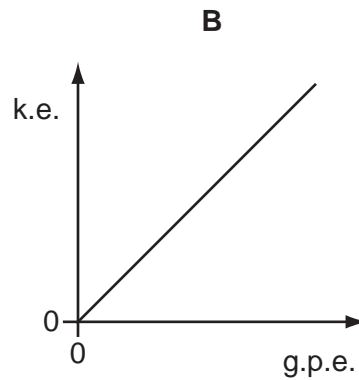
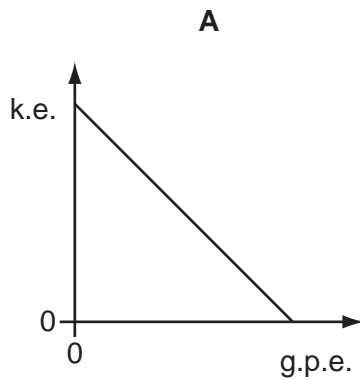

Space for working

- 18 A metal wire of length L and uniform cross-sectional area A has a resistance of $100\ \Omega$. The wire is stretched and L increases by 5%. The volume of the wire remains constant.

What is the resistance of the stretched wire?

- A $95\ \Omega$ B $100\ \Omega$ C $105\ \Omega$ D $110\ \Omega$

- 19 A circuit is connected as shown.

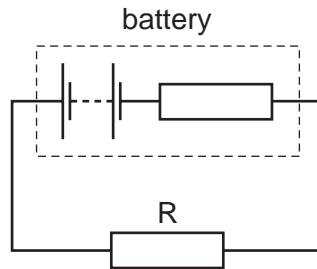

When $100\ \text{C}$ flows around the circuit, $120\ \text{J}$ of electrical energy is dissipated in resistor R and $20\ \text{J}$ in the battery's internal resistance.

What is the e.m.f. of the battery?

- A $0.60\ \text{V}$ B $0.70\ \text{V}$ C $1.2\ \text{V}$ D $1.4\ \text{V}$

Space for working

20 Four identical resistors are connected in a circuit as shown.

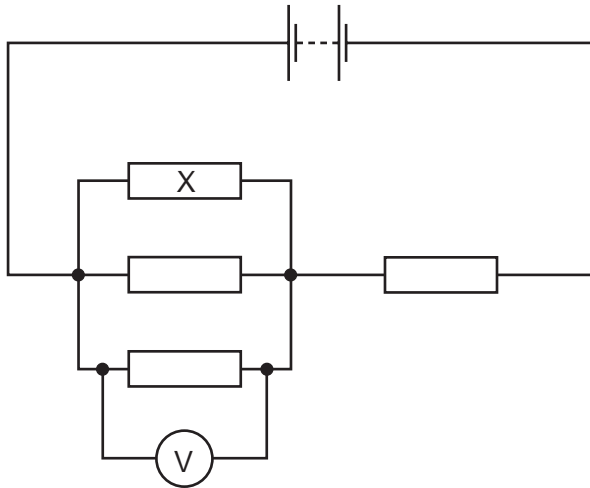

The voltmeter reads 6.0 V. The battery has negligible internal resistance.

What are the correct values for the potential difference across resistor X and the e.m.f. of the battery?

	potential difference across X /V	e.m.f. of battery /V
A	2.0	6.0
B	6.0	6.0
C	6.0	12.0
D	6.0	24.0

Space for working

- 21 The diagram shows how the potential difference (p.d.) across a battery varies with the current that is supplied.

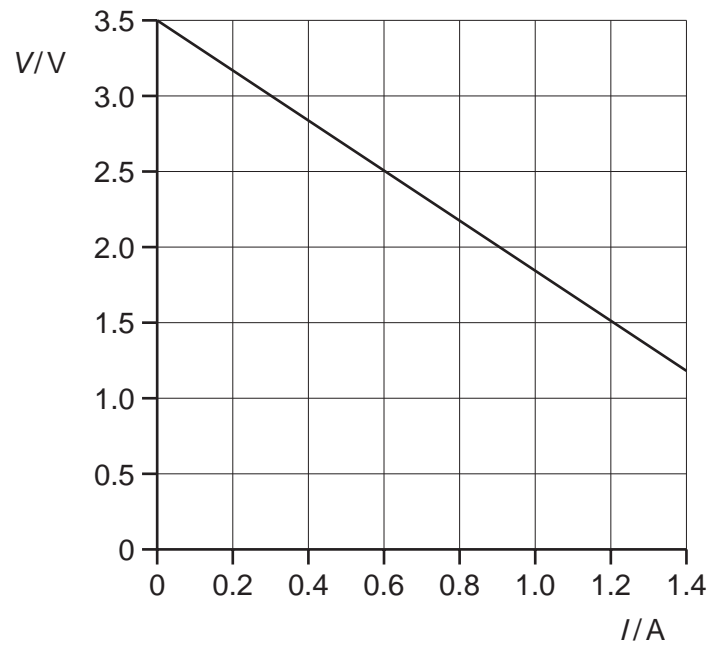

What is the internal resistance of the battery?

- A** $0.60\ \Omega$ **B** $1.20\ \Omega$ **C** $1.70\ \Omega$ **D** $2.30\ \Omega$

Space for working

- 22 Two resistors, each of resistance $100\text{ k}\Omega$, are connected in series with a 6.0 V battery of negligible internal resistance.

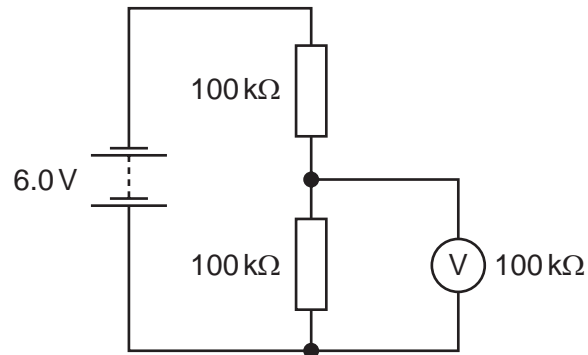

A voltmeter of resistance $100\text{ k}\Omega$ is connected across one of the resistors.

What is the reading on the voltmeter?

- A** 0 V **B** 2.0 V **C** 3.0 V **D** 4.0 V

Space for working

- 23 The resistance of a light-dependent resistor (LDR) is $5\text{ M}\Omega$ in the dark and $1\text{ k}\Omega$ when light shines on it. The LDR is connected in series with a 6 V battery with negligible internal resistance and a $5\text{ k}\Omega$ resistor. The circuit is placed in a dark room and the LDR is then illuminated by a flashing lamp.

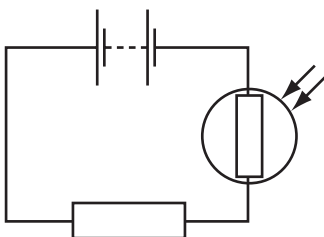

Which diagram shows how the p.d. across the $5\text{ k}\Omega$ resistor varies with time?

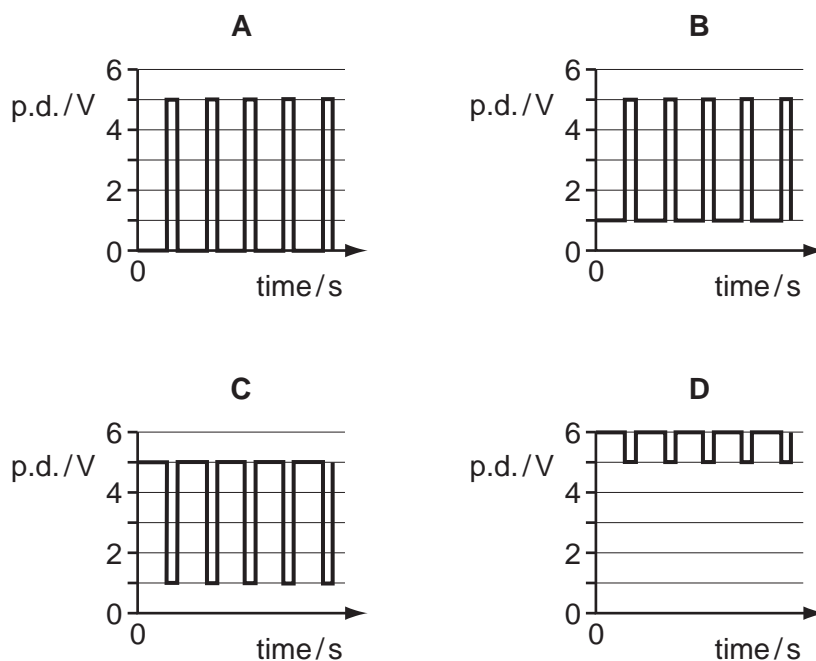

Space for working

- 24 A wave has a frequency of 5 Hz. It travels through a medium at a speed of 8 km s^{-1} .

What is the phase difference, in radians, between two points 2 km apart?

- A 0 B $\frac{\pi}{4}$ C $\frac{\pi}{2}$ D π

- 25 Two radio telescopes separated by a distance d detect parallel waves of wavelength λ from the same distant radio source.

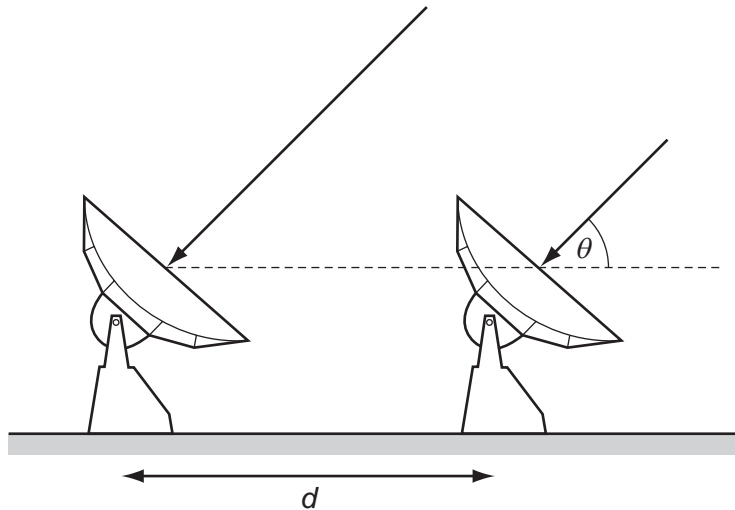

What is the correct expression for the path difference between the waves received at the telescopes?

- A $d \sin \theta$ B $d \cos \theta$ C $\frac{d \sin \theta}{\lambda}$ D $\frac{d \cos \theta}{\lambda}$

Space for working

- 26 The Rayleigh criterion for resolving power is $\theta \approx \lambda / b$. Two sources of radio waves are at a distance of 1×10^{15} m from Earth. The sources are separated by 1×10^{12} m and emit radio waves of wavelength 0.030 m.

What is the estimate for the diameter of a dish of a radio telescope on Earth that will just resolve the two sources?

- A 3×10^{-5} m
B 0.03 m
C 30 m
D 3×10^{-4} m
- 27 A strip of wet cardboard is fixed on the bottom of a microwave oven. The microwave oven is turned on for a short time. When the card is removed a pattern of dry spots is observed on the cardboard. This is because a standing wave is set up inside the oven.

The dry spots are measured and found to occur at 14 mm, 86 mm, 156 mm, 225 mm and 293 mm from the end of the strip.

From this information, what is the frequency of the microwaves?

- A 2.2 GHz B 2.6 GHz C 4.3 GHz D 5.1 GHz
- 28 Laser light is incident upon a double slit and the resulting interference pattern is viewed on a distant screen. A very thin transparent film is then placed in front of one of the slits, such that the light emerging from this slit is now 180° out of phase with the light emerging from the other slit.

What change, if any, will there be in the interference pattern observed on the screen?

- A The interference pattern will be much dimmer.
B The interference pattern will shift slightly.
C There will be no change.
D There will be no interference pattern as there is no longer coherence.

Space for working

29 The diagram shows a square-wave pulse at time $t=0$.

The pulse is travelling to the right at a speed of 4.0 ms^{-1} .

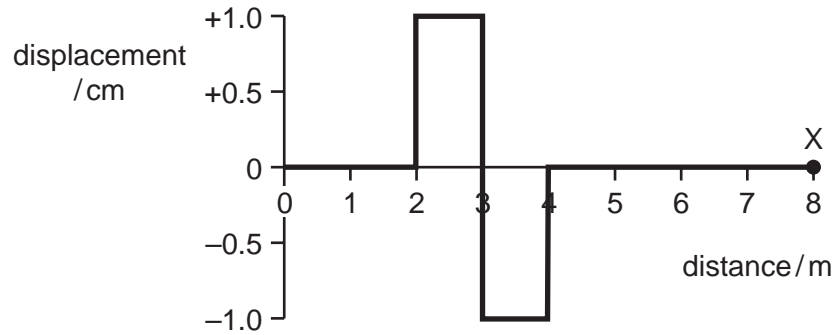

Which graph correctly shows how the displacement of point X will vary over the next 4 seconds?

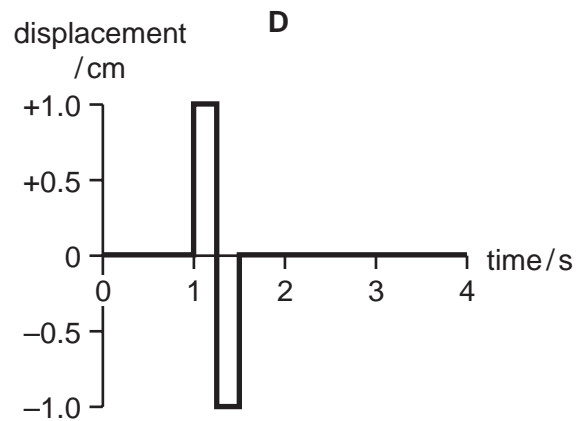
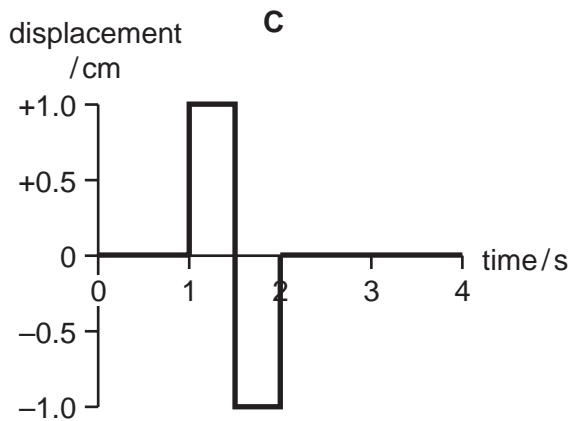
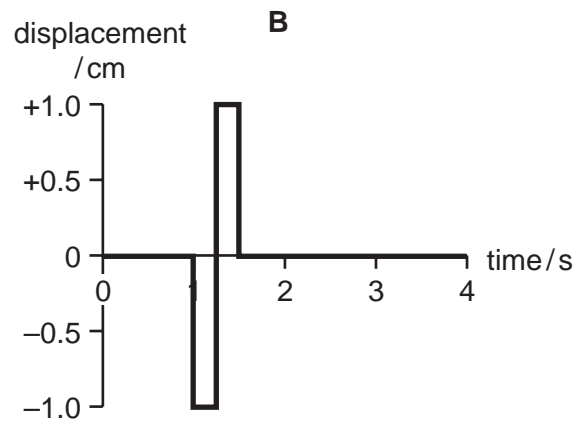
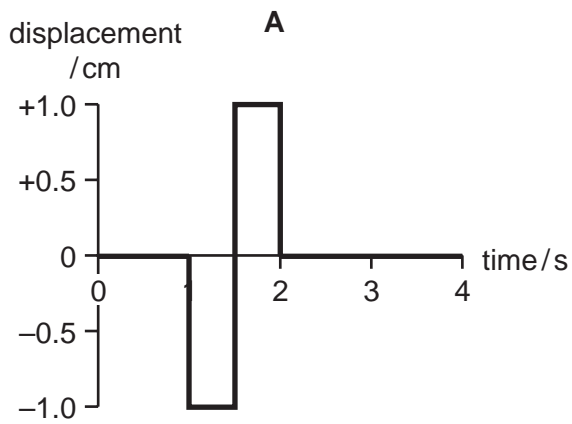

Space for working

30 A lamp is viewed through two polarising filters, X and Y.

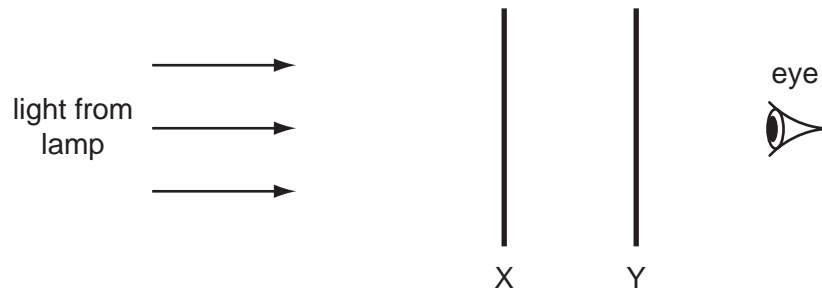

The filters are initially orientated so that the lamp appears with maximum brightness.

Which change in the orientation of the filters will again make the lamp appear with maximum brightness?

	X	Y
A	not turned	turned 90° anticlockwise
B	turned 45° clockwise	turned 45° anticlockwise
C	turned 45° clockwise	turned 90° anticlockwise
D	turned 90° clockwise	turned 90° anticlockwise

Space for working

31 The diagram shows a ray of light passing from air into a glass block.

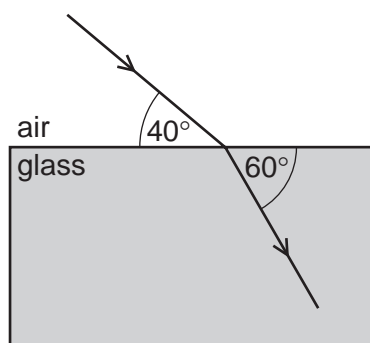

The angle between the ray and the edge of the glass block is 40° in the air and 60° in the glass.

What is the speed of light in the glass block?

- A $2.0 \times 10^8 \text{ m s}^{-1}$
- B $2.2 \times 10^8 \text{ m s}^{-1}$
- C $4.0 \times 10^8 \text{ m s}^{-1}$
- D $4.6 \times 10^8 \text{ m s}^{-1}$

Space for working

32 The graph shows how the amplitude varies with time for two sound waves, X and Y.

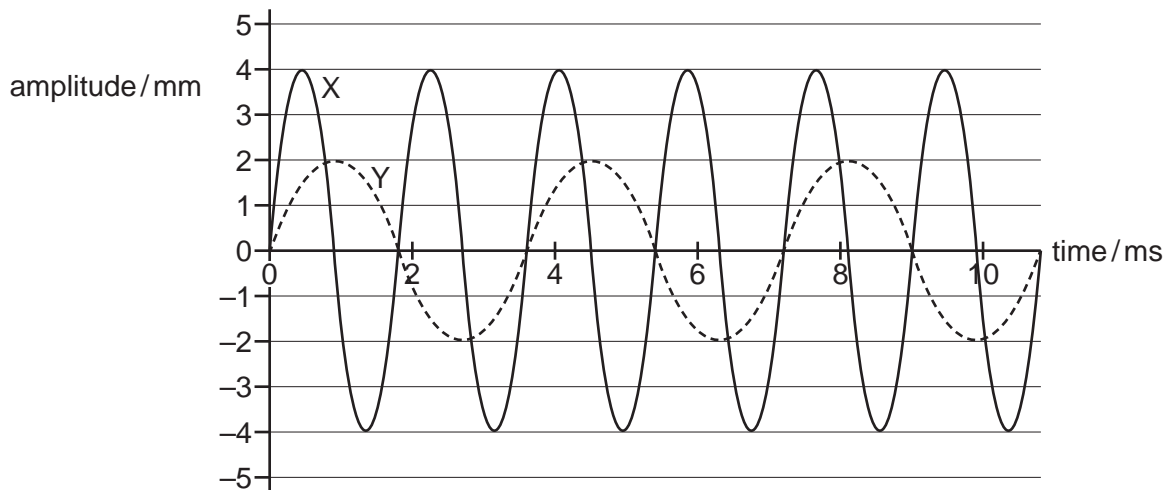

Which row shows the intensity and frequency ratios for X and Y?

	$\frac{\text{intensity of X}}{\text{intensity of Y}}$	$\frac{\text{frequency of X}}{\text{frequency of Y}}$
A	2	$\frac{1}{2}$
B	2	2
C	4	$\frac{1}{2}$
D	4	2

33 Light from distant stars passes through the Earth's atmosphere before it reaches an observer on the surface of the Earth.

Which statement is correct?

- A** Refraction causes the apparent star positions to move around the pole star.
- B** Refraction causes the stars to appear closer to the horizon than they actually are.
- C** Refraction causes the stars to appear higher in the sky than they actually are.
- D** Refraction does not affect the apparent positions of stars in the sky.

Space for working

34 A laser used as a screen pointer emits light of wavelength λ .

What is its power if it emits n photons per second?

A $\frac{n\lambda}{hc}$

B $\frac{hc}{n\lambda}$

C $\frac{\lambda}{nhc}$

D $\frac{nhc}{\lambda}$

35 In a demonstration of the photoelectric effect, it is found that a stopping potential of 1.70 V is required for the photoelectric current to be reduced to zero. The light used in the demonstration has a frequency of 6.0×10^{14} Hz.

What is the work function of the metal?

A 0.79 eV

B 2.28 eV

C 2.49 eV

D 4.19 eV

Space for working

- 36 When a sample of sodium is illuminated with yellow light electrons are ejected from the surface by the photoelectric effect.

Which row describes what happens when the yellow light source is replaced by a blue light source of the same intensity?

	number of electrons emitted per second	maximum kinetic energy of the electrons
A	decreases	decreases
B	decreases	increases
C	stays the same	decreases
D	stays the same	increases

- 37 In an experiment to learn more about the structure of the atom, Geiger and Marsden fired α -particles at a thin sheet of gold foil. They found that most of the α -particles passed through the gold foil with no significant deviation, although a very tiny minority were deflected through large angles, and some were even back-scattered (deflected by more than 90°).

If the experiment is repeated with a foil of a heavier isotope of gold, how would the results be different?

- A** A greater proportion of the α -particles would be deflected through a large angle.
- B** A greater proportion of the α -particles would pass through with no significant deviation.
- C** A greater proportion of the α -particles would be back-scattered.
- D** There would be no significant change.

Space for working

38 A nucleus of radium-226, ${}^{226}_{88}\text{Ra}$, decays by emitting an α -particle.

What is a product of this decay?

- A ${}^{224}_{84}\text{Po}$ B ${}^{222}_{86}\text{Rn}$ C ${}^{227}_{88}\text{Ra}$ D ${}^{226}_{89}\text{Ac}$

39 In a thermal reactor, induced fission occurs when a uranium-235 nucleus absorbs a neutron, splits and produces energy and more neutrons.

Which statement is correct?

- A Control rods are used to slow down the neutrons.
B Slow neutrons are more likely to be absorbed by a uranium-235 nucleus than fast ones.
C The moderator is used to moderate the power output.
D To sustain the nuclear reaction a large number of neutrons is required per fission.

40 A radioactive source consists of a mixture of two isotopes P and Q.

P has a half-life of 60 minutes and Q has a half-life of 30 minutes. The initial activity recorded by a suitable counter is 800 min^{-1} . After 120 minutes the counter registers an activity of 80 min^{-1} .

What was the initial contribution of P to the count rate?

- A 160 min^{-1} B 240 min^{-1} C 270 min^{-1} D 480 min^{-1}

Space for working

BLANK PAGE

Permission to reproduce items where third-party owned material protected by copyright is included has been sought and cleared where possible. Every reasonable effort has been made by the publisher (UCLES) to trace copyright holders, but if any items requiring clearance have unwittingly been included, the publisher will be pleased to make amends at the earliest possible opportunity.

University of Cambridge International Examinations is part of the Cambridge Assessment Group. Cambridge Assessment is the brand name of University of Cambridge Local Examinations Syndicate (UCLES), which is itself a department of the University of Cambridge.