



UNIVERSITY OF CAMBRIDGE INTERNATIONAL EXAMINATIONS
 General Certificate of Education
 Advanced Subsidiary Level and Advanced Level

CANDIDATE
NAME

CENTRE
NUMBER

--	--	--	--	--

CANDIDATE
NUMBER

--	--	--	--



PHYSICS

9702/21

Paper 2 AS Structured Questions

October/November 2011

1 hour

Candidates answer on the Question Paper.

No Additional Materials are required.

READ THESE INSTRUCTIONS FIRST

Write your Centre number, candidate number and name on all the work you hand in.

Write in dark blue or black pen.

You may use a soft pencil for any diagrams, graphs or rough working.

Do not use staples, paper clips, highlighters, glue or correction fluid.

DO NOT WRITE IN ANY BARCODES.

Answer **all** questions.

You may lose marks if you do not show your working or if you do not use appropriate units.

At the end of the examination, fasten all your work securely together.

The number of marks is given in brackets [] at the end of each question or part question.

For Examiner's Use	
1	
2	
3	
4	
5	
6	
7	
Total	

This document consists of **15** printed pages and **1** blank page.



Data

speed of light in free space,	$c = 3.00 \times 10^8 \text{ m s}^{-1}$
permeability of free space,	$\mu_0 = 4\pi \times 10^{-7} \text{ H m}^{-1}$
permittivity of free space,	$\epsilon_0 = 8.85 \times 10^{-12} \text{ F m}^{-1}$
elementary charge,	$e = 1.60 \times 10^{-19} \text{ C}$
the Planck constant,	$h = 6.63 \times 10^{-34} \text{ J s}$
unified atomic mass constant,	$u = 1.66 \times 10^{-27} \text{ kg}$
rest mass of electron,	$m_e = 9.11 \times 10^{-31} \text{ kg}$
rest mass of proton,	$m_p = 1.67 \times 10^{-27} \text{ kg}$
molar gas constant,	$R = 8.31 \text{ J K}^{-1} \text{ mol}^{-1}$
the Avogadro constant,	$N_A = 6.02 \times 10^{23} \text{ mol}^{-1}$
the Boltzmann constant,	$k = 1.38 \times 10^{-23} \text{ J K}^{-1}$
gravitational constant,	$G = 6.67 \times 10^{-11} \text{ N m}^2 \text{ kg}^{-2}$
acceleration of free fall,	$g = 9.81 \text{ m s}^{-2}$

Formulae

uniformly accelerated motion,	$s = ut + \frac{1}{2}at^2$ $v^2 = u^2 + 2as$
work done on/by a gas,	$W = p\Delta V$
gravitational potential,	$\phi = -\frac{Gm}{r}$
hydrostatic pressure,	$p = \rho gh$
pressure of an ideal gas,	$p = \frac{1}{3} \frac{Nm}{V} \langle c^2 \rangle$
simple harmonic motion,	$a = -\omega^2 x$
velocity of particle in s.h.m.,	$v = v_0 \cos \omega t$ $v = \pm \omega \sqrt{(x_0^2 - x^2)}$
electric potential,	$V = \frac{Q}{4\pi\epsilon_0 r}$
capacitors in series,	$1/C = 1/C_1 + 1/C_2 + \dots$
capacitors in parallel,	$C = C_1 + C_2 + \dots$
energy of charged capacitor,	$W = \frac{1}{2} QV$
resistors in series,	$R = R_1 + R_2 + \dots$
resistors in parallel,	$1/R = 1/R_1 + 1/R_2 + \dots$
alternating current/voltage,	$x = x_0 \sin \omega t$
radioactive decay,	$x = x_0 \exp(-\lambda t)$
decay constant,	$\lambda = \frac{0.693}{t_{\frac{1}{2}}}$

Answer **all** the questions in the spaces provided.

1 (a) Define *density*.

.....
..... [1]

(b) Explain how the difference in the densities of solids, liquids and gases may be related to the spacing of their molecules.

.....
.....
.....
..... [2]

(c) A paving slab has a mass of 68 kg and dimensions 50 mm × 600 mm × 900 mm.

(i) Calculate the density, in kg m^{-3} , of the material from which the paving slab is made.

density = kg m^{-3} [2]

(ii) Calculate the maximum pressure a slab could exert on the ground when resting on one of its surfaces.

pressure = Pa [3]

2 (a) Define the *torque* of a couple.

.....
 [2]

(b) A uniform rod of length 1.5 m and weight 2.4 N is shown in Fig. 2.1.

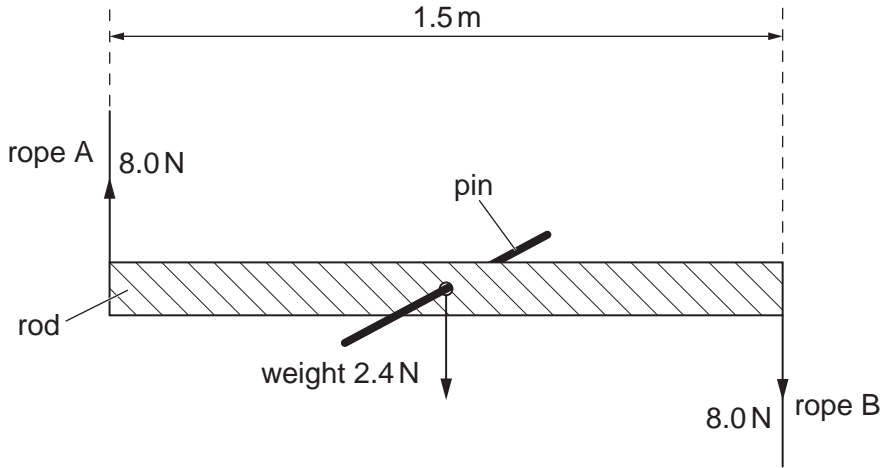

Fig. 2.1

The rod is supported on a pin passing through a hole in its centre. Ropes A and B provide equal and opposite forces of 8.0 N.

(i) Calculate the torque on the rod produced by ropes A and B.

torque = Nm [1]

(ii) Discuss, briefly, whether the rod is in equilibrium.

.....

 [2]

- (c) The rod in (b) is removed from the pin and supported by ropes A and B, as shown in Fig. 2.2.

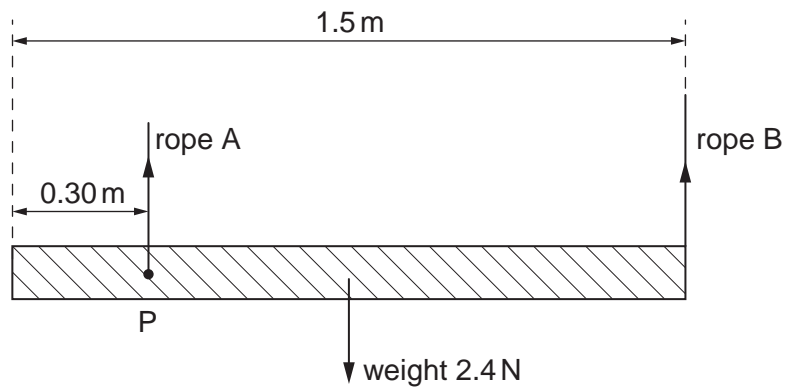

Fig. 2.2

Rope A is now at point P 0.30 m from one end of the rod and rope B is at the other end.

- (i) Calculate the tension in rope B.

tension in B = N [2]

- (ii) Calculate the tension in rope A.

tension in A = N [1]

- 3 A ball is thrown against a vertical wall. The path of the ball is shown in Fig. 3.1.

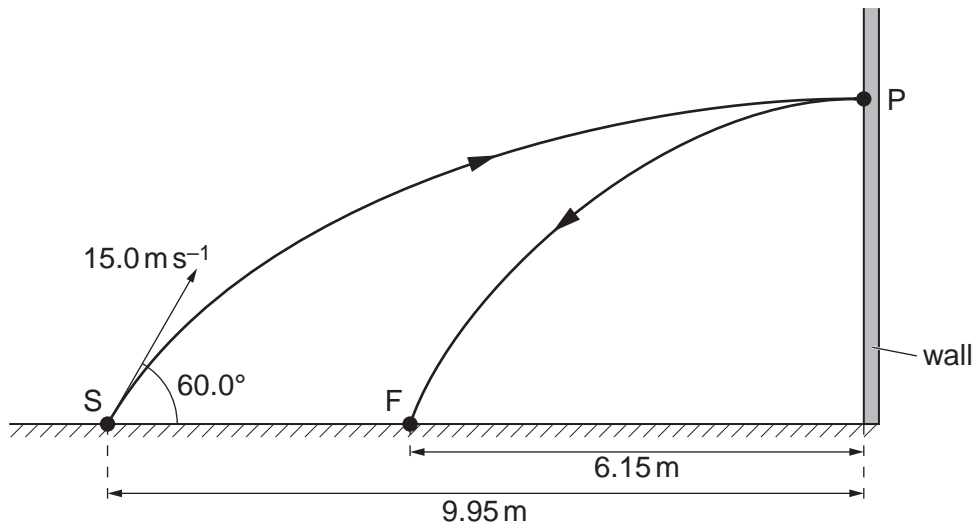

Fig. 3.1 (not to scale)

The ball is thrown from S with an initial velocity of 15.0 ms^{-1} at 60.0° to the horizontal. Assume that air resistance is negligible.

- (a) For the ball at S, calculate

- (i) its horizontal component of velocity,

horizontal component of velocity = ms^{-1} [1]

- (ii) its vertical component of velocity.

vertical component of velocity = ms^{-1} [1]

- (b) The horizontal distance from S to the wall is 9.95 m . The ball hits the wall at P with a velocity that is at right angles to the wall. The ball rebounds to a point F that is 6.15 m from the wall.

Using your answers in (a),

- (i) calculate the vertical height gained by the ball when it travels from S to P,

height = m [1]

(ii) show that the time taken for the ball to travel from S to P is 1.33s,

[1]

(iii) show that the velocity of the ball immediately after rebounding from the wall is about 4.6 m s^{-1} .

[1]

(c) The mass of the ball is $60 \times 10^{-3}\text{ kg}$.

(i) Calculate the change in momentum of the ball as it rebounds from the wall.

change in momentum = N s [2]

(ii) State and explain whether the collision is elastic or inelastic.

.....
.....
..... [1]

- 4 (a) Distinguish between *gravitational potential energy* and *electric potential energy*.

.....

.....

..... [2]

- (b) A body of mass m moves vertically through a distance h near the Earth's surface. Use the defining equation for work done to derive an expression for the gravitational potential energy change of the body.

[2]

- (c) Water flows down a stream from a reservoir and then causes a water wheel to rotate, as shown in Fig. 4.1.

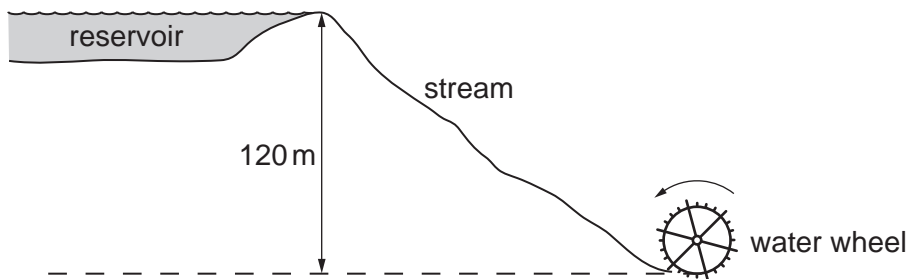

Fig. 4.1

As the water falls through a vertical height of 120 m, gravitational potential energy is converted to different forms of energy, including kinetic energy of the water. At the water wheel, the kinetic energy of the water is only 10% of its gravitational potential energy at the reservoir.

- (i) Show that the speed of the water as it reaches the wheel is 15 m s^{-1} .

[2]

- (ii) The rotating water wheel is used to produce 110kW of electrical power. Calculate the mass of water flowing per second through the wheel, assuming that the production of electric energy from the kinetic energy of the water is 25% efficient.

mass of water per second = kg s^{-1} [3]

5 (a) Define the *ohm*.

..... [1]

(b) Determine the SI base units of **resistivity**.

base units of resistivity = [3]

(c) A cell of e.m.f. 2.0V and negligible internal resistance is connected to a variable resistor R and a metal wire, as shown in Fig. 5.1.

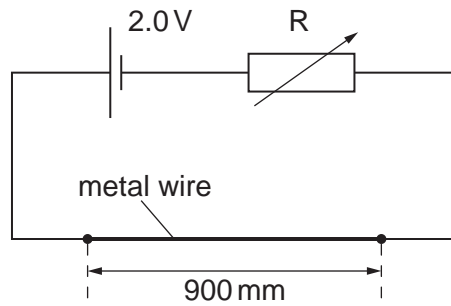

Fig. 5.1

The wire is 900mm long and has an area of cross-section of $1.3 \times 10^{-7} \text{ m}^2$. The resistance of the wire is 3.4Ω .

(i) Calculate the resistivity of the metal wire.

resistivity = [2]

- (ii) The resistance of R may be varied between 0 and $1500\ \Omega$. Calculate the maximum potential difference (p.d.) and minimum p.d. possible across the wire.

maximum p.d. = V

minimum p.d. =V
[2]

- (iii) Calculate the power transformed in the wire when the potential difference across the wire is 2.0V.

power = W [2]

- (d) Resistance R in (c) is now replaced with a different variable resistor Q. State the power transformed in Q, for Q having

- (i) zero resistance,

power = W [1]

- (ii) infinite resistance.

power = W [1]

6 (a) State Hooke's law.

.....
 [1]

(b) The variation with extension x of the force F for a spring A is shown in Fig. 6.1.

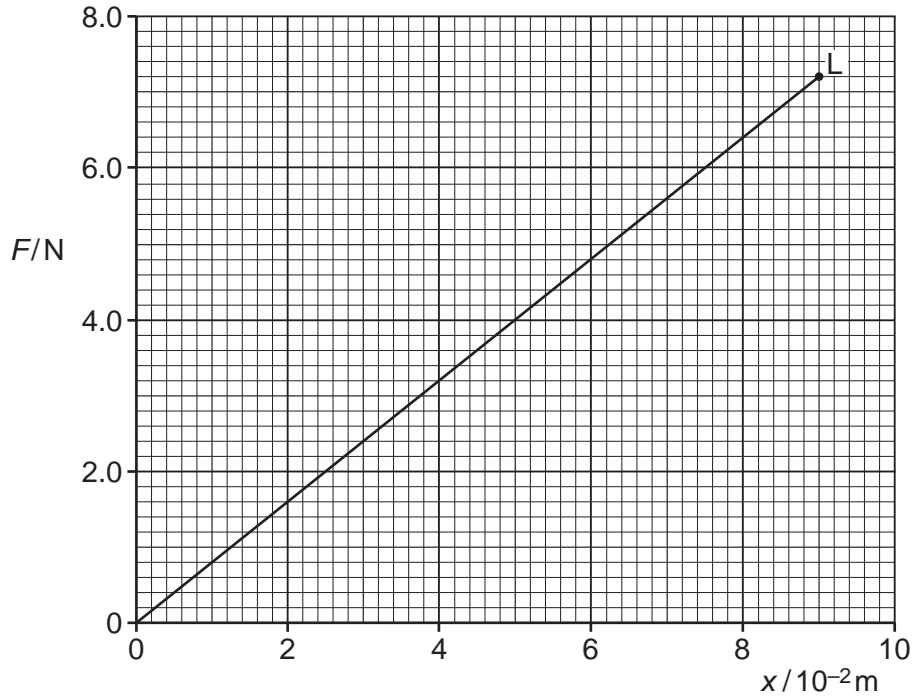

Fig. 6.1

The point L on the graph is the elastic limit of the spring.

(i) Describe the meaning of *elastic limit*.

.....

 [1]

(ii) Calculate the spring constant k_A for spring A.

$k_A = \dots\dots\dots \text{Nm}^{-1}$ [1]

(iii) Calculate the work done in extending the spring with a force of 6.4 N.

work done = J [2]

(c) A second spring B of spring constant $2k_A$ is now joined to spring A, as shown in Fig. 6.2.

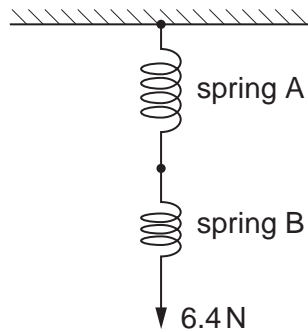

Fig. 6.2

A force of 6.4 N extends the combination of springs.

For the combination of springs, calculate

(i) the total extension,

extension = m [1]

(ii) the spring constant.

spring constant = Nm^{-1} [1]

- 7 (a) Two isotopes of the element uranium are ${}^{235}_{92}\text{U}$ and ${}^{238}_{92}\text{U}$.

Explain the term *isotope*.

.....

 [2]

- (b) (i) In a nuclear reaction, proton number and neutron number are conserved. Other than proton number and neutron number, state a quantity that is conserved in a nuclear reaction.

..... [1]

- (ii) When a nucleus of uranium-235 absorbs a neutron, the following reaction may take place.

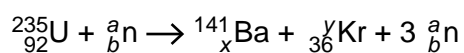

State the values of a , b , x and y .

$a =$

$b =$

$x =$

$y =$

[3]

- (c) When the nucleus of ${}^{238}_{92}\text{U}$ absorbs a neutron, the nucleus decays, emitting an α -particle. State the proton number and nucleon number of the nucleus that is formed as a result of the emission of the α -particle.

proton number =

nucleon number =

[2]

BLANK PAGE

Permission to reproduce items where third-party owned material protected by copyright is included has been sought and cleared where possible. Every reasonable effort has been made by the publisher (UCLES) to trace copyright holders, but if any items requiring clearance have unwittingly been included, the publisher will be pleased to make amends at the earliest possible opportunity.

University of Cambridge International Examinations is part of the Cambridge Assessment Group. Cambridge Assessment is the brand name of University of Cambridge Local Examinations Syndicate (UCLES), which is itself a department of the University of Cambridge.