



UNIVERSITY OF CAMBRIDGE INTERNATIONAL EXAMINATIONS
 General Certificate of Education
 Advanced Subsidiary Level and Advanced Level

CANDIDATE
NAME

CENTRE
NUMBER

--	--	--	--	--

CANDIDATE
NUMBER

--	--	--	--



PHYSICS

9702/21

Paper 2 AS Structured Questions

October/November 2009

1 hour

Candidates answer on the Question Paper.

No Additional Materials are required.

READ THESE INSTRUCTIONS FIRST

Write your Centre number, candidate number and name on all the work you hand in.

Write in dark blue or black pen.

You may use a soft pencil for any diagrams, graphs or rough working.

Do not use staples, paper clips, highlighters, glue or correction fluid.

DO NOT WRITE IN ANY BARCODES.

Answer **all** questions.

You may lose marks if you do not show your working or if you do not use appropriate units.

At the end of the examination, fasten all your work securely together.

The number of marks is given in brackets [] at the end of each question or part question.

For Examiner's Use	
1	
2	
3	
4	
5	
6	
7	
Total	

This document consists of **16** printed pages.



Data

speed of light in free space,	$c = 3.00 \times 10^8 \text{ m s}^{-1}$
permeability of free space,	$\mu_0 = 4\pi \times 10^{-7} \text{ H m}^{-1}$
permittivity of free space,	$\epsilon_0 = 8.85 \times 10^{-12} \text{ F m}^{-1}$
elementary charge,	$e = 1.60 \times 10^{-19} \text{ C}$
the Planck constant,	$h = 6.63 \times 10^{-34} \text{ J s}$
unified atomic mass constant,	$u = 1.66 \times 10^{-27} \text{ kg}$
rest mass of electron,	$m_e = 9.11 \times 10^{-31} \text{ kg}$
rest mass of proton,	$m_p = 1.67 \times 10^{-27} \text{ kg}$
molar gas constant,	$R = 8.31 \text{ J K}^{-1} \text{ mol}^{-1}$
the Avogadro constant,	$N_A = 6.02 \times 10^{23} \text{ mol}^{-1}$
the Boltzmann constant,	$k = 1.38 \times 10^{-23} \text{ J K}^{-1}$
gravitational constant,	$G = 6.67 \times 10^{-11} \text{ N m}^2 \text{ kg}^{-2}$
acceleration of free fall,	$g = 9.81 \text{ m s}^{-2}$

Formulae

uniformly accelerated motion,	$s = ut + \frac{1}{2}at^2$ $v^2 = u^2 + 2as$
work done on/by a gas,	$W = p\Delta V$
gravitational potential,	$\phi = -\frac{Gm}{r}$
hydrostatic pressure,	$p = \rho gh$
pressure of an ideal gas,	$p = \frac{1}{3} \frac{Nm}{V} \langle c^2 \rangle$
simple harmonic motion,	$a = -\omega^2 x$
velocity of particle in s.h.m.,	$v = v_0 \cos \omega t$ $v = \pm \omega \sqrt{(x_0^2 - x^2)}$
electric potential,	$V = \frac{Q}{4\pi\epsilon_0 r}$
capacitors in series,	$1/C = 1/C_1 + 1/C_2 + \dots$
capacitors in parallel,	$C = C_1 + C_2 + \dots$
energy of charged capacitor,	$W = \frac{1}{2} QV$
resistors in series,	$R = R_1 + R_2 + \dots$
resistors in parallel,	$1/R = 1/R_1 + 1/R_2 + \dots$
alternating current/voltage,	$x = x_0 \sin \omega t$
radioactive decay,	$x = x_0 \exp(-\lambda t)$
decay constant,	$\lambda = \frac{0.693}{t_{\frac{1}{2}}}$

Answer **all** the questions in the spaces provided.

- 1 The volume of fuel in the tank of a car is monitored using a meter as illustrated in Fig. 1.1.

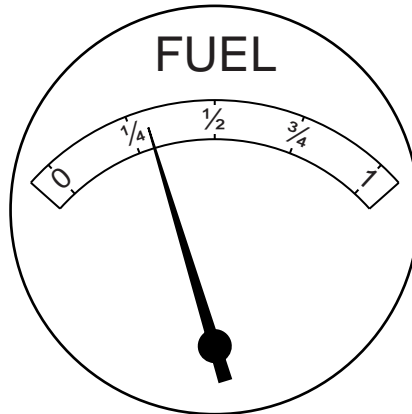

Fig. 1.1

The meter has an analogue scale. The meter reading for different volumes of fuel in the tank is shown in Fig. 1.2.

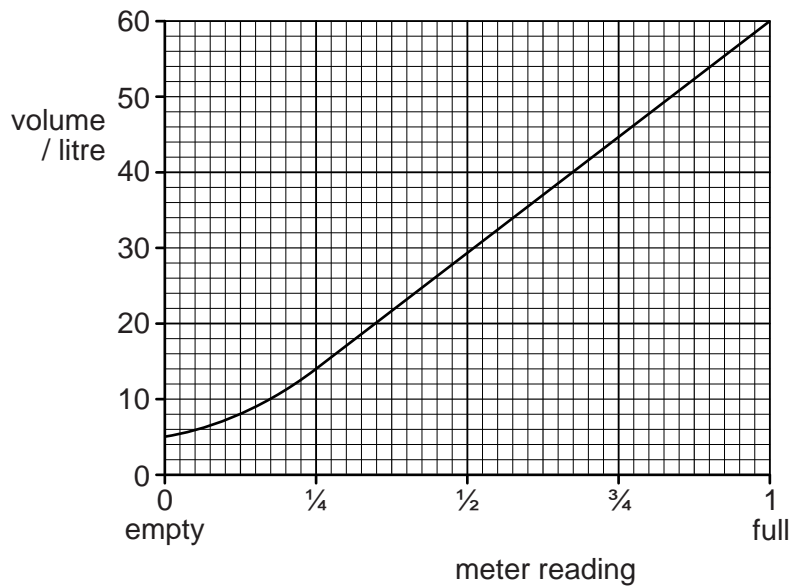

Fig. 1.2

The meter is calibrated in terms of the fraction of the tank that remains filled with fuel.

(a) The car uses 1.0 litre of fuel when travelling 14 km. The car starts a journey with a full tank of fuel.

(i) Calculate the volume of fuel remaining in the tank after a journey of 210 km.

volume = litres [2]

(ii) Use your answer to (i) and Fig. 1.2 to determine the change in the meter reading during the 210 km journey.

from *full* to [1]

(b) There is a systematic error in the meter.

(i) State the feature of Fig. 1.2 that indicates that there is a systematic error.

.....
..... [1]

(ii) Suggest why, for this meter, it is an advantage to have this systematic error.

.....
..... [1]

2 A sky-diver jumps from a high-altitude balloon.

(a) Explain briefly why the acceleration of the sky-diver

(i) decreases with time,

.....

 [2]

(ii) is 9.8 m s^{-2} at the start of the jump.

.....
 [1]

(b) The variation with time t of the vertical speed v of the sky-diver is shown in Fig. 2.1.

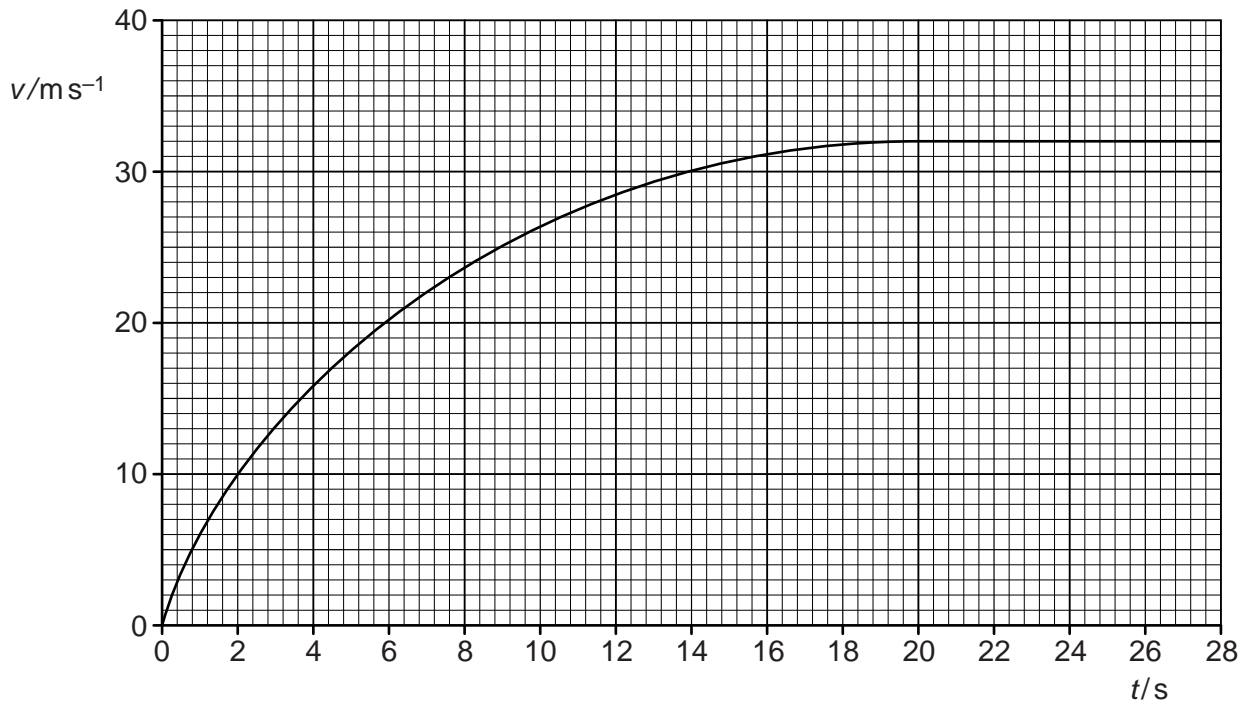

Fig. 2.1

Use Fig. 2.1 to determine the magnitude of the acceleration of the sky-diver at time $t = 6.0$ s.

acceleration = m s^{-2} [3]

(c) The sky-diver and his equipment have a total mass of 90 kg.

(i) Calculate, for the sky-diver and his equipment,

1. the total weight,

weight = N [1]

2. the accelerating force at time $t = 6.0$ s.

force = N [1]

(ii) Use your answers in (i) to determine the total resistive force acting on the sky-diver at time $t = 6.0$ s.

force = N [1]

- 3 A stationary nucleus of mass 220u undergoes radioactive decay to produce a nucleus D of mass 216u and an α -particle of mass 4u , as illustrated in Fig. 3.1.

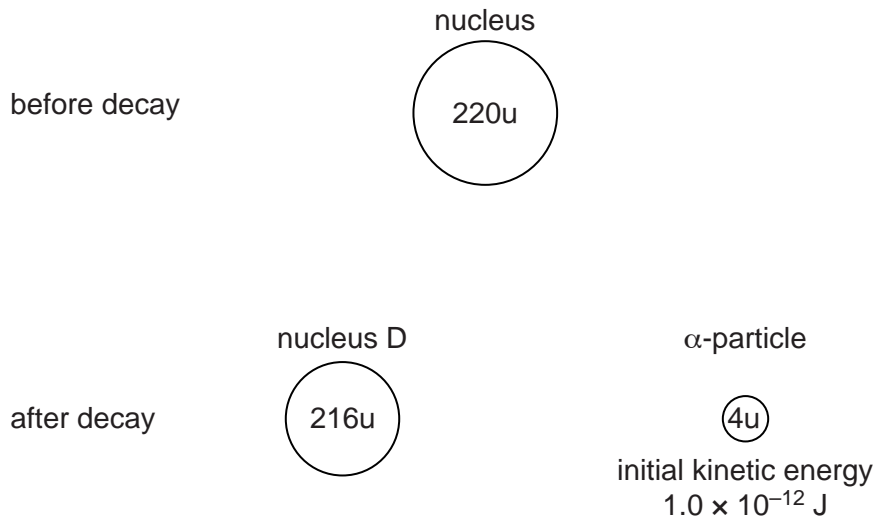

Fig. 3.1

The initial kinetic energy of the α -particle is $1.0 \times 10^{-12} \text{ J}$.

- (a) (i) State the law of conservation of linear momentum.

.....

 [2]

- (ii) Explain why the initial velocities of the nucleus D and the α -particle must be in opposite directions.

.....

 [2]

- (b) (i) Show that the initial speed of the α -particle is $1.7 \times 10^7 \text{ m s}^{-1}$.

[2]

(ii) Calculate the initial speed of nucleus D.

speed = ms^{-1} [2]

(c) The range in air of the emitted α -particle is 4.5 cm.
Calculate the average deceleration of the α -particle as it is stopped by the air.

deceleration = ms^{-2} [2]

- 4 A uniform wire has length L and area of cross-section A .
 The wire is fixed at one end so that it hangs vertically with a load attached to its free end, as shown in Fig. 4.1.

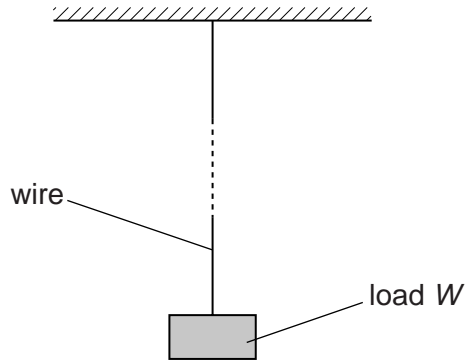

Fig. 4.1

When the load of magnitude W is attached to the wire, it extends by an amount e . The elastic limit of the wire is not exceeded.

The material of the wire has resistivity ρ .

- (a) (i) Explain what is meant by extends *elastically*.

.....

 [2]

- (ii) Write down expressions, in terms of L , A , W , ρ and e for

1. the resistance R of the unstretched wire,

$R = \dots\dots\dots$ [1]

2. the Young modulus E of the wire.

$E = \dots\dots\dots$ [1]

(b) A steel wire has resistance $0.44\ \Omega$. Steel has resistivity $9.2 \times 10^{-8}\ \Omega\text{m}$.

A load of $34\ \text{N}$ hung from the end of the wire causes an extension of $7.7 \times 10^{-4}\ \text{m}$.

Using your answers in (a)(ii), calculate the Young modulus E of steel.

$E = \dots\dots\dots\ \text{Pa}$ [3]

5 (a) State what is meant by a *progressive wave*.

.....

 [2]

(b) The variation with distance x along a progressive wave of a quantity y , at a particular time, is shown in Fig. 5.1.

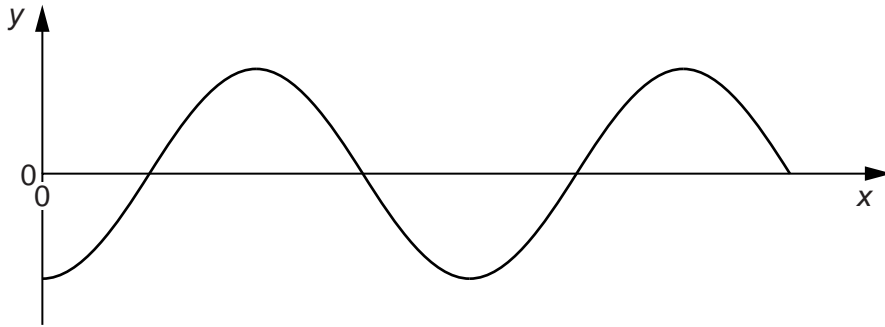

Fig. 5.1

(i) State what the quantity y could represent.

.....
 [1]

(ii) Distinguish between the quantity y for

1. a transverse wave,

.....
 [1]

2. a longitudinal wave.

.....
 [1]

- (c) The wave nature of light may be demonstrated using the phenomena of diffraction and interference.

Outline how diffraction and how interference may be demonstrated using light. In each case, draw a fully labelled diagram of the apparatus that is used and describe what is observed.

diffraction

.....
.....
.....

interference

.....
.....
.....

[6]

- 6 A cell has electromotive force (e.m.f.) E and internal resistance r . It is connected in series with a variable resistor R , as shown in Fig. 6.1.

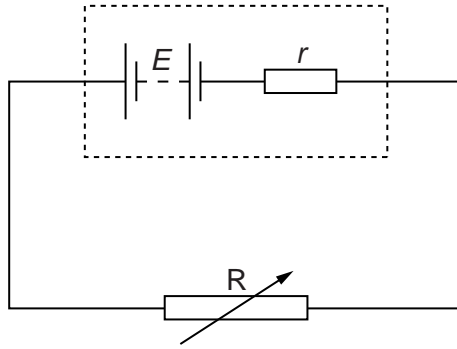

Fig. 6.1

- (a) Define electromotive force (e.m.f.).

.....

.....

..... [2]

- (b) The variable resistor R has resistance X . Show that

$$\frac{\text{power dissipated in resistor } R}{\text{power produced in cell}} = \frac{X}{X + r}.$$

[3]

(c) The variation with resistance X of the power P_R dissipated in R is shown in Fig. 6.2.

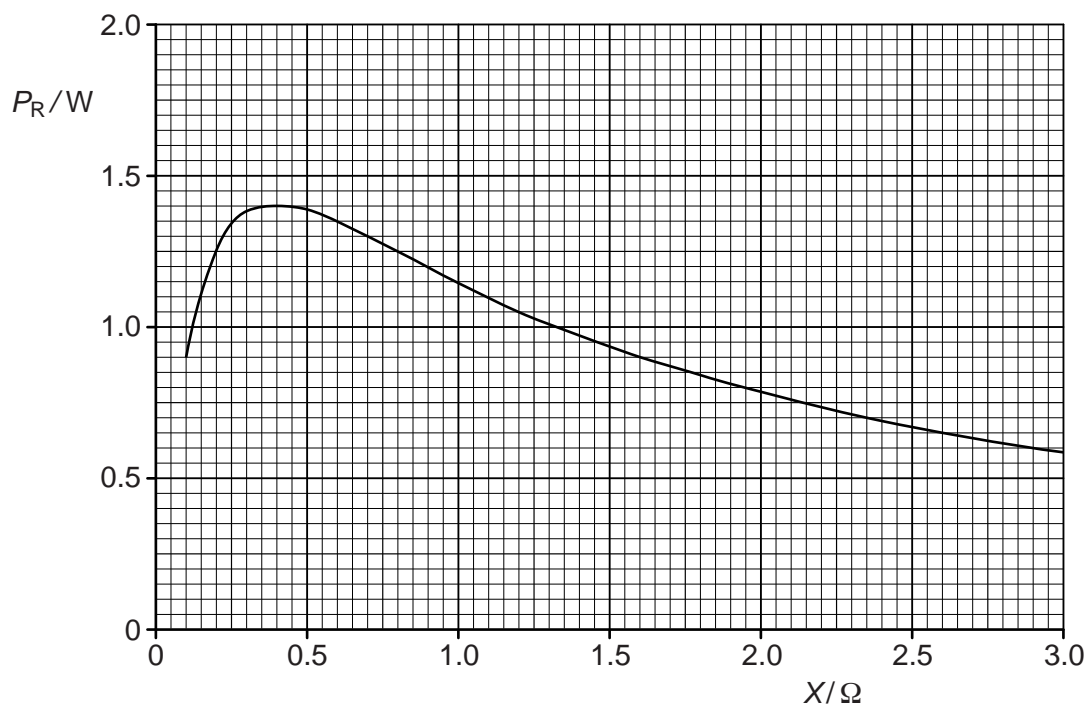

Fig. 6.2

(i) Use Fig. 6.2 to state, for maximum power dissipation in resistor R , the magnitude of this power and the resistance of R .

maximum power = W

resistance = Ω
[2]

(ii) The cell has e.m.f. 1.5V.
Use your answers in (i) to calculate the internal resistance of the cell.

internal resistance = Ω [3]

(d) In Fig. 6.2, it can be seen that, for larger values of X , the power dissipation decreases. Use the relationship in (b) to suggest one advantage, despite the lower power output, of using the cell in a circuit where the resistance X is larger than the internal resistance of the cell.

.....
..... [1]

7 An α -particle A approaches and passes by a stationary gold nucleus N. The path is illustrated in Fig. 7.1.

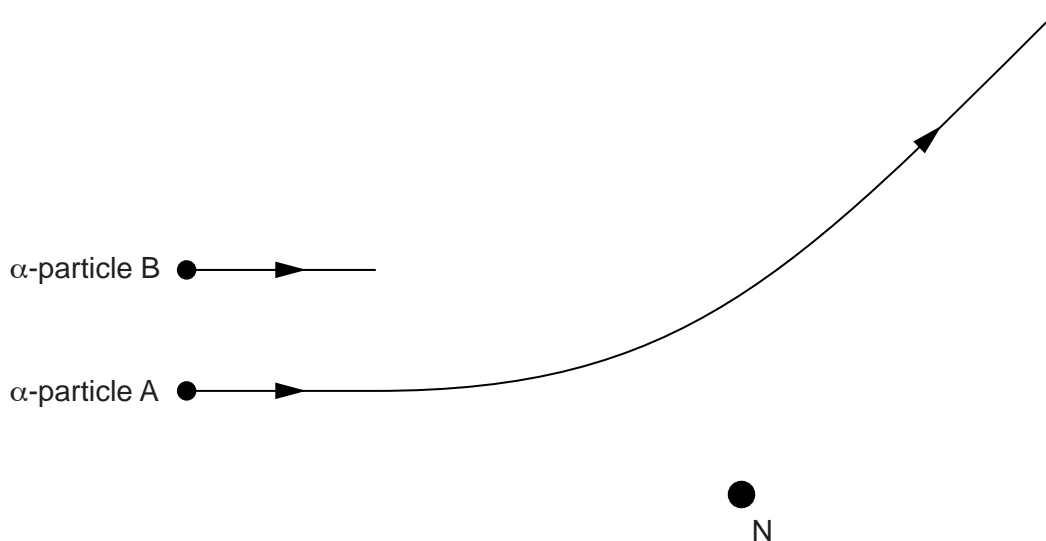

Fig. 7.1

- (a) On Fig. 7.1, mark the angle of deviation D of this α -particle as a result of passing the nucleus N. [1]
- (b) A second α -particle B has the same initial direction and energy as α -particle A. On Fig. 7.1, complete the path of α -particle B as it approaches and passes by the nucleus N. [2]
- (c) State what can be inferred about atoms from the observation that very few α -particles experience large deviations. [2]

.....

 [2]

- (d) The nucleus N could be one of several different isotopes of gold. Suggest, with an explanation, whether different isotopes of gold would give rise to different deviations of a particular α -particle. [2]

.....

 [2]

Permission to reproduce items where third-party owned material protected by copyright is included has been sought and cleared where possible. Every reasonable effort has been made by the publisher (UCLES) to trace copyright holders, but if any items requiring clearance have unwittingly been included, the publisher will be pleased to make amends at the earliest possible opportunity.

University of Cambridge International Examinations is part of the Cambridge Assessment Group. Cambridge Assessment is the brand name of University of Cambridge Local Examinations Syndicate (UCLES), which is itself a department of the University of Cambridge.