

UNIVERSITY OF CAMBRIDGE INTERNATIONAL EXAMINATIONS
General Certificate of Education
Advanced Subsidiary Level and
Advanced Level



PHYSICS
Paper 2

9702/02

October/November 2004

1 hour

Candidates answer on the Question Paper.
No Additional Materials are required.

Candidate
Name

| |
|--|
| |
|--|

Centre
Number

| | | | | |
|--|--|--|--|--|
| | | | | |
|--|--|--|--|--|

Candidate
Number

| | | | |
|--|--|--|--|
| | | | |
|--|--|--|--|

READ THESE INSTRUCTIONS FIRST

Write your Centre number, candidate number and name on all the work you hand in.
Write in dark blue or black pen in the spaces provided on the Question Paper.
You may use a soft pencil for any diagrams, graphs or rough working.
Do not use staples, paper clips, highlighters, glue or correction fluid.

Answer **all** questions.

The number of marks is given in brackets [] at the end of each question or part question.
You may lose marks if you do not show your working or if you do not use appropriate units.

DO NOT WRITE IN THE BARCODE.

DO NOT WRITE IN THE GREY AREAS BETWEEN THE PAGES.

If you have been given a label, look at the details. If any details are incorrect or missing, please fill in your correct details in the space given at the top of this page.

Stick your personal label here, if provided.

| For Examiner's Use | |
|--------------------|--|
| 1 | |
| 2 | |
| 3 | |
| 4 | |
| 5 | |
| 6 | |
| 7 | |
| Total | |

This document consists of **15** printed pages and **1** blank page.



Data

| | |
|-------------------------------|--|
| speed of light in free space, | $c = 3.00 \times 10^8 \text{ m s}^{-1}$ |
| permeability of free space, | $\mu_0 = 4\pi \times 10^{-7} \text{ H m}^{-1}$ |
| permittivity of free space, | $\epsilon_0 = 8.85 \times 10^{-12} \text{ F m}^{-1}$ |
| elementary charge, | $e = 1.60 \times 10^{-19} \text{ C}$ |
| the Planck constant, | $h = 6.63 \times 10^{-34} \text{ J s}$ |
| unified atomic mass constant, | $u = 1.66 \times 10^{-27} \text{ kg}$ |
| rest mass of electron, | $m_e = 9.11 \times 10^{-31} \text{ kg}$ |
| rest mass of proton, | $m_p = 1.67 \times 10^{-27} \text{ kg}$ |
| molar gas constant, | $R = 8.31 \text{ J K}^{-1} \text{ mol}^{-1}$ |
| the Avogadro constant, | $N_A = 6.02 \times 10^{23} \text{ mol}^{-1}$ |
| the Boltzmann constant, | $k = 1.38 \times 10^{-23} \text{ J K}^{-1}$ |
| gravitational constant, | $G = 6.67 \times 10^{-11} \text{ N m}^2 \text{ kg}^{-2}$ |
| acceleration of free fall, | $g = 9.81 \text{ m s}^{-2}$ |

Formulae

| | |
|---|--|
| uniformly accelerated motion, | $s = ut + \frac{1}{2}at^2$ $v^2 = u^2 + 2as$ |
| work done on/by a gas, | $W = p\Delta V$ |
| gravitational potential, | $\phi = -\frac{Gm}{r}$ |
| simple harmonic motion, | $a = -\omega^2x$ |
| velocity of particle in s.h.m., | $v = v_0 \cos \omega t$ $v = \pm \omega \sqrt{(x_0^2 - x^2)}$ |
| resistors in series, | $R = R_1 + R_2 + \dots$ |
| resistors in parallel, | $1/R = 1/R_1 + 1/R_2 + \dots$ |
| electric potential, | $V = \frac{Q}{4\pi\epsilon_0 r}$ |
| capacitors in series, | $1/C = 1/C_1 + 1/C_2 + \dots$ |
| capacitors in parallel, | $C = C_1 + C_2 + \dots$ |
| energy of charged capacitor, | $W = \frac{1}{2}QV$ |
| alternating current/voltage, | $x = x_0 \sin \omega t$ |
| hydrostatic pressure, | $p = \rho gh$ |
| pressure of an ideal gas, | $p = \frac{1}{3} \frac{Nm}{V} \langle c^2 \rangle$ |
| radioactive decay, | $x = x_0 \exp(-\lambda t)$ |
| decay constant, | $\lambda = \frac{0.693}{t_{\frac{1}{2}}}$ |
| critical density of matter in the Universe, | $\rho_0 = \frac{3H_0^2}{8\pi G}$ |
| equation of continuity, | $Av = \text{constant}$ |
| Bernoulli equation (simplified), | $p_1 + \frac{1}{2}\rho v_1^2 = p_2 + \frac{1}{2}\rho v_2^2$ |
| Stokes' law, | $F = Ar\eta v$ |
| Reynolds' number, | $R_e = \frac{\rho v r}{\eta}$ |
| drag force in turbulent flow, | $F = Br^2\rho v^2$ |

Answer **all** the questions in the spaces provided.

1 A student takes readings to measure the mean diameter of a wire using a micrometer screw gauge.

(a) Make suggestions, one in each case, that the student may adopt in order to

(i) reduce a systematic error in the readings,

.....

(ii) allow for a wire of varying diameter along its length,

.....

(iii) allow for a non-circular cross-section of the wire.

.....

[3]

(b) The mean diameter of the wire is found to be 0.50 ± 0.02 mm. Calculate the percentage uncertainty in

(i) the diameter,

uncertainty = %

(ii) the area of cross-section of the wire.

uncertainty = %
 [2]

2 The spectrum of electromagnetic waves is divided into a number of regions such as radio waves, visible light and gamma radiation.

(a) State three distinct features of waves that are common to all regions of the electromagnetic spectrum.

1.

2.

3. [3]

(b) A typical wavelength of visible light is 495 nm. Calculate the number of wavelengths of this light in a wave of length 1.00 m.

number = [2]

(c) State a typical wavelength for

(i) X-rays,

wavelength = m

(ii) infra-red radiation.

wavelength = m
[2]

- 3 A girl stands at the top of a cliff and throws a ball vertically upwards with a speed of 12 m s^{-1} , as illustrated in Fig. 3.1.

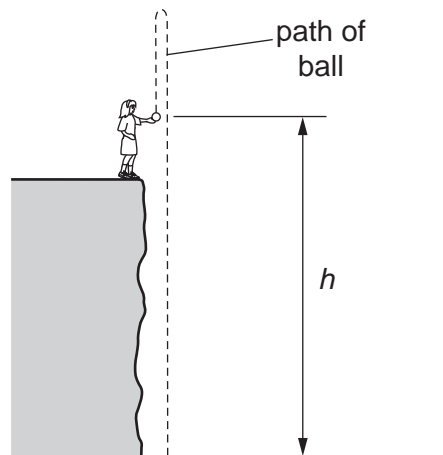

Fig. 3.1

At the time that the girl throws the ball, her hand is a height h above the horizontal ground at the base of the cliff.

The variation with time t of the speed v of the ball is shown in Fig. 3.2.

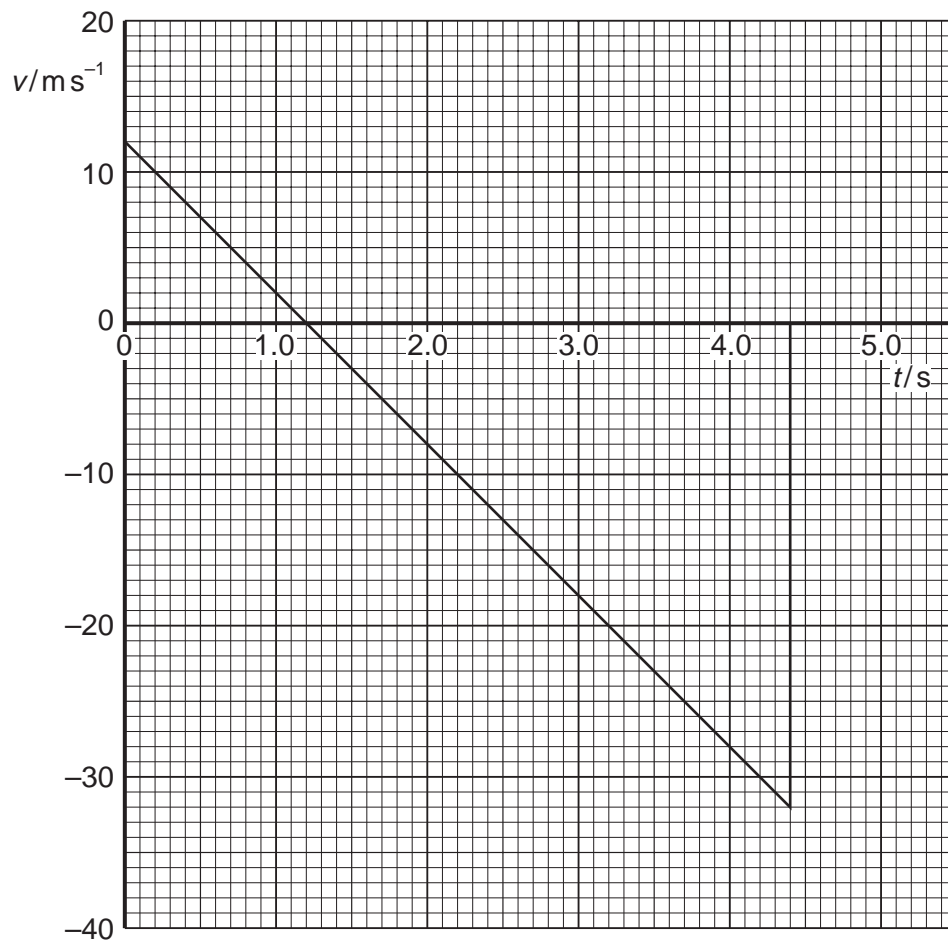

Fig. 3.2

Speeds in the upward direction are shown as being positive. Speeds in the downward direction are negative.

- (a) State the feature of Fig. 3.2 that shows that the acceleration is constant.

..... [1]

- (b) Use Fig. 3.2 to determine the time at which the ball

- (i) reaches maximum height,

time = s

- (ii) hits the ground at the base of the cliff.

time = s
[2]

- (c) Determine the maximum height above the base of the cliff to which the ball rises.

height = m [3]

- (d) The ball has mass 250 g. Calculate the magnitude of the change in momentum of the ball between the time that it leaves the girl's hand to time $t = 4.0$ s.

change = N s [3]

(e) (i) State the principle of conservation of momentum.

.....
.....
..... [2]

(ii) Comment on your answer to (d) by reference to this principle.

.....
.....
.....
..... [3]

- 4 A string is stretched between two fixed points. It is plucked at its centre and the string vibrates, forming a stationary wave as illustrated in Fig. 4.1.

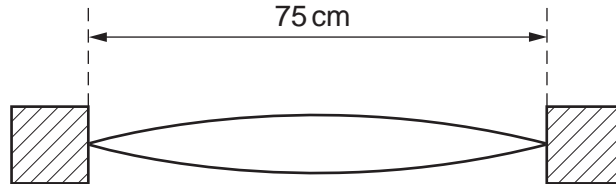

Fig. 4.1

The length of the string is 75 cm.

- (a) State the wavelength of the wave.

wavelength = m [1]

- (b) The frequency of vibration of the string is 360 Hz. Calculate the speed of the wave on the string.

speed = m s^{-1} [2]

- (c) By reference to the formation of the stationary wave on the string, explain what is meant by the speed calculated in (b).

.....

 [3]

- 5 (a) A metal wire has an unstretched length L and area of cross-section A . When the wire supports a load F , the wire extends by an amount ΔL . The wire obeys Hooke's law.

Write down expressions, in terms of L , A , F and ΔL , for

- (i) the applied stress,

.....

- (ii) the tensile strain in the wire,

.....

- (iii) the Young modulus of the material of the wire.

.....

[3]

- (b) A steel wire of uniform cross-sectional area $7.9 \times 10^{-7} \text{ m}^2$ is heated to a temperature of 650 K. It is then clamped between two rigid supports, as shown in Fig. 5.1.

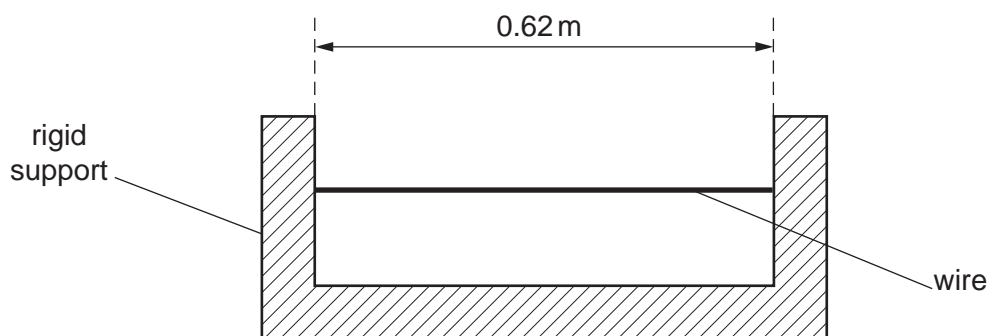

Fig. 5.1

The wire is straight but not under tension and the length between the supports is 0.62 m. The wire is then allowed to cool to 300 K.

When the wire is allowed to contract freely, a 1.00 m length of the wire decreases in length by 0.012 mm for every 1 K decrease in temperature.

- (i) Show that the change in length of the wire, if it were allowed to contract as it cools from 650 K to 300 K, would be 2.6 mm.

[2]

- (ii) The Young modulus of steel is 2.0×10^{11} Pa. Calculate the tension in the wire at 300 K, assuming that the wire obeys Hooke's law.

tension = N [2]

- (iii) The ultimate tensile stress of steel is 250 MPa. Use this information and your answer in (ii) to suggest whether the wire will, in practice, break as it cools.

.....
..... [3]

- 6 Fig. 6.1 shows the variation with applied potential difference V of the current I in an electrical component C.

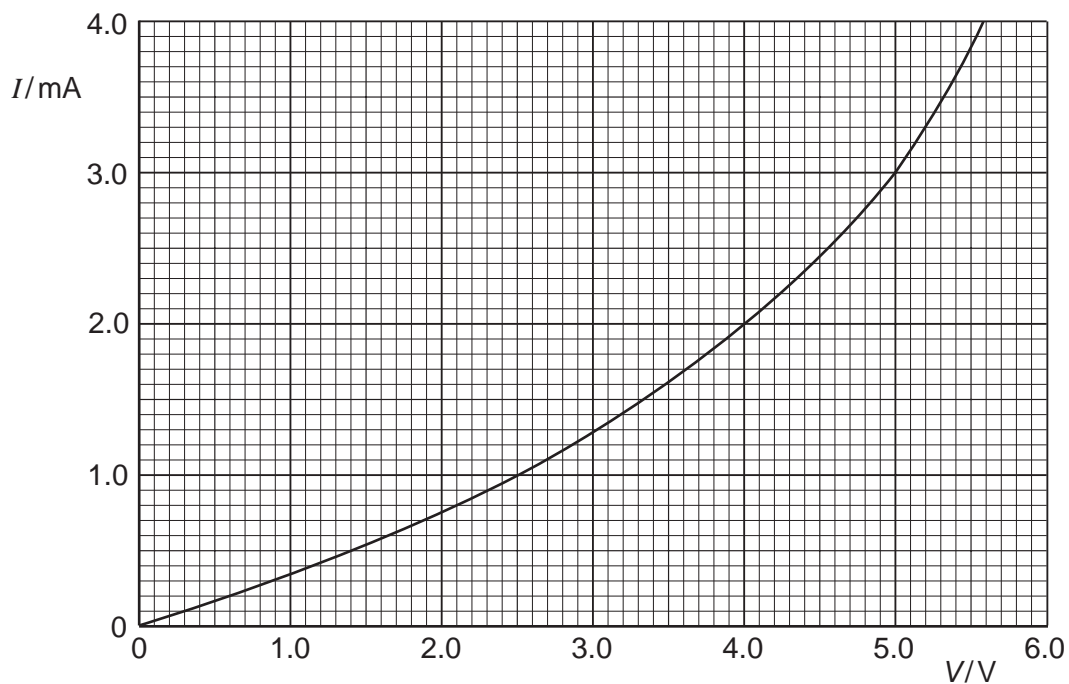

Fig. 6.1

- (a) (i) State, with a reason, whether the resistance of component C increases or decreases with increasing potential difference.

.....
 [2]

- (ii) Determine the resistance of component C at a potential difference of 4.0 V.

resistance = Ω [2]

- (b) Component C is connected in parallel with a resistor R of resistance $1500\ \Omega$ and a battery of e.m.f. E and negligible internal resistance, as shown in Fig. 6.2.

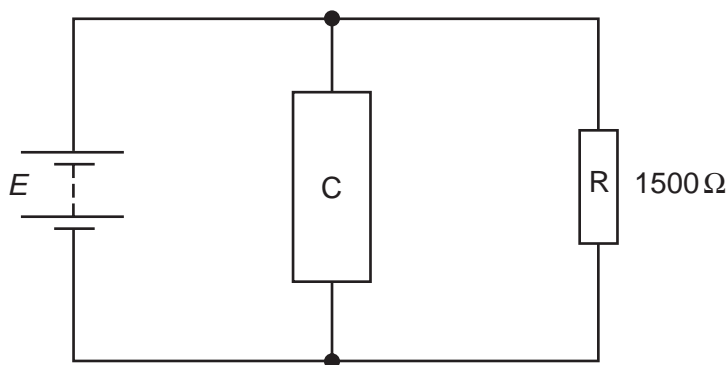

Fig. 6.2

- (i) On Fig. 6.1, draw a line to show the variation with potential difference V of the current I in resistor R. [2]
- (ii) Hence, or otherwise, use Fig. 6.1 to determine the current in the battery for an e.m.f. of 2.0 V.

current = A [2]

- (c) The resistor R of resistance $1500\ \Omega$ and the component C are now connected in series across a supply of e.m.f. 7.0 V and negligible internal resistance.

Using information from Fig. 6.1, state and explain which component, R or C, will dissipate thermal energy at a greater rate.

.....

.....

.....

..... [3]

7 The α -particle scattering experiment provided evidence for the existence of a nuclear atom.

(a) State what could be deduced from the fact that

(i) most α -particles were deviated through angles of less than 10° ,

.....
.....
..... [2]

(ii) a very small proportion of the α -particles was deviated through angles greater than 90° .

.....
.....
..... [2]

- (b) Fig. 7.1 shows the path AB of an α -particle as it approaches and passes by a stationary gold nucleus.

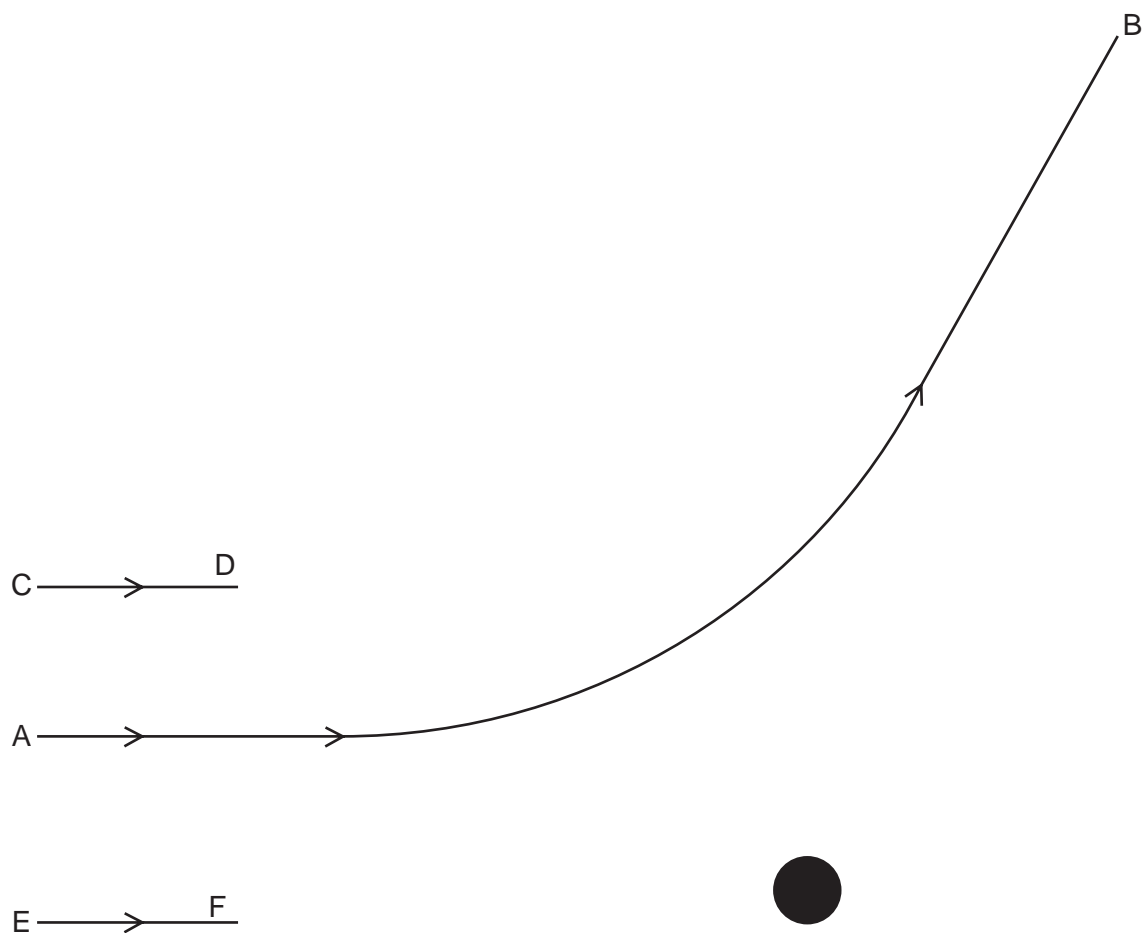

Fig. 7.1

On Fig. 7.1, draw lines (one in each case) to complete the paths of the α -particles passing by the gold nucleus when the initial direction of approach is

- (i) along line CD,
- (ii) along line EF.

[3]

Every reasonable effort has been made to trace all copyright holders where the publishers (i.e. UCLES) are aware that third-party material has been reproduced. The publishers would be pleased to hear from anyone whose rights they have unwittingly infringed.

University of Cambridge International Examinations is part of the University of Cambridge Local Examinations Syndicate (UCLES), which is itself a department of the University of Cambridge.