



UNIVERSITY OF CAMBRIDGE INTERNATIONAL EXAMINATIONS
 General Certificate of Education
 Advanced Subsidiary Level and Advanced Level

CANDIDATE
 NAME

CENTRE
 NUMBER

--	--	--	--	--	--

CANDIDATE
 NUMBER

--	--	--	--	--



PHYSICS

9702/21

Paper 2 AS Structured Questions

May/June 2011

1 hour

Candidates answer on the Question Paper.

No Additional Materials are required.

READ THESE INSTRUCTIONS FIRST

Write your Centre number, candidate number and name on all the work you hand in.

Write in dark blue or black pen.

You may use a soft pencil for any diagrams, graphs or rough working.

Do not use staples, paper clips, highlighters, glue or correction fluid.

DO NOT WRITE IN ANY BARCODES.

Answer **all** questions.

You may lose marks if you do not show your working or if you do not use appropriate units.

At the end of the examination, fasten all your work securely together.

The number of marks is given in brackets [] at the end of each question or part question.

For Examiner's Use	
1	
2	
3	
4	
5	
6	
7	
Total	

This document consists of **16** printed pages.



Data

speed of light in free space,	$c = 3.00 \times 10^8 \text{ m s}^{-1}$
permeability of free space,	$\mu_0 = 4\pi \times 10^{-7} \text{ H m}^{-1}$
permittivity of free space,	$\epsilon_0 = 8.85 \times 10^{-12} \text{ F m}^{-1}$
elementary charge,	$e = 1.60 \times 10^{-19} \text{ C}$
the Planck constant,	$h = 6.63 \times 10^{-34} \text{ J s}$
unified atomic mass constant,	$u = 1.66 \times 10^{-27} \text{ kg}$
rest mass of electron,	$m_e = 9.11 \times 10^{-31} \text{ kg}$
rest mass of proton,	$m_p = 1.67 \times 10^{-27} \text{ kg}$
molar gas constant,	$R = 8.31 \text{ J K}^{-1} \text{ mol}^{-1}$
the Avogadro constant,	$N_A = 6.02 \times 10^{23} \text{ mol}^{-1}$
the Boltzmann constant,	$k = 1.38 \times 10^{-23} \text{ J K}^{-1}$
gravitational constant,	$G = 6.67 \times 10^{-11} \text{ N m}^2 \text{ kg}^{-2}$
acceleration of free fall,	$g = 9.81 \text{ m s}^{-2}$

Formulae

uniformly accelerated motion,	$s = ut + \frac{1}{2}at^2$ $v^2 = u^2 + 2as$
work done on/by a gas,	$W = p\Delta V$
gravitational potential,	$\phi = -\frac{Gm}{r}$
hydrostatic pressure,	$p = \rho gh$
pressure of an ideal gas,	$p = \frac{1}{3} \frac{Nm}{V} \langle c^2 \rangle$
simple harmonic motion,	$a = -\omega^2 x$
velocity of particle in s.h.m.,	$v = v_0 \cos \omega t$ $v = \pm \omega \sqrt{(x_0^2 - x^2)}$
electric potential,	$V = \frac{Q}{4\pi\epsilon_0 r}$
capacitors in series,	$1/C = 1/C_1 + 1/C_2 + \dots$
capacitors in parallel,	$C = C_1 + C_2 + \dots$
energy of charged capacitor,	$W = \frac{1}{2} QV$
resistors in series,	$R = R_1 + R_2 + \dots$
resistors in parallel,	$1/R = 1/R_1 + 1/R_2 + \dots$
alternating current/voltage,	$x = x_0 \sin \omega t$
radioactive decay,	$x = x_0 \exp(-\lambda t)$
decay constant,	$\lambda = \frac{0.693}{t_{\frac{1}{2}}}$

Answer **all** the questions in the spaces provided.

- 1 Measurements made for a sample of metal wire are shown in Fig. 1.1.

quantity	measurement	uncertainty
length	1750 mm	± 3 mm
diameter	0.38 mm	± 0.01 mm
resistance	7.5Ω	$\pm 0.2 \Omega$

Fig. 1.1

- (a) State the appropriate instruments used to make each of these measurements.

- (i) length

..... [1]

- (ii) diameter

..... [1]

- (iii) resistance

..... [1]

- (b) (i) Show that the resistivity of the metal is calculated to be $4.86 \times 10^{-7} \Omega \text{ m}$.

[2]

- (ii) Calculate the uncertainty in the resistivity.

uncertainty = \pm $\Omega \text{ m}$ [4]

- (c) Use the answers in (b) to express the resistivity with its uncertainty to the appropriate number of significant figures.

resistivity = \pm Ωm [1]

2 (a) Explain what is meant by *work done*.

.....
 [1]

(b) A car is travelling along a road that has a uniform downhill gradient, as shown in Fig. 2.1.

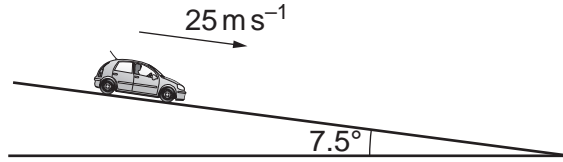

Fig. 2.1

The car has a total mass of 850 kg. The angle of the road to the horizontal is 7.5°.

Calculate the component of the weight of the car down the slope.

component of weight = N [2]

(c) The car in (b) is travelling at a constant speed of 25 ms⁻¹. The driver then applies the brakes to stop the car. The constant force resisting the motion of the car is 4600 N.

(i) Show that the deceleration of the car with the brakes applied is 4.1 ms⁻².

[2]

(ii) Calculate the distance the car travels from when the brakes are applied until the car comes to rest.

distance = m [2]

(iii) Calculate

1. the loss of kinetic energy of the car,

loss of kinetic energy = J [2]

2. the work done by the resisting force of 4600 N.

work done = J [1]

(iv) The quantities in (iii) part 1 and in (iii) part 2 are not equal. Explain why these two quantities are not equal.

.....

..... [1]

3 (a) Explain what is meant by *centre of gravity*.

.....
 [2]

(b) Define *moment* of a force.

.....
 [1]

(c) A student is being weighed. The student, of weight W , stands 0.30 m from end A of a uniform plank AB, as shown in Fig. 3.1.

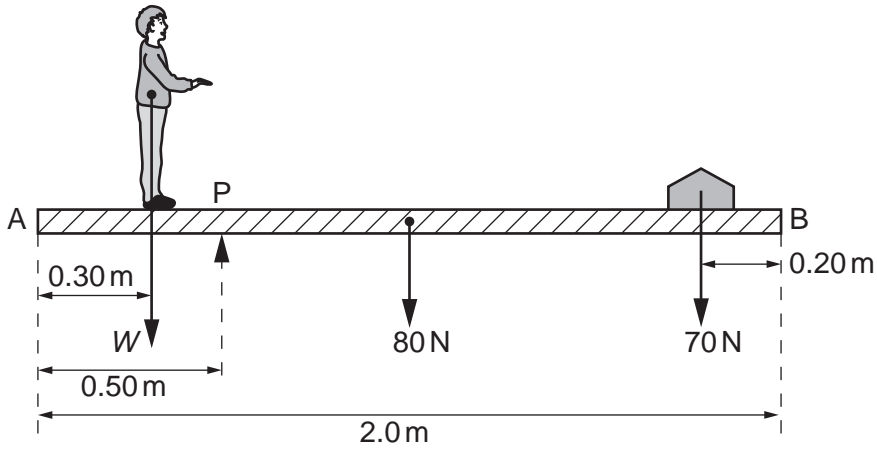

Fig. 3.1 (not to scale)

The plank has weight 80 N and length 2.0 m. A pivot P supports the plank and is 0.50 m from end A.

A weight of 70 N is moved to balance the weight of the student. The plank is in equilibrium when the weight is 0.20 m from end B.

(i) State the two conditions necessary for the plank to be in equilibrium.

1.

 2.

[2]

(ii) Determine the weight W of the student.

$W = \dots\dots\dots$ N [3]

(iii) If only the 70 N weight is moved, there is a maximum weight of student that can be determined using the arrangement shown in Fig. 3.1. State and explain **one** change that can be made to increase this maximum weight.

.....
.....
..... [2]

4 (a) Define, for a wire,

(i) *stress*,

.....
 [1]

(ii) *strain*.

.....
 [1]

(b) A wire of length 1.70 m hangs vertically from a fixed point, as shown in Fig. 4.1.

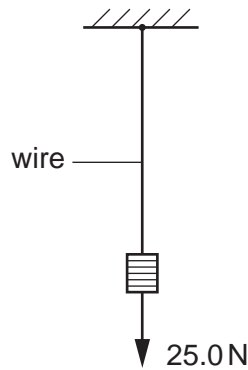

Fig. 4.1

The wire has cross-sectional area $5.74 \times 10^{-8} \text{ m}^2$ and is made of a material that has a Young modulus of $1.60 \times 10^{11} \text{ Pa}$. A load of 25.0 N is hung from the wire.

(i) Calculate the extension of the wire.

extension = m [3]

(ii) The same load is hung from a second wire of the same material. This wire is twice the length but the **same volume** as the first wire. State and explain how the extension of the second wire compares with that of the first wire.

.....

 [3]

- 5 (a) A variable resistor is used to control the current in a circuit, as shown in Fig. 5.1.

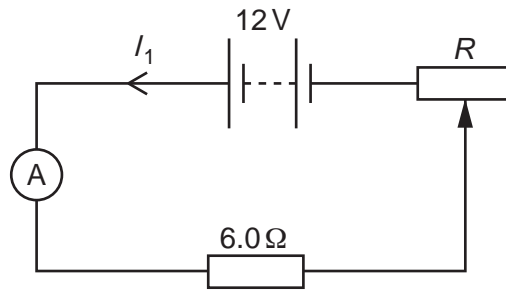

Fig. 5.1

The variable resistor is connected in series with a 12V power supply of negligible internal resistance, an ammeter and a 6.0Ω resistor. The resistance R of the variable resistor can be varied between 0 and 12Ω .

- (i) The maximum possible current in the circuit is 2.0A. Calculate the minimum possible current.

minimum current = A [2]

- (ii) On Fig. 5.2, sketch the variation with R of current I_1 in the circuit.

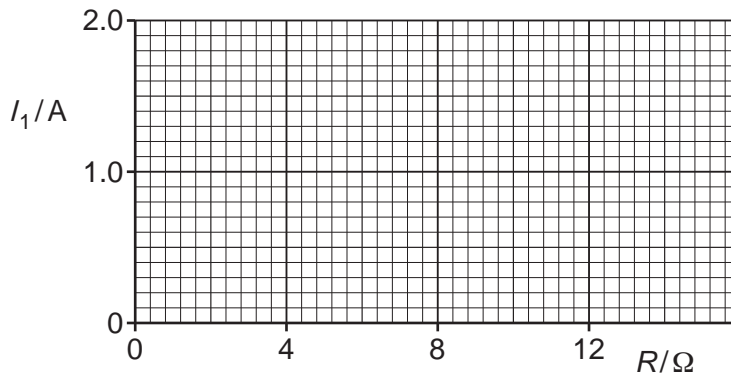

Fig. 5.2

[2]

(b) The variable resistor in (a) is now connected as a potential divider, as shown in Fig. 5.3.

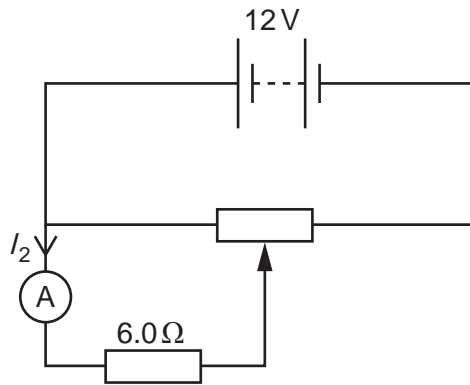

Fig. 5.3

Calculate the maximum possible and minimum possible current I_2 in the ammeter.

maximum $I_2 = \dots\dots\dots$ A

minimum $I_2 = \dots\dots\dots$ A

[2]

(c) (i) Sketch on Fig. 5.4 the $I - V$ characteristic of a filament lamp.

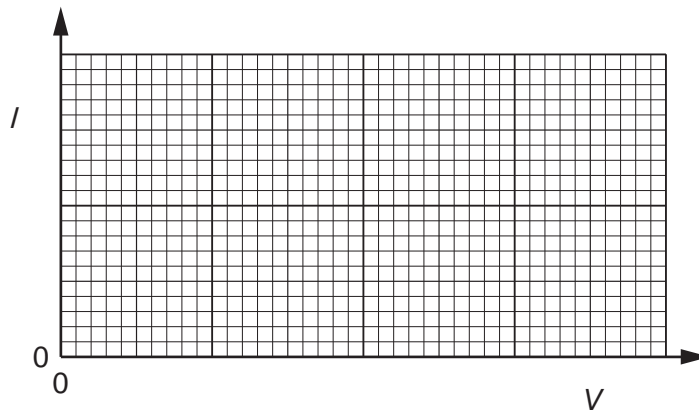

Fig. 5.4

[2]

- (ii) The resistor of resistance 6.0Ω is replaced with a filament lamp in the circuits of Fig. 5.1 and Fig. 5.3. State an advantage of using the circuit of Fig. 5.3, compared to the circuit of Fig 5.1, when using the circuits to vary the brightness of the filament lamp.

.....
.....
..... [1]

6 (a) State two assumptions of the simple kinetic model of a gas.

1.

.....

2.

.....

[2]

(b) Use the kinetic model of gases and Newton's laws of motion to explain how a gas exerts a pressure on the sides of its container.

.....

.....

.....

.....

..... [3]

7 (a) Explain the term *interference*.

.....
.....
..... [1]

(b) A ripple tank is used to demonstrate interference between water waves.

Describe

(i) the apparatus used to produce two sources of coherent waves that have circular wavefronts,

.....
.....
.....
..... [2]

(ii) how the pattern of interfering waves may be observed.

.....
.....
.....
..... [2]

(c) A wave pattern produced in (b) is shown in Fig. 7.1.

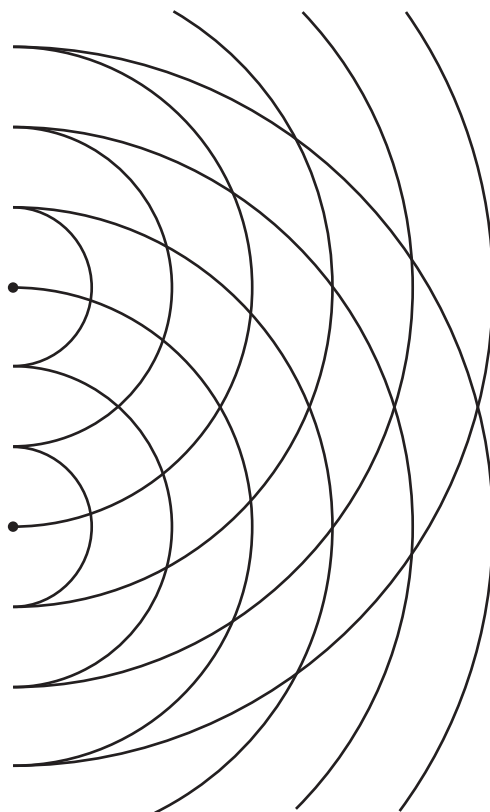

Fig. 7.1

Solid lines on Fig. 7.1 represent crests.

On Fig. 7.1,

- (i) draw two lines to show where maxima would be seen (label each of these lines with the letter X), [1]
- (ii) draw one line to show where minima would be seen (label this line with the letter N). [1]