

Chemical Energetics

Question Paper 2

Level	IGCSE
Subject	Chemistry
ExamBoard	CIE
Topic	Chemical Energetics
Sub-Topic	
Paper	(Extended) Theory
Booklet	Question Paper 2

TimeAllowed: 86 minutes

Score: / 71

Percentage: /100

- 1 (a) The following are two examples of substitution reactions. Only the reaction involving chlorine is a photochemical reaction.

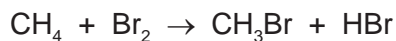
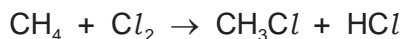

- (i) Explain the phrase *substitution reaction*.

.....
..... [1]

- (ii) How do photochemical reactions differ from other reactions?

.....
..... [1]

- (b) Bond forming is exothermic, bond breaking is endothermic. Explain the difference between an exothermic reaction and an endothermic reaction.

.....
..... [2]

- (c) Use the bond energies to show that the following reaction is exothermic.
Bond energy is the amount of energy (kJ/mol) which must be supplied to break one mole of the bond.

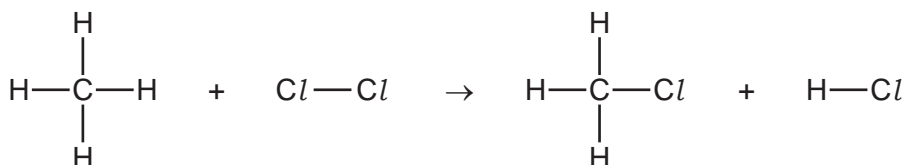

Bond energies in kJ/mol

Cl–Cl +242

C–Cl +338

C–H +412

H–Cl +431

bonds broken energy in kJ/mol

.....

.....

total energy =

bonds formed energy in kJ/mol

.....

.....

total energy =

.....

..... [4]

[Total: 8]

2 The diagram shows a simple cell.

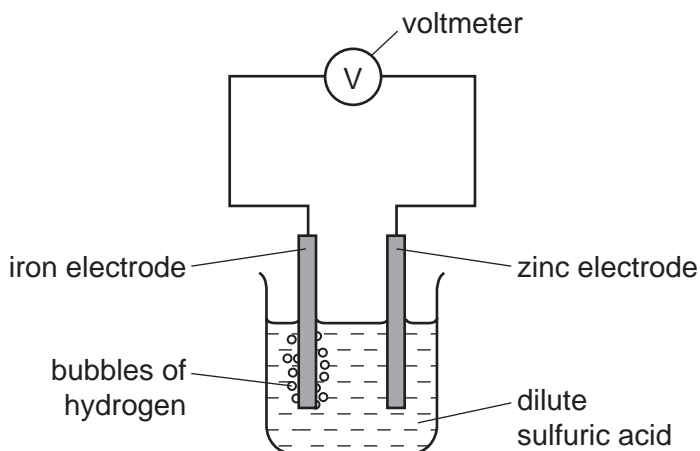

(a) Write an equation for the overall reaction occurring in the cell.

..... [2]

(b) Explain why all cell reactions are exothermic and redox.

.....
.....
..... [3]

(c) Which electrode, zinc or iron, is the negative electrode? Give a reason for your choice.

.....
..... [2]

(d) Suggest **two** ways of increasing the voltage of this cell.

.....
..... [2]

[Total: 9]

3 Some hydroxides, nitrates and carbonates decompose when heated.

(a) Name a metal hydroxide which does not decompose when heated.

..... [1]

(ii) Write the equation for the thermal decomposition of copper(II) hydroxide.

..... [2]

(iii) Suggest why these two hydroxides behave differently.

..... [1]

(b) Metal nitrates, except those of the Group 1 metals, form three products when heated. Name the products formed when zinc nitrate is heated.

.....
..... [2]

(ii) Write the equation for the thermal decomposition of potassium nitrate.

..... [2]

(c) There are three possible equations for the thermal decomposition of sodium hydrogencarbonate.



The following experiment was carried out to determine which one of the above is the correct equation.

A known mass of sodium hydrogencarbonate was heated for ten minutes. It was then allowed to cool and weighed.

Results

Mass of sodium hydrogencarbonate = 3.36 g

Mass of the residue = 2.12 g

Calculation

M_r for $\text{NaHCO}_3 = 84 \text{ g}$; M_r for $\text{Na}_2\text{O} = 62 \text{ g}$; M_r for $\text{NaOH} = 40 \text{ g}$

M_r for $\text{Na}_2\text{CO}_3 = 106 \text{ g}$

(i) Number of moles of NaHCO_3 used = [1]

(ii) If residue is Na_2O , number of moles of Na_2O =

If residue is NaOH , number of moles of NaOH =

If residue is Na_2CO_3 , number of moles of Na_2CO_3 = [2]

(iii) Use the number of moles calculated in **(i)** and **(ii)** to decide which one of the three equations is correct. Explain your choice.

.....

.....

..... [2]

[Total: 13]

4 Fuel cells are used in spacecraft to produce electrical energy.

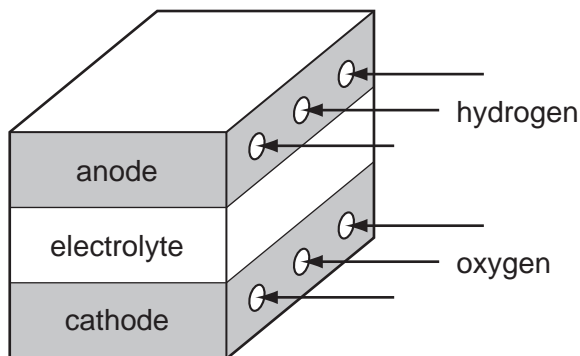

(a) How is oxygen obtained from liquid air?

.....
 [2]

(b) Hydrogen and oxygen react to form water.

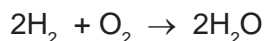

(i) Give an example of bond breaking in the above reaction.

..... [1]

(ii) Give an example of bond forming in the above reaction.

..... [1]

(iii) Is the change given in (i) exothermic or endothermic?

..... [1]

(c) (i) Give **two** reasons why hydrogen may be considered to be the ideal fuel for the future.

.....

 [2]

(ii) Suggest a reason why hydrogen is not widely used at the moment.

.....
 [1]

[Total: 8]

- 5 Hydrogen reacts with the halogens to form hydrogen halides.
- (a) Bond energy is the amount of energy, in kJ, that must be supplied (endothermic) to break one mole of a bond.

bond	bond energy in kJ/mol
H–H	
Cl–Cl	+2
H–Cl	+4

Use the above data to show that the following reaction is exothermic.

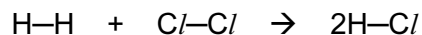

.....

.....

.....

.....

.....

.....

[3]

(b) They react with water to form acidic solutions.

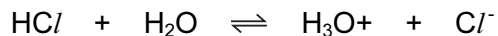

(i) Explain why water behaves as a base in both of these reactions.

.....
..... [2]

(ii) At equilibrium, only 1% of the hydrogen chloride exists as molecules, the rest has formed ions. In the other equilibrium, 97% of the hydrogen fluoride exists as molecules, only 3% has formed ions.

What does this tell you about the strength of each acid?

.....
..... [2]

(iii) How would the pH of these two solutions differ?

..... [1]

[Total: 8]

6 Three of the factors that can influence the rate of a chemical reaction are:

- physical state of the reactants
- light
- the presence of a catalyst

(a) The first recorded dust explosion was in a flour mill in Italy in 1785. Flour contains carbohydrates. Explosions are very fast exothermic reactions.

(i) Use the collision theory to explain why the reaction between the particles of flour and the oxygen in the air is very fast.

.....
 [2]

(ii) Write a word equation for this exothermic reaction.

..... [1]

The decomposition of silver(I) bromide is the basis of film photography. The equation for this decomposition is:

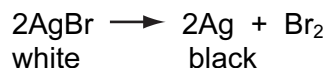

This reaction is photochemical.

A piece of white paper was coated with silver(I) bromide and the following experiment was carried out.

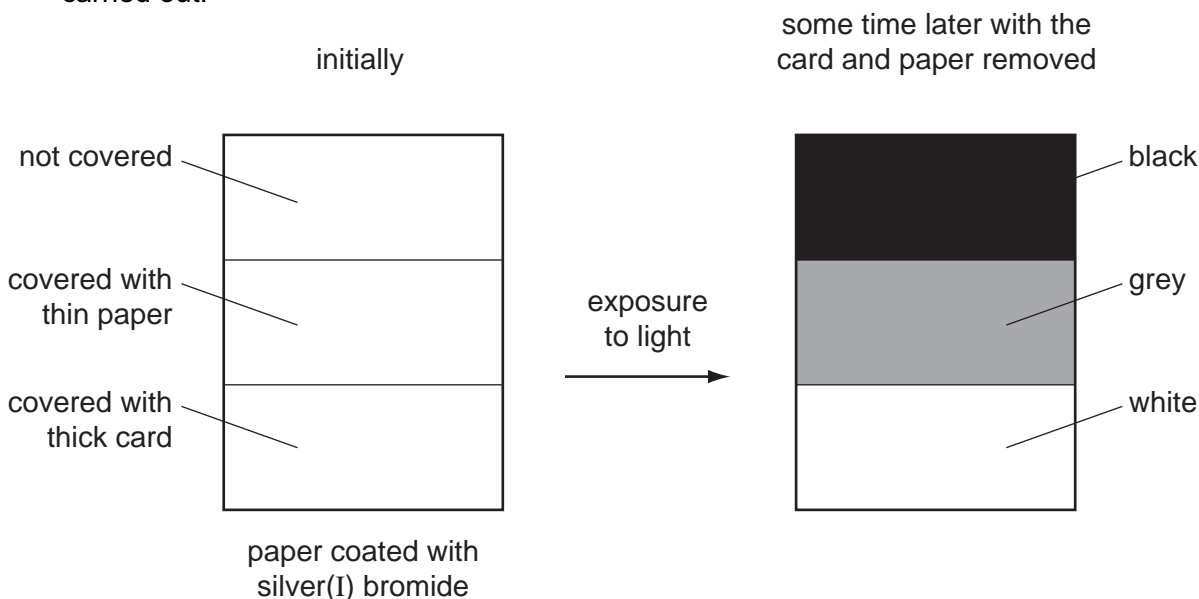

(b) Explain the results.

.....

 [3]

- (c) The fermentation of glucose is catalysed by enzymes from yeast. Yeast is added to aqueous glucose, the solution starts to bubble and becomes cloudy as more yeast cells are formed.

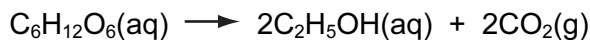

The reaction is exothermic.

Eventually the fermentation stops when the concentration of ethanol is about 12%.

- (i) What is an enzyme?

..... [1]

- (ii) Pasteur said that fermentation was respiration in the absence of air. Suggest a definition of *respiration*.

.....
..... [2]

- (iii) On a large scale, the reaction mixture is cooled. Suggest a reason why this is necessary.

..... [1]

- (iv) Why does the fermentation stop? Suggest **two** reasons.

.....
..... [2]

- (v) When the fermentation stops, there is a mixture of dilute aqueous ethanol and yeast. Suggest a technique which could be used to remove the cloudiness due to the yeast.

..... [1]

Name a technique which will separate the ethanol from the ethanol/water mixture.

..... [1]

[Total: 14]

- 7 (a) (i) Write a symbol equation for the action of heat on zinc hydroxide.

[2]

- (ii) Describe what happens when solid **sodium** hydroxide is heated strongly.

[1]

- (b) What would be **observed** when copper(II) nitrate is heated?

[3]

- (c) Iron(III) sulphate decomposes when heated. Calculate the mass of iron(III) oxide formed and the volume of sulphur trioxide produced when 10.0 g of iron(III) sulphate was heated.

Mass of one mole of $\text{Fe}_2(\text{SO}_4)_3$ is 400 g.



Number of moles of $\text{Fe}_2(\text{SO}_4)_3$ =	
Number of moles of Fe_2O_3 formed =	
Mass of iron(III) oxide formed =	g
Number of moles of SO_3 produced =	
Volume of sulphur trioxide at r.t.p. =	dm^3

[5]