

# Mains Electricity

## Question paper 2

<b>Level</b>	IGCSE(9-1)
<b>Subject</b>	Physics
<b>Exam Board</b>	Edexcel IGCSE
<b>Module</b>	Double Award (Paper 1P)
<b>Topic</b>	Electricity
<b>Sub-Topic</b>	Mains Electricity
<b>Booklet</b>	Question paper 2

**Time Allowed:** 81 minutes

**Score:** /67

**Percentage:** /100

**Grade Boundaries:**

A*	A	B	C	D	E	U
>85%	'75%	70%	60%	55%	50%	<50%

- 1 (a) A student investigates the resistance of a lamp.
- (i) The student uses a circuit that contains an ammeter, a battery, a lamp and a voltmeter to determine the resistance of the lamp.

Draw a circuit diagram to show how he should connect the apparatus.

(3)

- (ii) State the relationship between voltage, current and resistance.

(1)

- (iii) The student obtains this graph for a filament lamp.

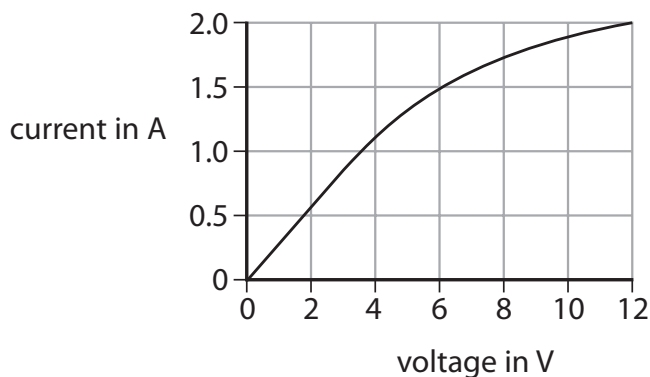

Calculate the resistance of the lamp when the voltage is 6.0 V.

Give the unit.

(3)

resistance = ..... unit .....

(iv) The student reverses the battery connections and then repeats his measurements.

On the axes below, sketch the graph that he would obtain.

Part of the graph has been done for you.

(2)

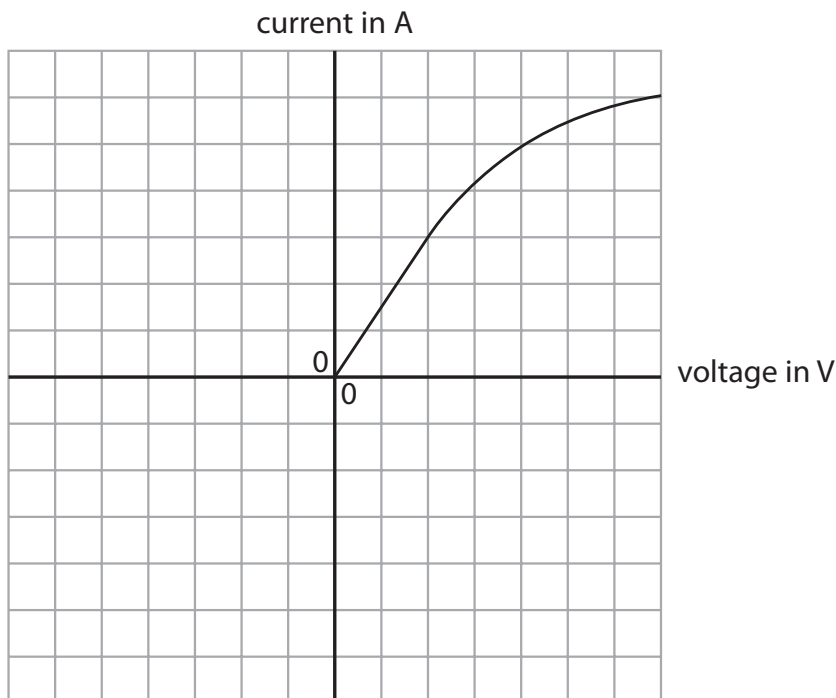

(b) The student replaces the filament lamp with a light emitting diode (LED). He notices that there is no current in the diode when the battery is reversed. He replaces the battery with an a.c. supply.

Which graph shows how the current in the diode varies with time?

(1)

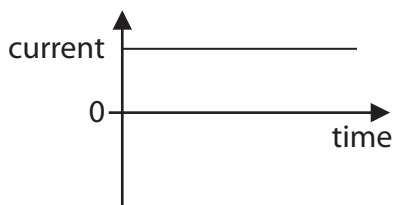

A

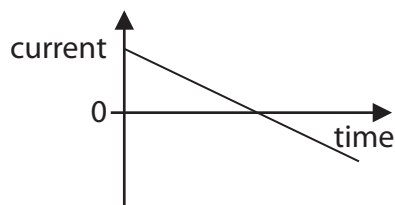

B

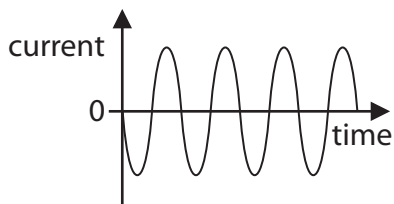

C

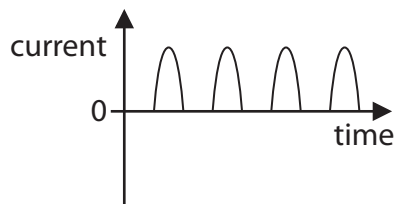

D

(Total for Question 1 = 10 marks)

2 Mains electricity is used in circuits at home.

(a) Double insulation is needed for safety when there is (1)

- A no circuit breaker
- B no earth connection
- C no fuse
- D no switch

(b) A fuse is used so that (1)

- A an earth connection is not needed
- B the appliances are more efficient
- C the circuit cannot overheat if there is a fault
- D the user cannot touch a live wire

(c) Most lamps at home have their own switch.

This is because the lamps are connected (1)

- A in parallel
- B in series
- C to a fuse
- D to an earth wire

**(Total for Question 2 = 3 marks)**

3 A student investigates how the resistance of a wire depends on its length.

The photograph shows the circuit that the student uses.

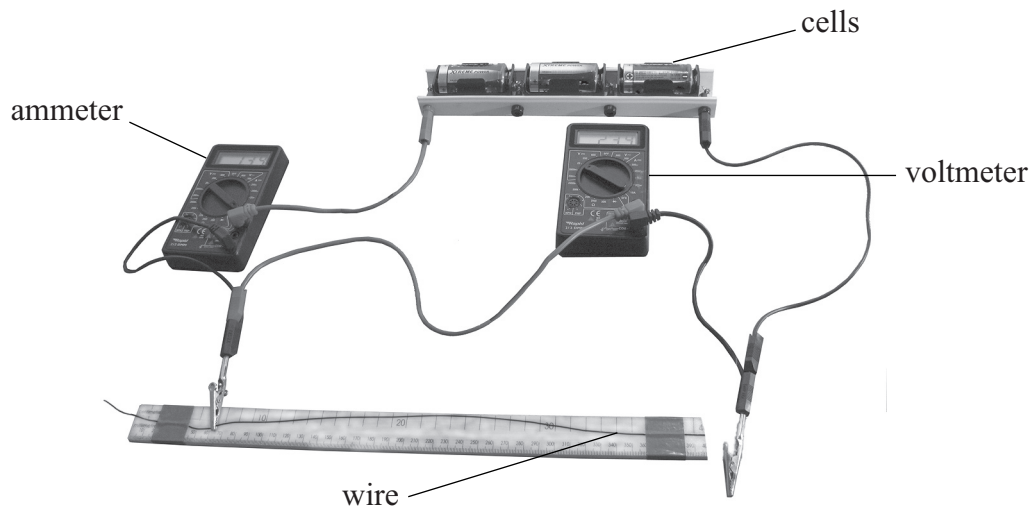

(a) Draw a circuit diagram to show how the components in the photograph are connected.

(3)



(c) The table shows the student's measurements.

Length of wire in cm	Voltage in V	Current in A	Resistance of wire in $\Omega$
20	4.5	3.6	1.3
40	4.5	1.8	2.5
60	4.5	1.2	3.8
80	4.5	0.9	5.0
100	4.5	0.7	

(i) State the equation linking voltage, current and resistance.

(1)

(ii) Complete the table by calculating the missing value of resistance.

(1)

- (d) (i) Use the results from the table opposite to plot a graph of resistance ( $y$ -axis) against length of wire ( $x$ -axis) and draw the line of best fit.

(5)

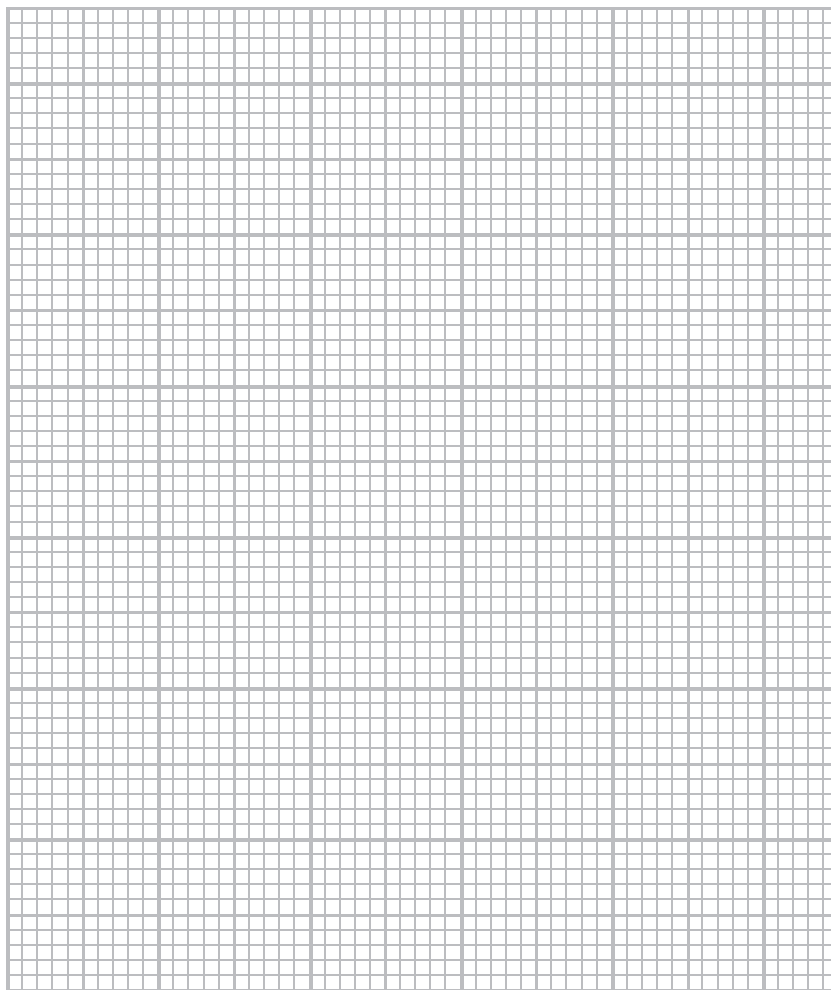

- (ii) Write a conclusion for the investigation.

(1)

.....

.....

- (iii) Explain how the graph supports this conclu

(2)

.....

.....

.....

(Total for Question 3 = 19 marks)



4 The diagram shows the lighting circuit in an office.

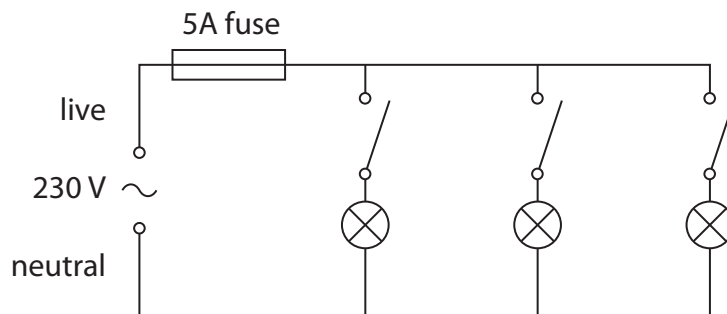

(a) (i) State two advantages of connecting lamps in parallel rather than in series.

(2)

1 .....

.....

2 .....

.....

(ii) What is the purpose of the 5 A fuse?

(1)

.....

.....

(iii) Explain how a fuse works.

(3)

.....

.....

.....

.....

.....

.....

(b) A label on one of the office computers includes this information.

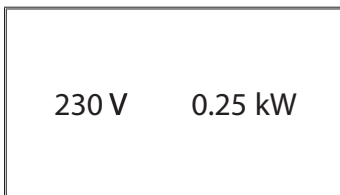

(i) State the equation linking power, current and voltage. (1)

(ii) Use the information on the label to calculate the current in the computer. (3)

current = ..... A

(iii) Fuses are available with values of 1 A, 3 A, 10 A and 13 A.

Suggest the most suitable fuse value for the computer.

Give a reason for your answer.

(2)

fuse value ..... A

reason .....

.....

(iv) Some circuits use a circuit breaker instead of a fuse.

State two advantages of using a circuit breaker instead of a fuse.

(2)

1 .....

.....

2 .....

.....

(c) The graphs show some ways that power ( $P$ ) can vary with voltage ( $V$ ).

Which is the correct graph for a fixed resistor?

(1)

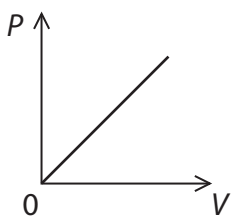

A

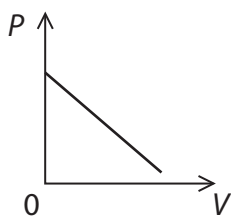

B

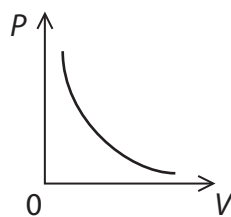

C

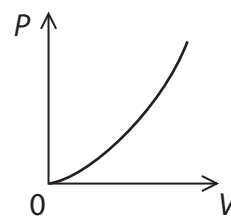

D

(Total for Question 4 = 15 marks)



(b) (i) Describe two ways to increase the speed of rotation of the coil in this motor. (2)

1 .....

.....

2 .....

.....

(ii) Suggest how to make the coil spin in the opposite direction. (1)

.....

.....

(c) In a different motor, the magnets are curved and there is a piece of iron inside the coil. The iron increases the strength of the magnetic field through the coil.

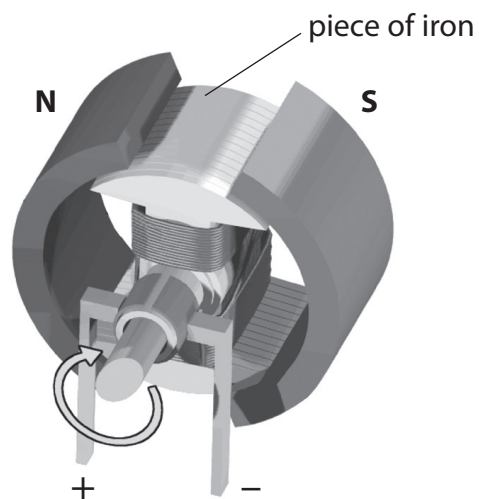

Suggest how the curved magnets and the piece of iron improve the performance of the electric motor. (2)

.....

.....

.....

.....

.....

.....

6 Photograph E shows a rechargeable torch.

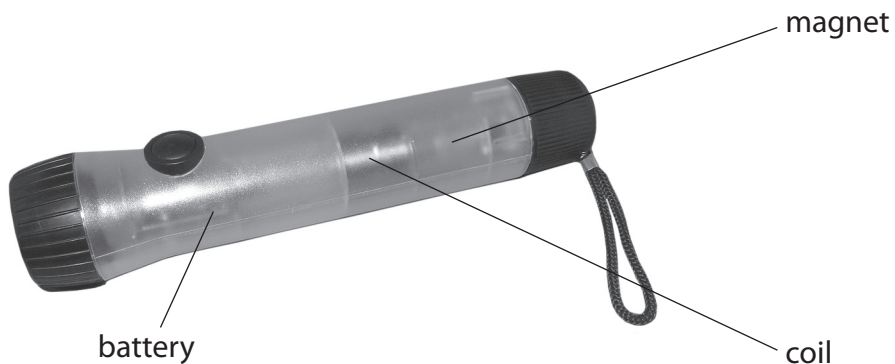

Photograph E

- (a) When a student shakes the torch, the magnet moves through the coil and back again. This induces a voltage across the ends of the coil. The voltage is used to provide current to recharge the battery.

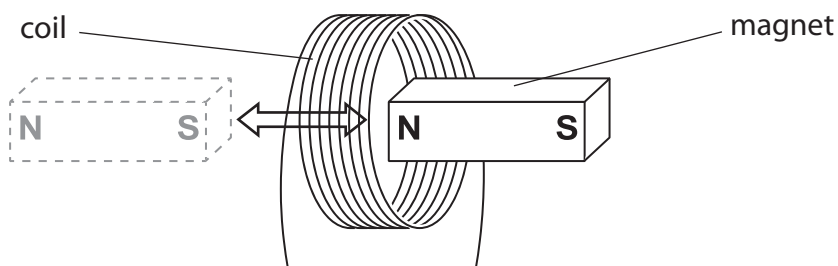

(i) Explain why a voltage is induced.

(2)

.....

.....

.....

.....

.....

(ii) State **one** way to increase this voltage.

(1)

.....

.....

.....

.....

(b) Photograph F shows the components inside the torch.

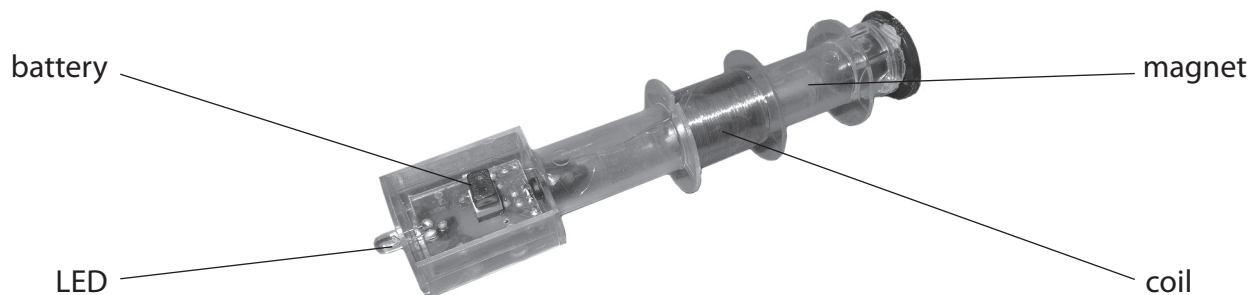

Photograph F

The torch uses a light-emitting diode (LED) to provide light.

(i) When the LED is on, it shows that

(1)

- A the current is alternating
- B the torch is switched off
- C there is a current in the circuit
- D there is a fault in the circuit

(ii) The manufacturer of the torch states, "An LED is a more efficient source of light than a filament lamp."

Explain this statement in terms of energy transfer.

(2)

.....

.....

.....

.....

.....

---

**(Total for Question 6 = 6 marks)**

7 (a) The diagram shows some electrical circuit symbols.



**A**



**B**



**C**

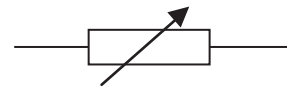

**D**

(i) Which symbol represents a switch?

(1)

**A**

**B**

**C**

**D**

(ii) Which symbol represents a diode?

(1)

**A**

**B**

**C**

**D**



(b) A hairdryer connected to the mains supply takes a current of 5.5 A.

(i) Which of these fuses should be used with the hairdryer?

(1)

A 3 A

B 5 A

C 7 A

D 13 A

(ii) Explain our answer.

(1)

.....

.....

.....

(iii) The hairdryer has a plastic case so there is no need for an earth wire connection in the plug.

Explain why the hairdryer is still safe to use.

(2)

.....

.....

.....

.....

.....

.....

**(Total for Question 7 = 6 marks)**