

# Forces, movement, shape and momentum

## Question paper 5

<b>Level</b>	IGCSE(9-1)
<b>Subject</b>	Physics
<b>Exam Board</b>	Edexcel IGCSE
<b>Module</b>	Single Award (Paper 2P)
<b>Topic</b>	Forces and motion
<b>Sub-Topic</b>	Forces, movement, shape and momentum
<b>Booklet</b>	Question paper 5

**Time Allowed:** 63 minutes

**Score:** /52

**Percentage:** /100

**Grade Boundaries:**

A*	A	B	C	D	E	U
>85%	'75%	70%	60%	55%	50%	<50%

1 A man uses a wheelbarrow to carry some logs along a flat path, as shown.

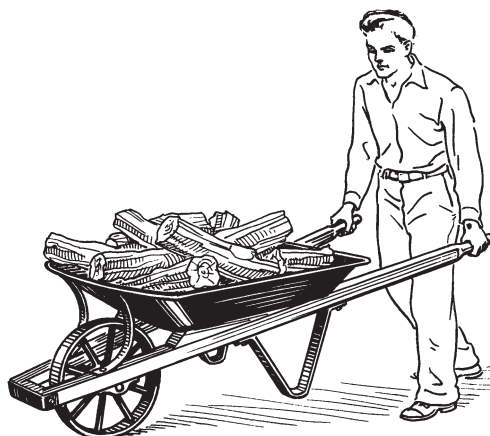

©[http://commons.wikimedia.org/wiki/file:wheelbarrow\\_%28PSF%29.png](http://commons.wikimedia.org/wiki/file:wheelbarrow_%28PSF%29.png)

(a) He pushes with a horizontal force of 140N and the wheelbarrow moves 39 m.

(i) State the relationship between work done, force and distance moved.

(1)

(ii) Calculate the work done moving the wheelbarrow.

(2)

work done = ..... J

(iii) State how much energy is transferred to the wheelbarrow.

(1)

energy transferred = ..... J

(b) The man stops and holds the wheelbarrow horizontally, as shown.

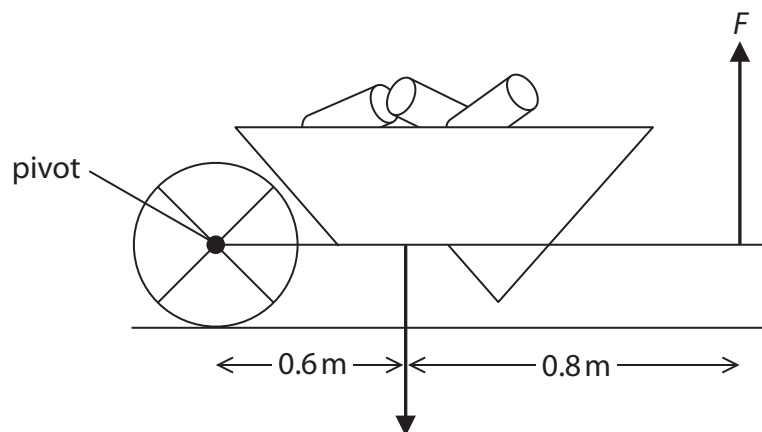

The man exerts a total upward force of  $F$  N.

The weight of the loaded wheelbarrow is 470 N.

(i) Mark X on the diagram to indicate the centre of gravity of the loaded wheelbarrow. (1)

(ii) State the equation linking moment, force and perpendicular distance from the pivot. (1)

(iii) Calculate the force  $F$ . (4)

force  $F$  = ..... N

**(Total for Question 1 = 10 marks)**

2 The photograph shows a hammer just before it hits a nail.



(a) The mass of the hammer is 0.50 kg.

When it hits the nail, the hammer is travelling downwards with a velocity of 3.1 m/s.

(i) State the relationship between momentum, mass and velocity. (1)

(ii) Calculate the momentum of the hammer. (2)

momentum = ..... kg m/s

(iii) The hammer stops quickly when it hits the nail.

The momentum of the hammer reduces to zero in 0.070 s.

Calculate the amount of force that causes this to happen. (2)

force = ..... N

(b) As it enters the wood, the nail exerts a force on the wood.

At the same time, the wood exerts a force on the nail.

Explain how these two forces are related.

(2)

.....

.....

.....

.....

.....

.....

(c) Both ends of the nail exert pressure when the nail goes into the wood.



Explain why the nail exerts more pressure on the wood than it does on the hammer.

(2)

.....

.....

.....

.....

.....

.....

**(Total for Question 2 = 9 marks)**

3 A toy train is placed on the middle of a bridge on a model railway.

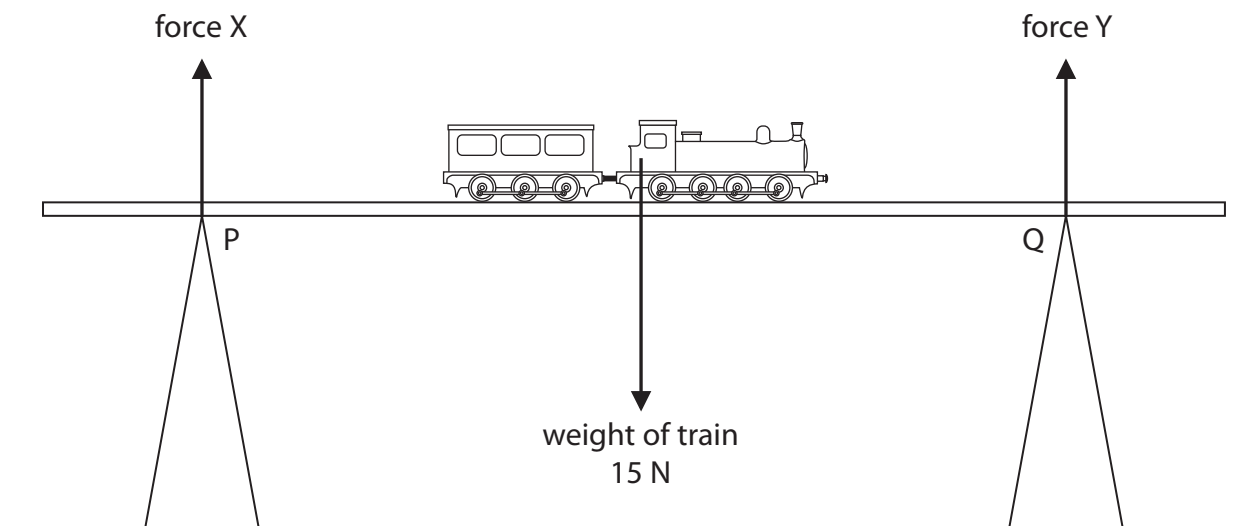

The weight of the train acts through its centre of gravity.

Ignore the weight of the bridge.

(a) Which row of the table shows the correct values for forces X and Y?

(1)

	force X	force Y
<input type="checkbox"/> A	7.5 N	7.5 N
<input type="checkbox"/> B	0 N	0 N
<input type="checkbox"/> C	0 N	15 N
<input type="checkbox"/> D	15 N	0 N

(b) Describe how force X changes if the train moves from P to Q.

(2)

.....

.....

.....

.....

**(Total for Question 3 = 3 marks)**

4 The diagram shows the apparatus used to investigate moments.

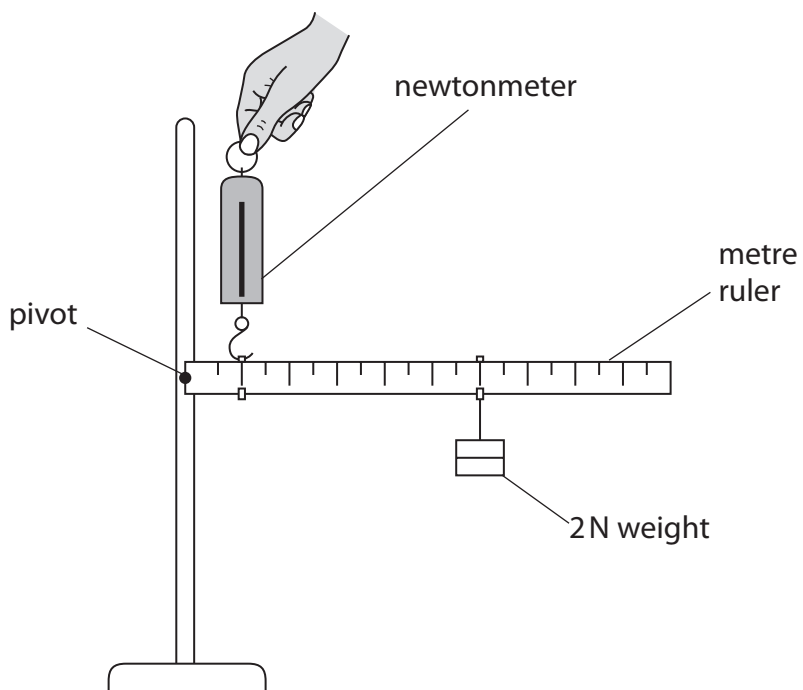

The 2 N weight is placed 60 cm from the pivot.

The newtonmeter is placed 10 cm from the pivot.

(a) (i) State the equation linking moment, force and perpendicular distance from the pivot.

(1)

(ii) Calculate the reading on the newtonmeter.

Ignore the weight of the ruler.

(3)

reading = ..... N

(b) The metre rule is replaced by an iron bar.

The iron bar is 1 m long and has a weight of 10 N.

The newtonmeter and the 2 N weight stay in their original position.

Explain how this change affects the reading on the newtonmeter.

**(3)**

.....

.....

.....

.....

.....

.....

.....

**(Total for Question 4 = 7 marks)**



5 (a) Which of these is a unit for the moment of a force? (1)

- A N
- B Nm
- C N/m
- D N/m<sup>2</sup>

(b) A painter sets up a uniform plank so he can paint a wall.

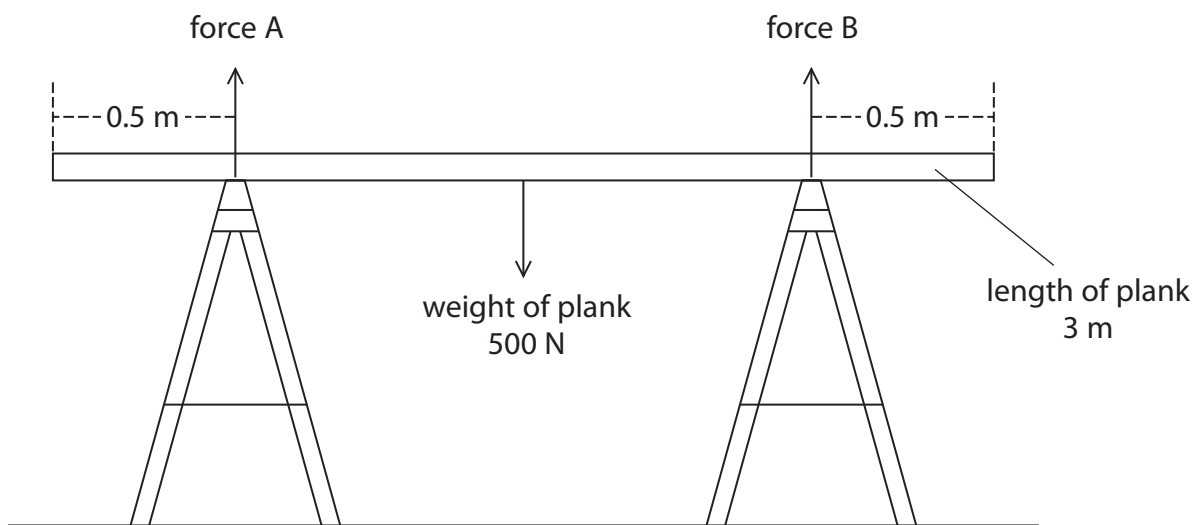

The plank is 3 m long and weighs 500 N.

(i) Use the principle of moments to show that the upward force A is 250 N. (4)

(ii) State the value of force B. (1)

force B = .....N

(c) The painter stands on the plank as shown.

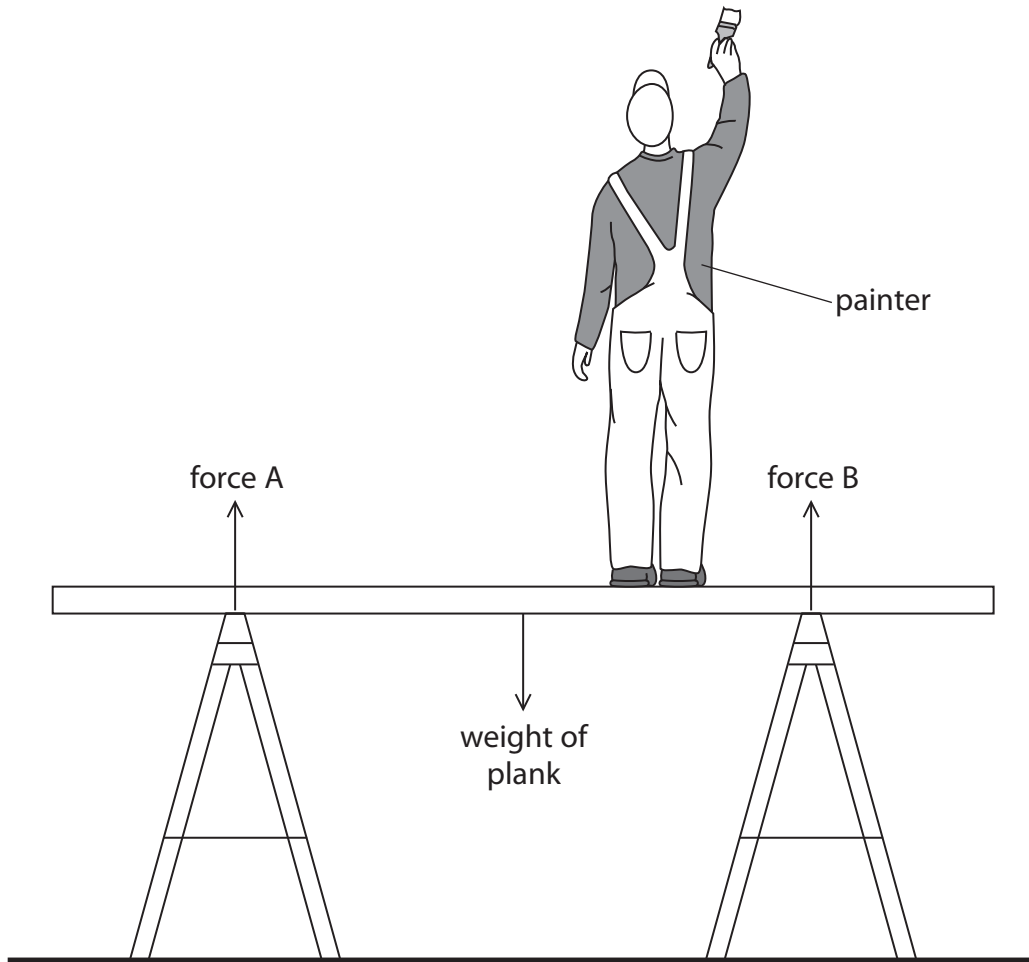

(i) Draw an arrow on the diagram to show the weight of the painter.

(1)

(ii) Describe the changes in forces A and B when the painter stands on the plank.

(2)

.....

.....

.....

.....

.....

.....

**(Total for Question 5 = 9 marks)**

- 6 A student investigates friction between a block of wood and different types of surface.
- (a) The student uses the equipment shown in photograph A to measure the force needed to move the block of wood.

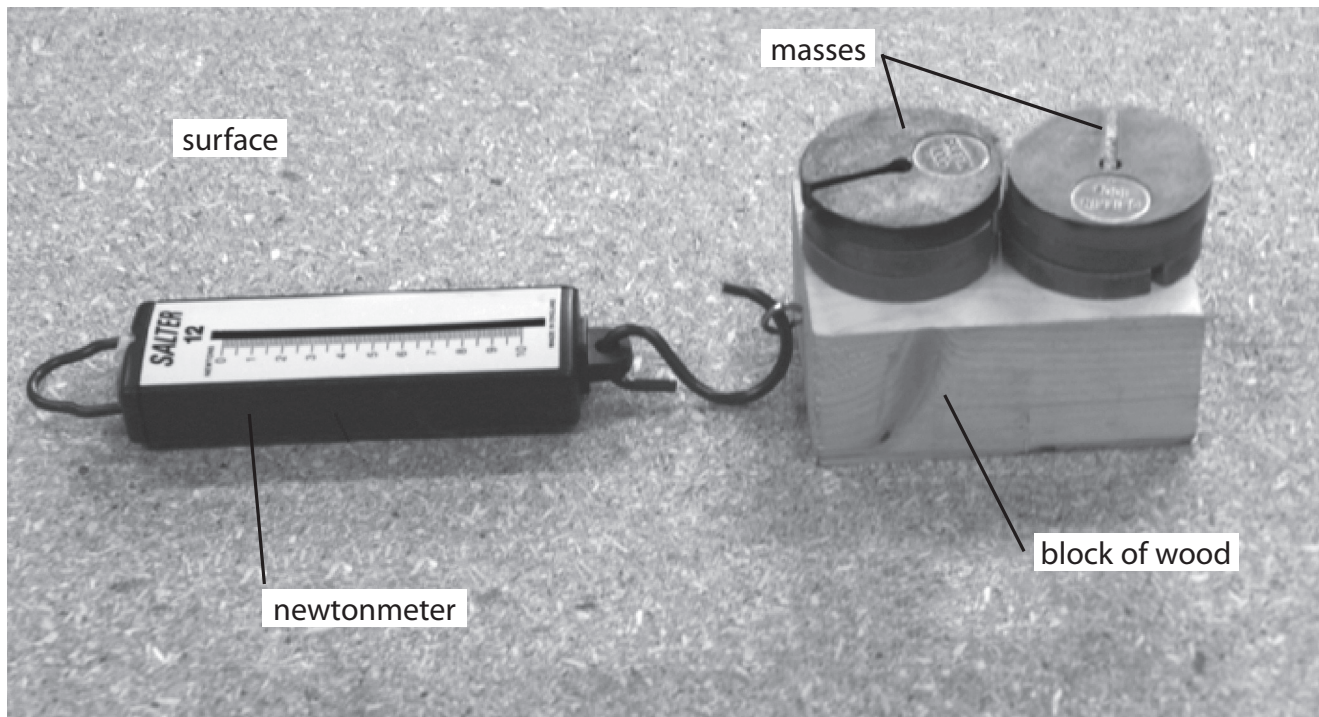

Photograph A

- (i) Suggest why the student places masses on the block. (1)

.....

.....

- (ii) Explain why he keeps the masses constant during the experiment. (1)

.....

.....

(b) The student investigates five different types of surface.

The table shows his results.

Type of surface	Force in N		
	1st reading	2nd reading	Average
chipboard	3.0	3.0	3.0
wood	2.5	2.5	2.5
coarse sandpaper	4.7	4.3	
fine sandpaper	5.6	5.8	5.7
ice	0.5	0.5	0.5

(i) Give an example of a non-continuous variable in this investigation.

(1)

.....

.....

(ii) Complete the table by inserting the missing average.

(1)

(iii) Display the average force results for this investigation on the grid.

(4)



(c) The student compares his results with others in the class.

He finds that they have different values for the forces.

Suggest why.

(2)

---

---

---

---

(d) The student repeats the investigation using another block of wood as shown in photograph B.

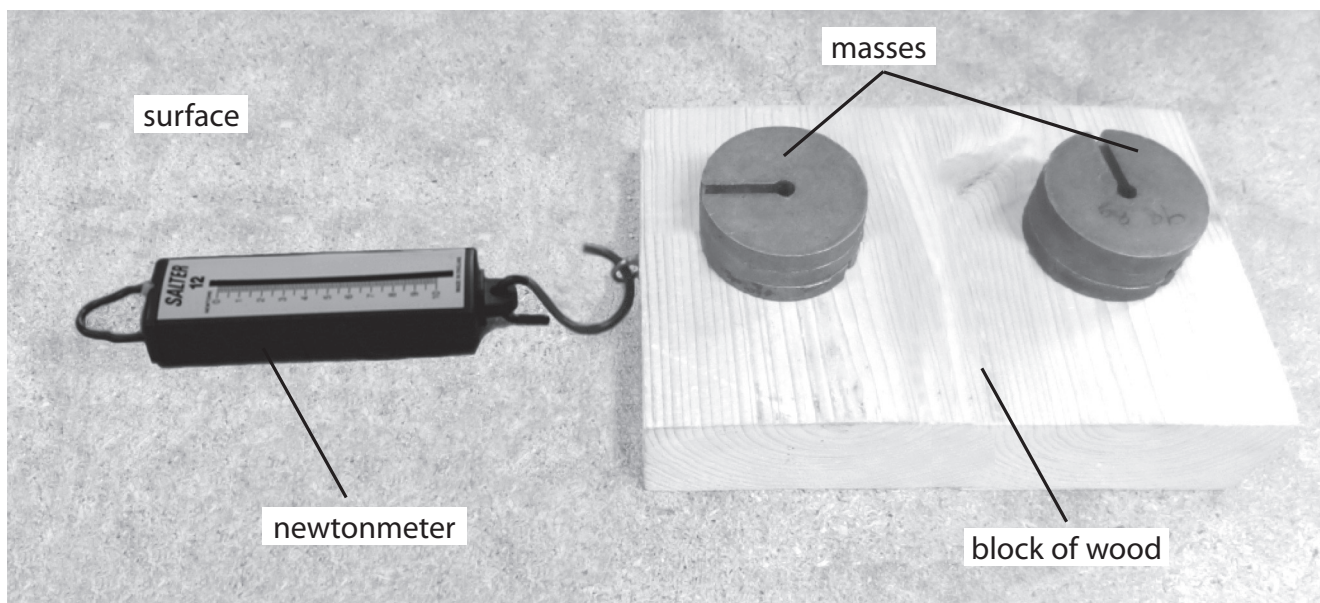

Photograph B

This block of wood has the same mass but a different area of contact.

Explain how this change affects the pressure on the surface.

(2)

---

---

---

---

(e) Suggest two ways in which the student could reduce friction between the two surfaces.

(2)

1 .....

.....

2 .....

.....

**(Total for Question 6 = 14 marks)**