

# Electromagnetism

## Question Paper 3

Level	A Level
Subject	Physics
Exam Board	OCR
Topic	Particles and medical physics
Sub-Topic	Electromagnetism
Booklet	Question Paper 3

**Time Allowed:** 54 minutes

**Score:** / 45

**Percentage:** /100

**Grade Boundaries:**

A*	A	B	C	D	E	U
>85%	'77.5%	70%	62.5%	57.5%	45%	<45%

1 (a) Define *magnetic flux*.

.....  
..... [1]

(b) Fig. 4.1 shows a generator coil of 500 turns and cross-sectional area  $2.5 \times 10^{-3} \text{m}^2$  placed in a magnetic field of magnetic flux density 0.035 T. The plane of the coil is perpendicular to the magnetic field.

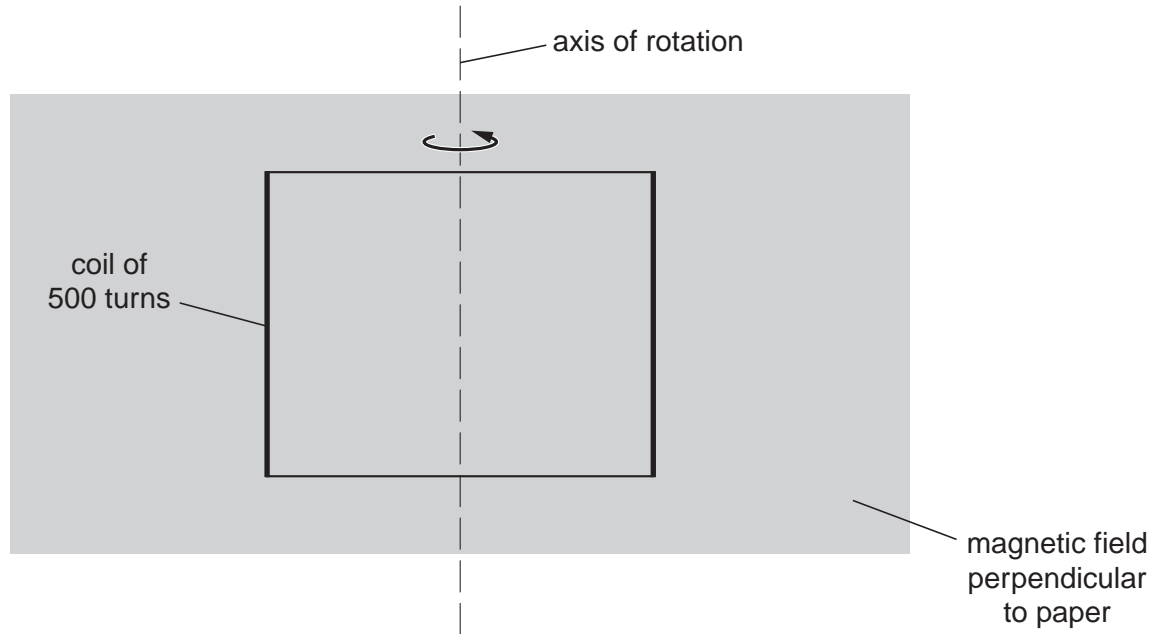

Fig. 4.1

Calculate the magnetic flux linkage for the coil in this position. Give a unit for your answer.

magnetic flux linkage = ..... unit ..... [3]

(c) The coil is rotated about the axis in the direction shown in Fig. 4.1.

Fig. 4.2 shows the variation of the magnetic flux  $\phi$  against time  $t$  as the coil is rotated.

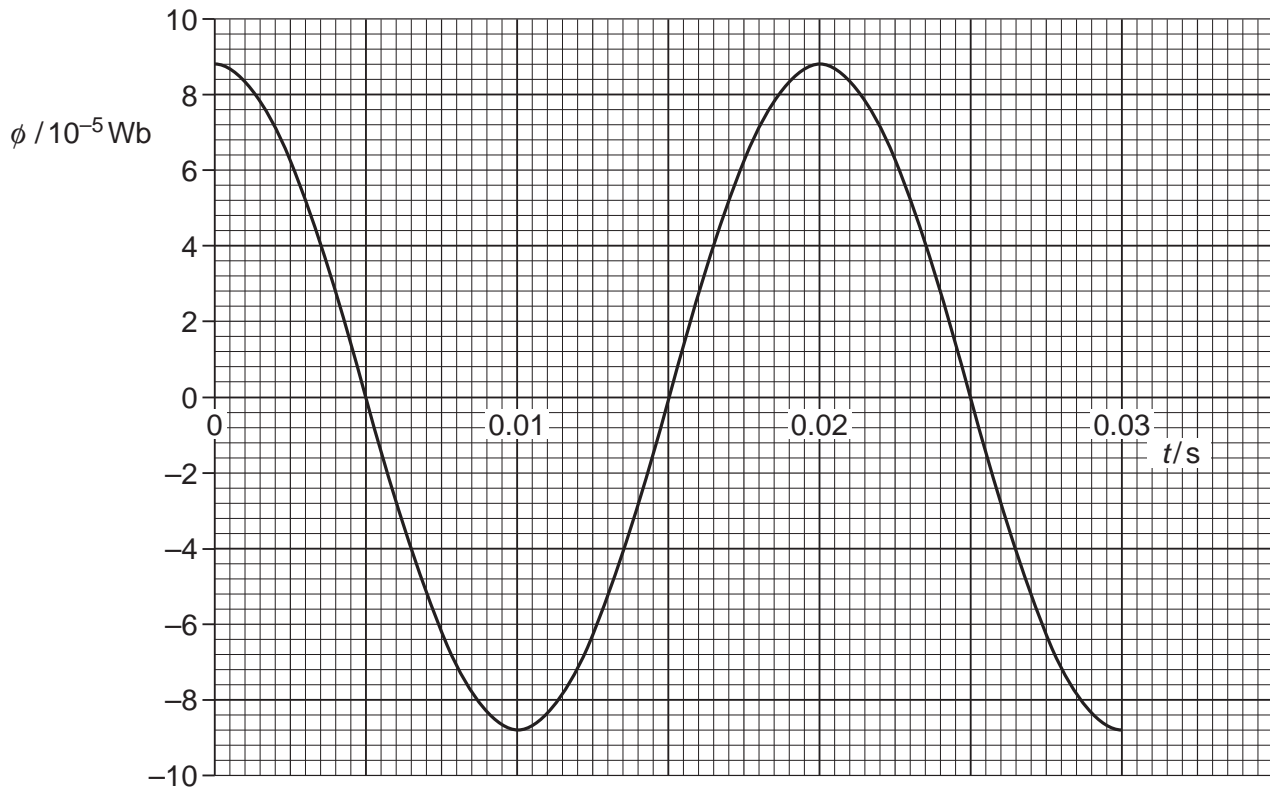

Fig. 4.2

(i) Explain why the magnitude of the magnetic flux through the coil varies as the coil rotates.

.....

.....

.....

..... [2]

(ii) State Faraday's law of electromagnetic induction.

.....  
..... [1]

(iii) Use Fig. 4.2 to describe and explain the variation with time of the induced e.m.f. across the ends of the coil.

.....  
.....  
.....  
.....  
..... [3]

(iv) Use Fig. 4.2 to determine the magnitude of the average induced e.m.f. for the coil between the times 0 s and 0.005 s.

average e.m.f. = ..... V [2]

(v) State and explain the effect on the magnitude of the maximum induced e.m.f. across the ends of the coil when the coil is rotated at twice the frequency.

.....  
.....  
..... [2]

[Total: 14]

2 Fig. 3.1 shows a section through a mass spectrometer.

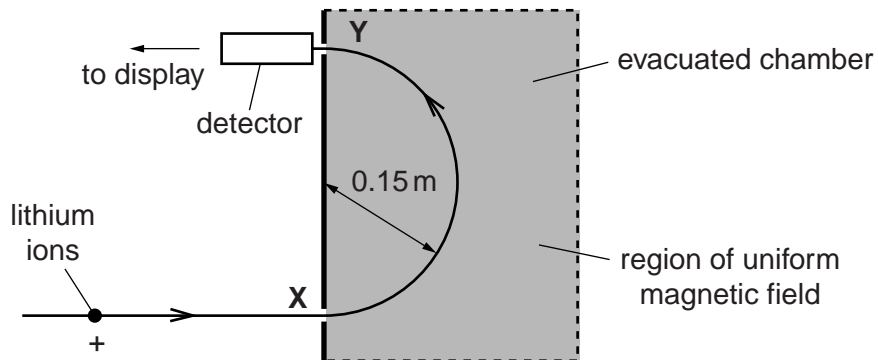

Fig. 3.1

A beam of positive lithium ions enter the evacuated chamber through the hole at X. The ions travel through a region of uniform magnetic field. The magnetic field is directed vertically into the plane of the diagram. The ions exit and are detected at Y.

(a) Name the rule that may be used to determine the direction of the force acting on the ions.

..... [1]

(b) Explain why the speed of the ions travelling from X to Y in the magnetic field does not change despite the force acting on the ions.

.....  
 .....  
 ..... [1]

(c) The lithium-7 ions are detected at Y. All the ions have the same speed,  $4.0 \times 10^5 \text{ m s}^{-1}$  and charge,  $+1.6 \times 10^{-19} \text{ C}$ . The radius of the semi-circular path of the ions in the magnetic field is 0.15 m. The mass of a lithium-7 ion is  $1.2 \times 10^{-26} \text{ kg}$ .

(i) Calculate the force acting on a lithium ion as it moves in the semi-circle.

force = .....N [2]

(ii) Calculate the magnitude of the magnetic flux density  $B$ .

$B = \dots\dots\dots$  T [2]

(iii) The current recorded by the detector at  $Y$  is  $4.8 \times 10^{-9}$  A. Calculate the number of lithium-7 ions reaching the detector per second.

number per second =  $\dots\dots\dots$  s<sup>-1</sup> [2]

(d) Fig. 3.2 shows the variation of current  $I$  in the detector with magnetic flux density  $B$ .

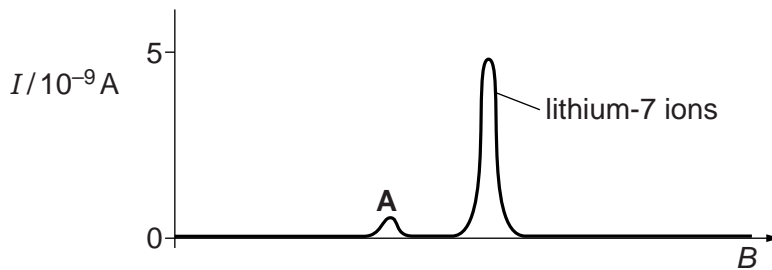

Fig. 3.2

The peak **A** is due to ions of another isotope of lithium. These ions have the same speed and charge as the lithium-7 ions. Explain the significance of the ‘height’ and position of peak **A**.

.....

.....

.....

.....

..... [2]

3 (a) Define *torque of a couple*.

.....  
 ..... [1]

(b) Fig. 2.1 shows a current-carrying square coil placed in a uniform magnetic field.

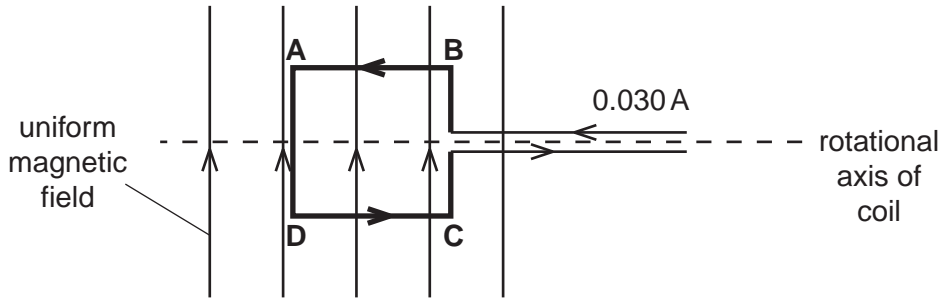

Fig. 2.1

The length of each side of the coil is 0.015 m. The plane of the coil is parallel to the magnetic field. The magnetic field is at right angles to the section **AB** of the coil and has magnetic flux density 0.060 T. The current in the coil is 0.030 A.

(i) Use Fleming's left-hand rule to determine the direction of the force on section **AB** of the coil.

..... [1]

(ii) The current-carrying coil will rotate because it experiences a torque. With the coil in the position shown in Fig. 2.1, calculate

1 the force experienced by the length **AB**

force = ..... N [1]

2 the torque experienced by the coil.

torque = ..... Nm [2]

(c) Fig. 2.2 shows the path of a positive ion of oxygen-16 inside a mass spectrometer.

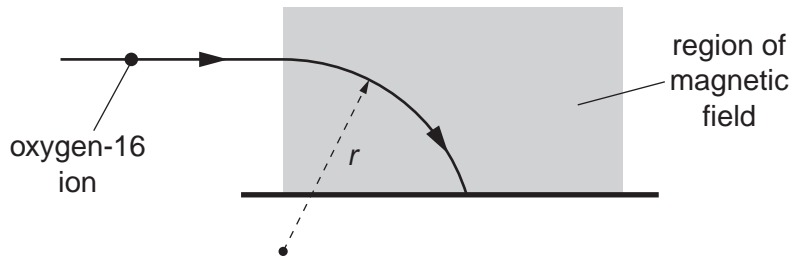

Fig. 2.2

The shaded area in Fig. 2.2 represents a region of uniform magnetic field of flux density 0.14 T. The direction of the magnetic field is out of the plane of the paper. The ion has a speed of  $4.5 \times 10^6 \text{ m s}^{-1}$  and it enters the region at right angles to the magnetic field. While the ion is in the magnetic field, it describes a circular arc of radius  $r$ . The force experienced by the ion in the magnetic field is  $2.0 \times 10^{-13} \text{ N}$ .

(i) Calculate the charge  $Q$  of the ion.

$Q = \dots\dots\dots \text{C}$  [2]

(ii) The mass of the ion is  $2.7 \times 10^{-26} \text{ kg}$ . Calculate the radius  $r$  of the circular path.

$r = \dots\dots\dots \text{m}$  [3]

(iii) In Fig. 2.2, the oxygen-16 ion is replaced by an oxygen-18 ion. The oxygen-18 ion has the same speed and charge. Explain why this ion describes an arc of greater radius.

.....  
 .....  
 .....  
 .....

[2]

[Total: 12]



4 (a) Define *magnetic flux*.

.....  
 ..... [2]

(b) Fig. 3.1 shows an experiment to demonstrate electromagnetic induction.

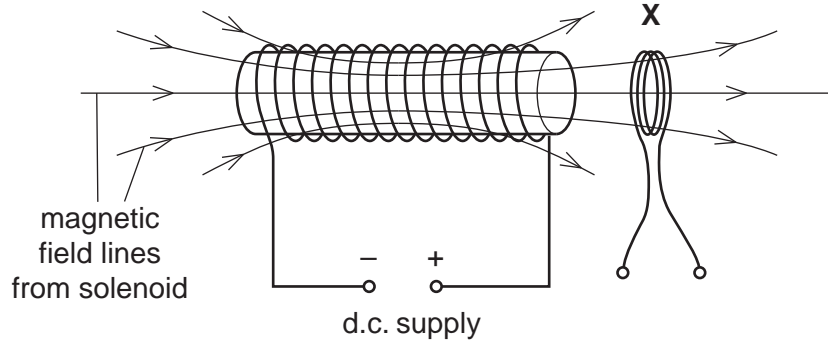

Fig. 3.1

The solenoid is connected to a variable voltage d.c. supply. A coil X is placed close to one end of the solenoid. The current in the solenoid is reduced. Fig. 3.2 shows the consequent variation of the magnetic flux density  $B$  at right angles to the plane of the coil X with time  $t$ .

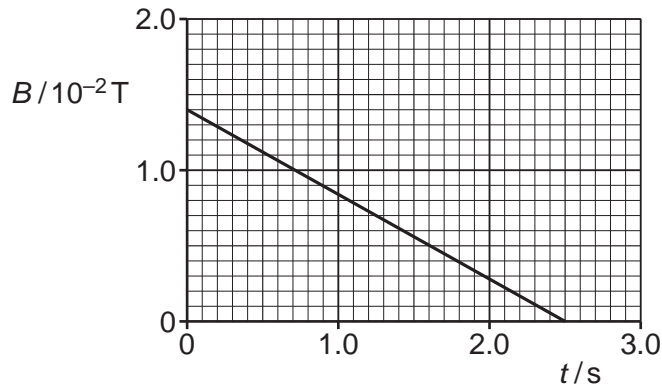

Fig. 3.2

The coil X has radius 3.2 cm and 180 turns.

(i) Explain why the induced e.m.f. across the ends of the coil has a constant value from  $t = 0 \text{ s}$  to  $t = 2.5 \text{ s}$ .

.....  
 .....  
 ..... [1]

- (ii) Calculate the magnitude of the induced e.m.f. across the ends of coil X from  $t = 0$  s to  $t = 2.5$  s.

e.m.f. = ..... V [3]

- (c) Fig. 3.3 shows a transformer circuit.

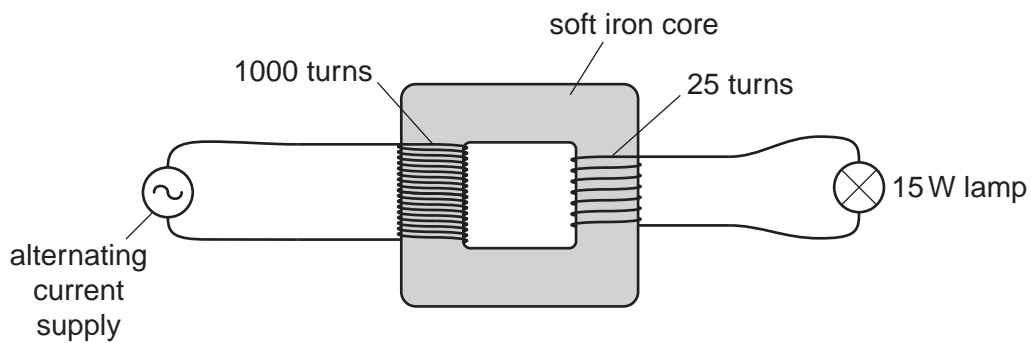

Fig. 3.3

The primary coil has 1000 turns and the secondary coil 25 turns. A lamp is connected to the output of the secondary coil. The potential difference across the lamp is 6.0V and the lamp dissipates 15W. The transformer has an efficiency of 100%.

- (i) Calculate the current in the primary coil.

current = ..... A [2]

- (ii) The alternating voltage supply is replaced by a battery. Explain why the p.d. across the lamp is zero some time after the battery is connected.

.....

.....

.....

.....

.....

..... [1]