

Density and Pressure

Question paper 3

Level	IGCSE(9-1)
Subject	Physics
Exam Board	Edexcel IGCSE
Module	Double Award (Paper 1P)
Topic	Solids, Liquids and Gases
Sub-Topic	Density and Pressure
Booklet	Question paper 3

Time Allowed: 50 minutes

Score: /41

Percentage: /100

Grade Boundaries:

A*	A	B	C	D	E	U
>85%	'75%	70%	60%	55%	50%	<50%

1 The LR5 is a specialist submarine for underwater rescues.

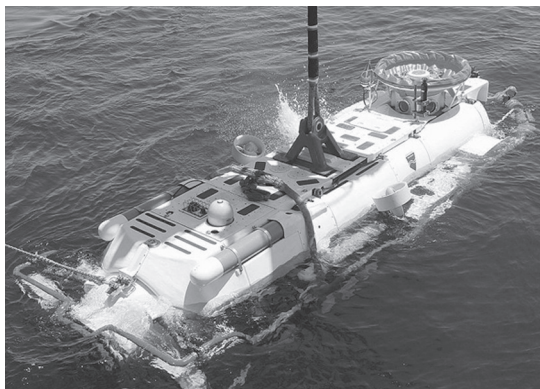

The average density of sea water is 1028 kg/m^3 .

(a) (i) State the equation linking pressure difference, depth, density and g . (1)

(ii) Calculate the increase in pressure as the LR5 descends from the surface to a depth of 700 m. (2)

increase in pressure = Pa

(iii) Atmospheric pressure is $1.0 \times 10^5 \text{ Pa}$.
Calculate the total pressure on the LR5 when it is at a depth of 700 m. (1)

total pressure = Pa

(b) On another descent, the LR5 experiences a total pressure of 41×10^5 Pa.

The entrance to the LR5 is through an access door which has an area of 3.1 m^2 .

(i) State the equation linking pressure, force and area. (1)

(ii) Calculate the force on the outside of the door. (3)

force = N

(c) The LR5 is tested in fresh water.

The density of fresh water is 1000 kg/m^3 .

Explain why the pressure on the submarine in the fresh water is less than the pressure in sea at the same depth. (1)

.....

.....

.....

(d) A student is given a sample of liquid labelled sea water.

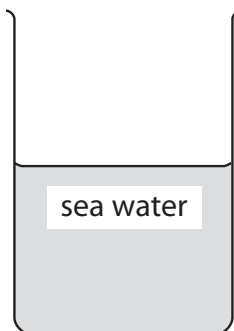

Describe an experiment that the student could carry out to find the density of the sample.

(5)

.....

.....

.....

.....

.....

.....

.....

.....

.....

.....

.....

.....

.....

.....

.....

.....

.....

.....

.....

.....

.....

.....

.....

(Total for Question 1 = 14 marks)

2 A student places a pile of coins on a table, as shown in photograph A.



Photograph A

There are 8 coins in the pile.

The weight of each coin is 0.036 N.

The area of each coin is 0.0013 m².

(a) (i) State the equation linking pressure, force and area.

(1)

(ii) Calculate the pressure on the table caused by the pile of coins.

(2)

Pressure = Pa

(b) The student then spreads the 8 coins out on the table as shown in photograph B.



Photograph B

(i) Describe how this affects the total force from the coins on the table.

(2)

.....

.....

.....

.....

.....

(ii) Explain how this affects the pressure on the table caused by the coins.

(2)

.....

.....

.....

.....

.....

(Total for Question 2 = 7 marks)

3 The diagram shows a can that produces whipped cream using gas at high pressure.

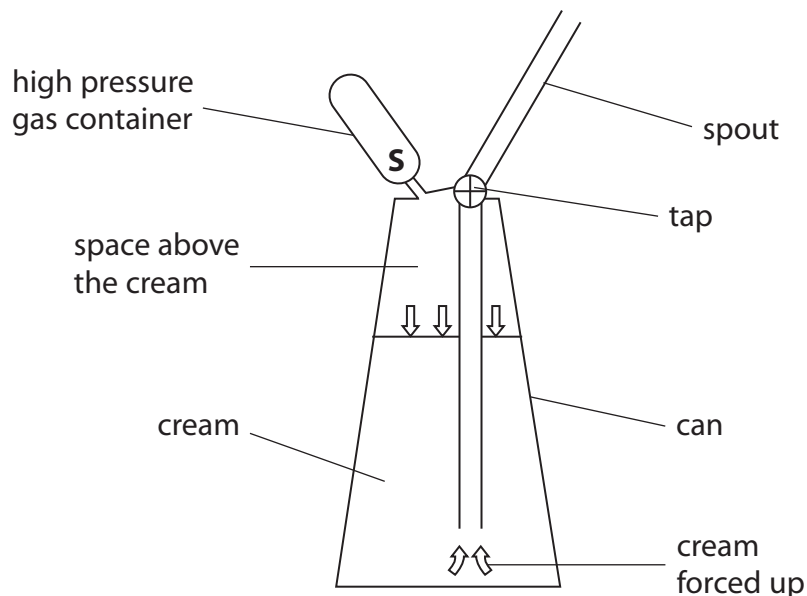

The volume of the high pressure gas container is 10 cm^3 .

The pressure of the gas is $10\,000 \text{ kPa}$.

When the seal at **S** is broken, the gas is released into the space above the cream.

The gas expands to a total volume of 270 cm^3 .

(a) Calculate the new pressure of the gas.

(2)

Pressure = kPa

(b) As the gas expands into the space above the cream, its temperature decreases.

Using ideas about molecules, explain how this affects the pressure of the gas.

(3)

.....

.....

.....

.....

.....

.....

.....

.....

.....

(c) Some of the gas molecules dissolve into the cream.

(i) Suggest how this affects the pressure of the gas in the space above the cream.

(2)

.....

.....

.....

.....

.....

(ii) When the tap is opened, the pressure of the gas forces the cream out of the spout.
The pressure outside the can is less than it is inside.

Suggest what happens to the dissolved gas as the cream leaves the can.

(1)

.....

.....

.....

.....

(Total for Question 3 = 8 marks)

4 Aneroid barometers are used to measure air pressure.

A student makes a model aneroid barometer as shown.

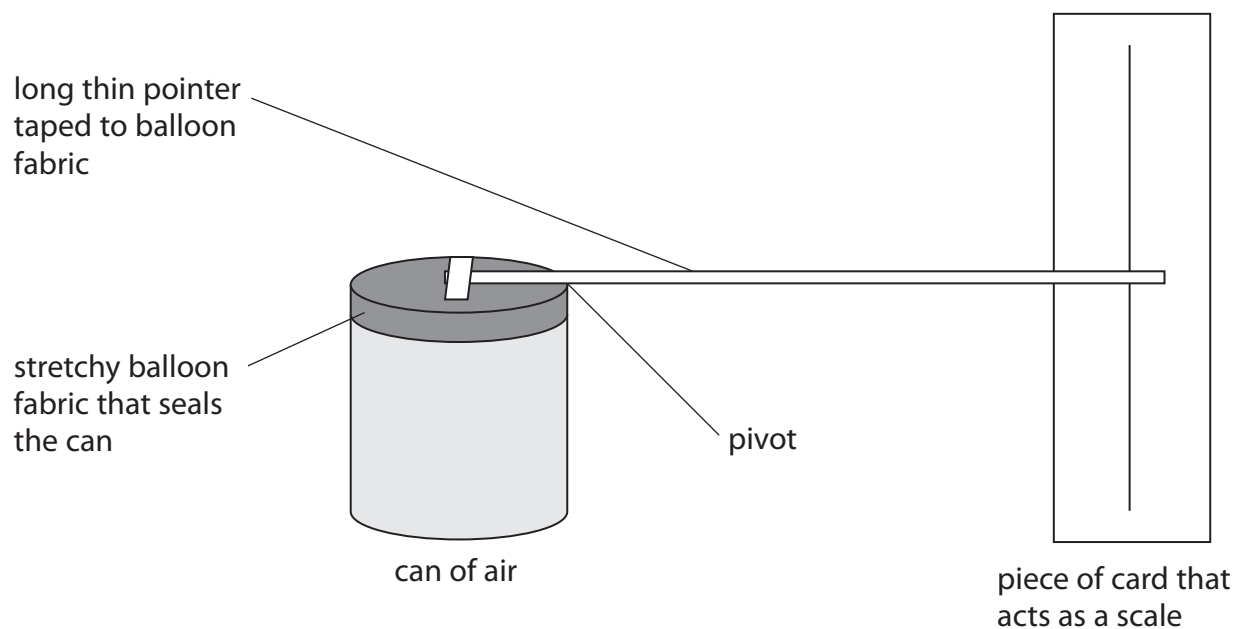

(a) (i) The balloon fabric is attached to the can to stop the air escaping.

Explain how the air inside the can causes a pressure on the balloon fabric.

(3)

.....

.....

.....

.....

.....

.....

- (ii) The balloon fabric is tight and flat.
The pointer is horizontal as shown.

Explain what happens to the different parts of the model when the atmospheric pressure increases. [You may assume that the temperature remains constant.]

(4)

.....

.....

.....

.....

.....

.....

.....

.....

.....

.....

.....

.....

.....

.....

.....

.....

.....

.....

.....

.....

.....

.....

- (iii) Suggest two ways that the model could be altered to increase its sensitivity to changes in atmospheric pressure.

(2)

1.....

.....

.....

.....

2.....

.....

.....

.....

(b) The student heats the air in her can by placing the can in a water bath.

(i) State how this affects the reading shown by the pointer.

(1)

.....

.....

(ii) Explain why this happens.

(2)

.....

.....

.....

.....

(Total for Question 4 = 12 marks)