

Group 2

Question Paper 2

Level	International A Level
Subject	Chemistry
Exam Board	CIE
Topic	Group 2
Sub-Topic	
Paper Type	Theory
Booklet	Question Paper 2

Time Allowed: 72 minutes

Score: /60

Percentage: /100

Grade Boundaries:

A*	A	B	C	D	E	U
>85%	77.5%	70%	62.5%	57.5%	45%	<45%

- 1 Calcium is the fifth most common element in the Earth’s crust. Calcium compounds occur in bones and teeth and also in many minerals.

Some reactions of calcium and its compounds are shown in the reaction scheme below.

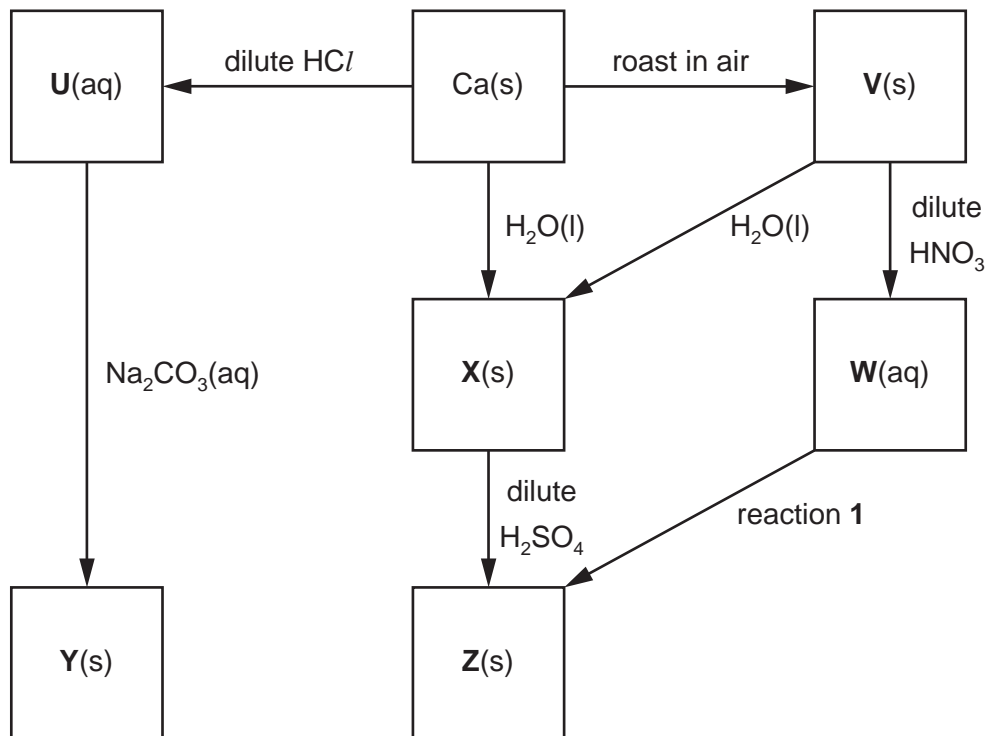

- (a) State the formula of **each** of the calcium compounds **U** to **Y**.

U

V

W

X

Y

[5]

- (b) Compound **Y** may be converted into compound **V**. Outline how this reaction would be carried out in a school or college laboratory using a small sample of **Y**.

.....

..... [1]

(c) (i) Construct balanced equations for the following reactions.

calcium to compound **U**

.....

compound **V** to compound **W**

.....

compound **U** to compound **Y**

.....

(ii) Construct a balanced equation for the effect of heat on solid compound **W**.

.....

[4]

(d) Suggest the formula of an aqueous reagent, other than an acid, for reaction 1.

.....

[1]

(e) What would be observed when **each** of the following reactions is carried out in a test-tube?

the formation of **X** from Ca(s)

.....

the formation of **X** from **V**

.....

[2]

[Total: 13]

2 Barium, proton number 56, is a Group II element which occurs in nature as the carbonate or sulfate.

The element was first isolated by Sir Humphry Davy in 1808.

Some reactions of barium and its compounds are shown in the reaction scheme below.

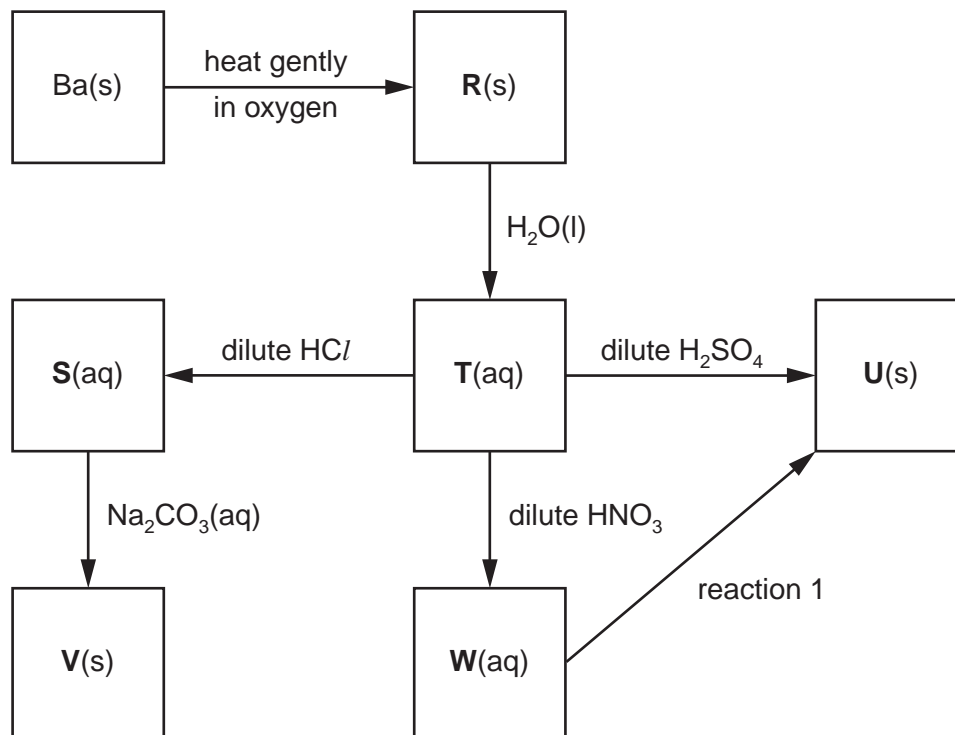

(a) State the formula of **each** of the barium compounds **R** to **W**.

R

S

T

U

V

W

[6]

(b) (i) Write balanced equations for the following reactions.

compound **T** to compound **W**

.....

the roasting of **V** in air

.....

- (ii) Suggest a gaseous reagent for the conversion of **T** into **V** and write a balanced equation for the reaction.

reagent

equation

[4]

- (c) Suggest the formula of an aqueous reagent, other than an acid, for reaction 1.

.....

[1]

When barium is heated strongly in oxygen, an oxide **X** is formed.
The oxide **X** contains 18.9% of oxygen by mass.

The oxide **X** reacts with dilute sulfuric acid in a 1:1 ratio.
Two products, one insoluble and one soluble, are formed.

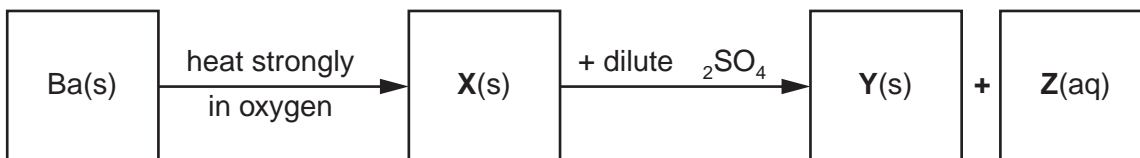

- (d) (Calculate the empirical formula of **X**.

- (ii) Suggest the identity of the solid **Y**.

.....

- (iii) Use your answers to (i) and (ii) to construct an equation for the reaction of **X** with H_2SO_4 .

..... [4]

[Total: 15]

- 3 (a) Write an equation representing the action of heat on calcium nitrate, $\text{Ca}(\text{NO}_3)_2$.

.....
[1]

- (b) Describe and explain the trend in the thermal stabilities of the nitrates of the Group II elements.

.....
.....
.....
.....
.....
[3]

- (c) Sodium carbonate is stable to heat, but heating lithium carbonate readily produces $\text{CO}_2(\text{g})$.

- (i) Suggest an equation for the action of heat on lithium carbonate.

.....

- (ii) Suggest a reason for the difference in reactivity of these two carbonates.

.....
.....

- (iii) Predict what you would see if a sample of lithium nitrate was heated. Explain your answer.

.....
.....
.....

[4]

[Total: 8]

- 4 (a) Describe **three** characteristic chemical properties of transition elements that are not shown by Group II elements.

.....

 [3]

- (b) When $\text{NH}_3(\text{aq})$ is added to a green solution containing $\text{Ni}^{2+}(\text{aq})$ ions, a grey-green precipitate is formed. This precipitate dissolves in an excess of $\text{NH}_3(\text{aq})$ to give a blue-violet solution.

Suggest an explanation for these observations, showing your reasoning and including equations for the reactions you describe.

.....

 [4]

- (c) Dimethylglyoxime, DMG, is a useful reagent for the quantitative estimation of nickel. It forms an insoluble salt with nickel ions according to the following equation.

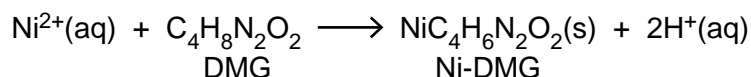

A small coin of mass 3.40g was dissolved in nitric acid and an excess of DMG was added. The precipitated Ni-DMG was filtered off, washed and dried. Its mass was 4.00g.

Calculate the % of nickel in the coin.

percentage of nickel =% [3]

[Total: 10]

(c) Calcium hydroxide, Ca(OH)_2 , is slightly soluble in water.

(i) Write an expression for K_{sp} for calcium hydroxide, and state its units.

$K_{\text{sp}} =$ units

(ii) 25.0cm^3 of a saturated solution of Ca(OH)_2 required 21.0cm^3 of 0.0500mol dm^{-3} HCl for complete neutralisation.

Calculate the $[\text{OH}^-(\text{aq})]$ and the $[\text{Ca}^{2+}(\text{aq})]$ in the saturated solution, and hence calculate a value for K_{sp} .

$[\text{OH}^-(\text{aq})] =$

$[\text{Ca}^{2+}(\text{aq})] =$

$K_{\text{sp}} =$

(iii) How would the solubility of Ca(OH)_2 in 0.1mol dm^{-3} NaOH compare with that in water?

Explain your answer.

.....

.....

[6]

[Total: 14]