



UNIVERSITY OF CAMBRIDGE INTERNATIONAL EXAMINATIONS  
International General Certificate of Secondary Education

CANDIDATE  
NAME

CENTRE  
NUMBER

--	--	--	--	--

CANDIDATE  
NUMBER

--	--	--	--	--

\* 8 1 7 8 1 4 2 5 5 6 \*

**MATHEMATICS**

**0580/43**

Paper 4 (Extended)

**October/November 2011**

**2 hours 30 minutes**

Candidates answer on the Question Paper.

Additional Materials:

Electronic calculator  
Mathematical tables (optional)

Geometrical instruments  
Tracing paper (optional)

**READ THESE INSTRUCTIONS FIRST**

Write your Centre number, candidate number and name on all the work you hand in.

Write in dark blue or black pen.

You may use a pencil for any diagrams or graphs.

Do not use staples, paper clips, highlighters, glue or correction fluid.

**DO NOT WRITE IN ANY BARCODES.**

Answer **all** questions.

If working is needed for any question it must be shown below that question.

Electronic calculators should be used.

If the degree of accuracy is not specified in the question, and if the answer is not exact, give the answer to three significant figures. Give answers in degrees to one decimal place.

For  $\pi$  use either your calculator value or 3.142.

At the end of the examination, fasten all your work securely together.

The number of marks is given in brackets [ ] at the end of each question or part question.

The total of the marks for this paper is 130.

This document consists of **20** printed pages.



1

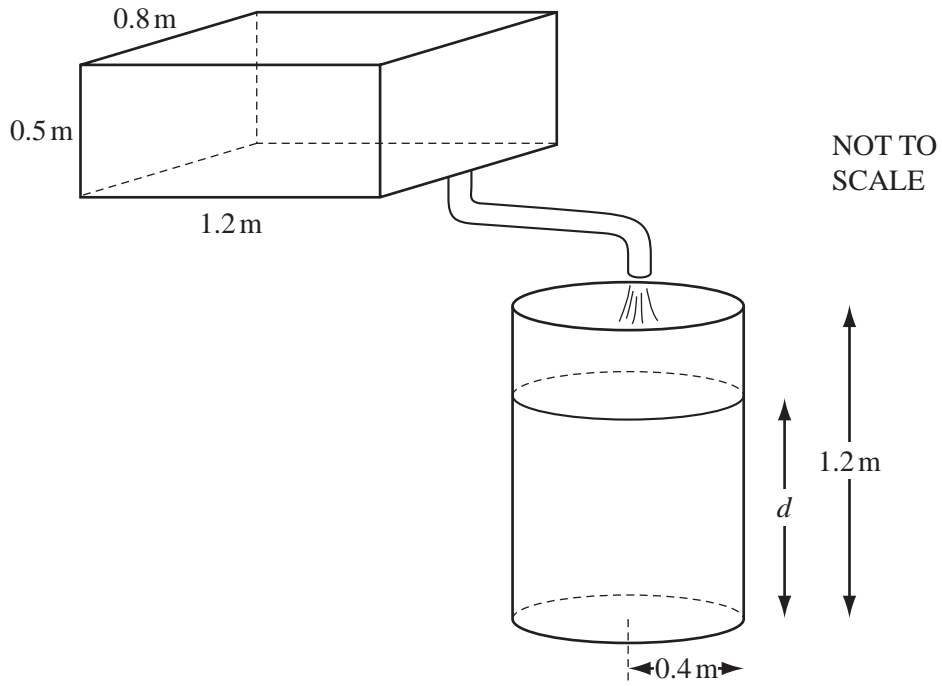

For  
Examiner's  
Use

A rectangular tank measures 1.2 m by 0.8 m by 0.5 m.

- (a) Water flows from the full tank into a cylinder at a rate of  $0.3 \text{ m}^3/\text{min}$ .

Calculate the time it takes for the full tank to empty.  
Give your answer in minutes and seconds.

Answer(a) ..... min ..... s [3]

- (b) The radius of the cylinder is 0.4 m.

Calculate the depth of water,  $d$ , when all the water from the rectangular tank is in the cylinder.

For  
Examiner's  
Use

Answer(b)  $d =$  ..... m [3]

- (c) The cylinder has a height of 1.2 m and is open at the top.  
The inside surface is painted at a cost of \$2.30 per  $\text{m}^2$ .

Calculate the cost of painting the inside surface.

Answer(c) \$ ..... [4]

---

- 2 (a) Complete the table of values for  $y = 2^x$ .

$x$	-2	-1	0	1	2	3
$y$	0.25		1	2		8

[2]

- (b) On the grid, draw the graph of  $y = 2^x$  for  $-2 \leq x \leq 3$ .

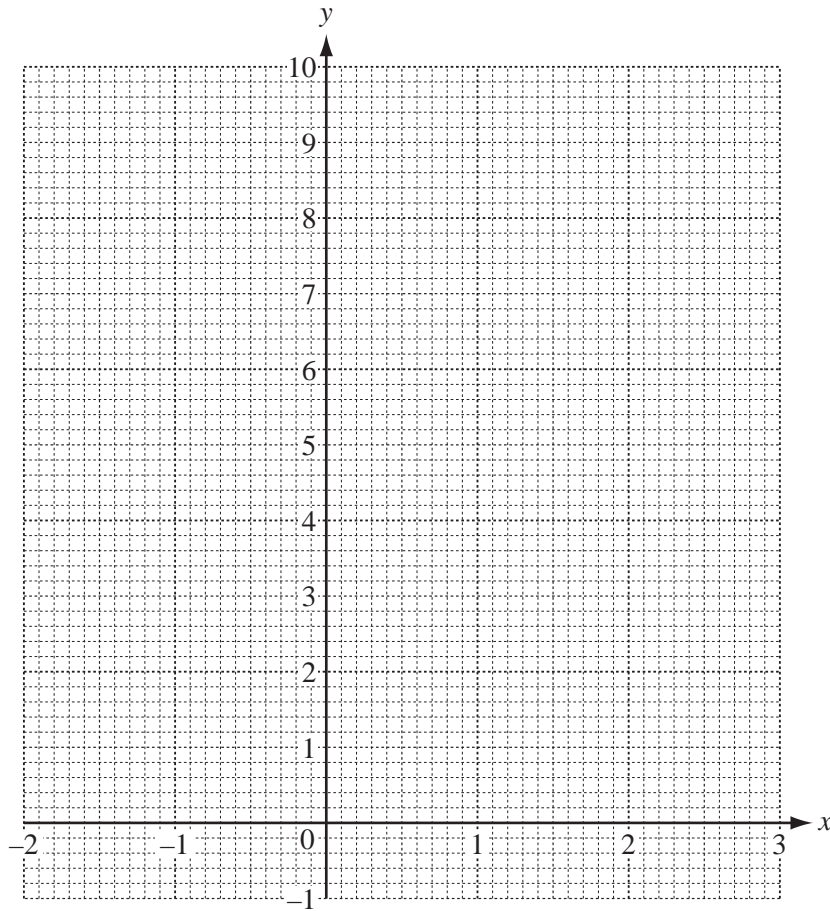

[3]

For  
Examiner's  
Use

(c) (i) On the grid, draw the straight line which passes through the points (0, 2) and (3, 8). [1]

(ii) The equation of this line is  $y = mx + 2$ .

Show that the value of  $m$  is 2.

*Answer(c)(ii)*

(iii) One answer to the equation  $2^x = 2x + 2$  is  $x = 3$ . [1]

Use your graph to find the other answer.

*Answer(c)(iii)*  $x =$  ..... [1]

(d) Draw the tangent to the curve at the point where  $x = 1$ .

Use this tangent to calculate an estimate of the gradient of  $y = 2^x$  when  $x = 1$ .

*Answer(d)* ..... [3]

3 (a)

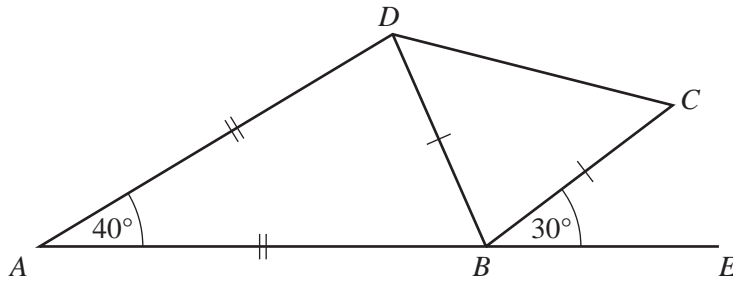
NOT TO  
SCALEFor  
Examiner's  
Use

$ABCD$  is a quadrilateral with angle  $BAD = 40^\circ$ .  
 $AB$  is extended to  $E$  and angle  $EBC = 30^\circ$ .  
 $AB = AD$  and  $BD = BC$ .

(i) Calculate angle  $BCD$ .

Answer(a)(i) Angle  $BCD = \dots\dots\dots$  [3]

(ii) Give a reason why  $DC$  is not parallel to  $AE$ .

Answer(a)(ii)  $\dots\dots\dots$  [1]

(b) A regular polygon has  $n$  sides.

Each exterior angle is  $\frac{5n}{2}$  degrees.

Find the value of  $n$ .

Answer(b)  $n = \dots\dots\dots$  [3]

(c)

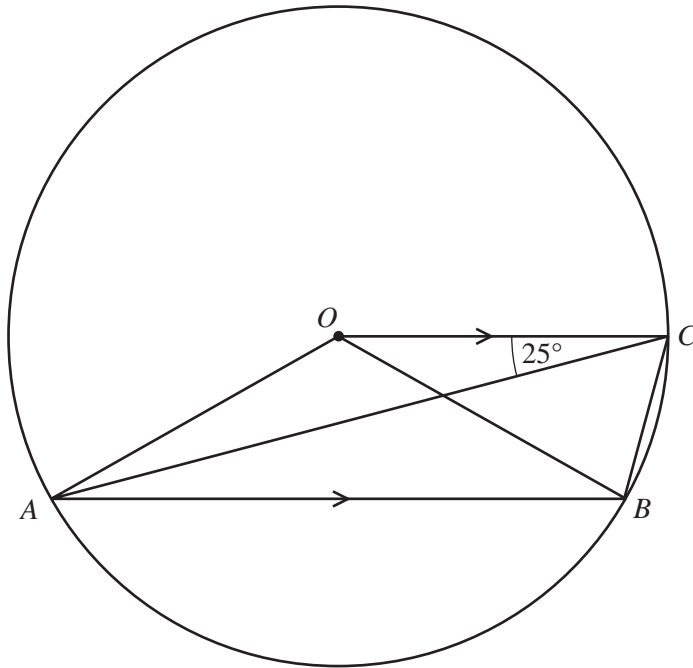
NOT TO  
SCALE

The diagram shows a circle centre  $O$ .  
 $A$ ,  $B$  and  $C$  are points on the circumference.  
 $OC$  is parallel to  $AB$ .  
 Angle  $OCA = 25^\circ$ .

Calculate angle  $OBC$ .

Answer(c) Angle  $OBC = \dots\dots\dots$  [3]

For  
Examiner's  
Use

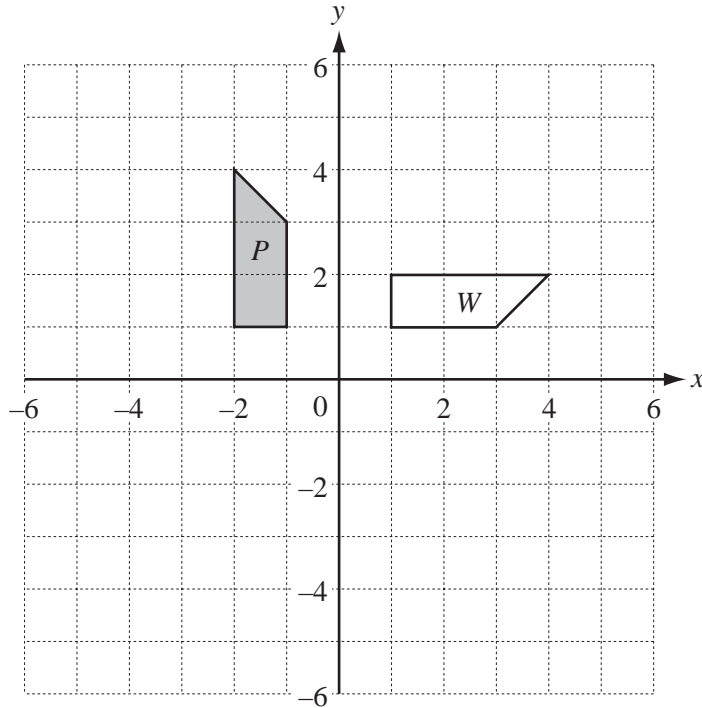

(a) Draw the reflection of shape *P* in the line  $y = x$ . [2]

(b) Draw the translation of shape *P* by the vector  $\begin{pmatrix} -2 \\ 1 \end{pmatrix}$ . [2]

(c) (i) Describe fully the **single** transformation that maps shape *P* onto shape *W*.

Answer(c)(i) ..... [3]

(ii) Find the 2 by 2 matrix which represents this transformation.

Answer(c)(ii)  $\begin{pmatrix} & \\ & \end{pmatrix}$  [2]

(d) Describe fully the **single** transformation represented by the matrix  $\begin{pmatrix} 1 & 0 \\ 0 & 2 \end{pmatrix}$ .

Answer(d) ..... [3]



- 5 (a) The cost of a bottle of juice is 5 cents more than the cost of a bottle of water.  
Mohini buys 3 bottles of water and 6 bottles of juice.  
The total cost is \$5.25.

Find the cost of a bottle of water.  
Give your answer in cents.

*Answer(a)* ..... cents [4]

- (b) The cost of a biscuit is  $x$  cents.  
The cost of a cake is  $(x + 3)$  cents.  
The number of biscuits Roshni can buy for 72 cents is 2 more than the number of cakes she can buy for 72 cents.

- (i) Show that  $x^2 + 3x - 108 = 0$ .

*Answer(b)(i)*

[3]

- (ii) Solve the equation  $x^2 + 3x - 108 = 0$ .

*Answer(b)(ii)*  $x =$  ..... or  $x =$  ..... [3]

- (iii) Find the total cost of 2 biscuits and 1 cake.

*Answer(b)(iii)* ..... cents [1]

*For  
Examiner's  
Use*

6

For  
Examiner's  
Use

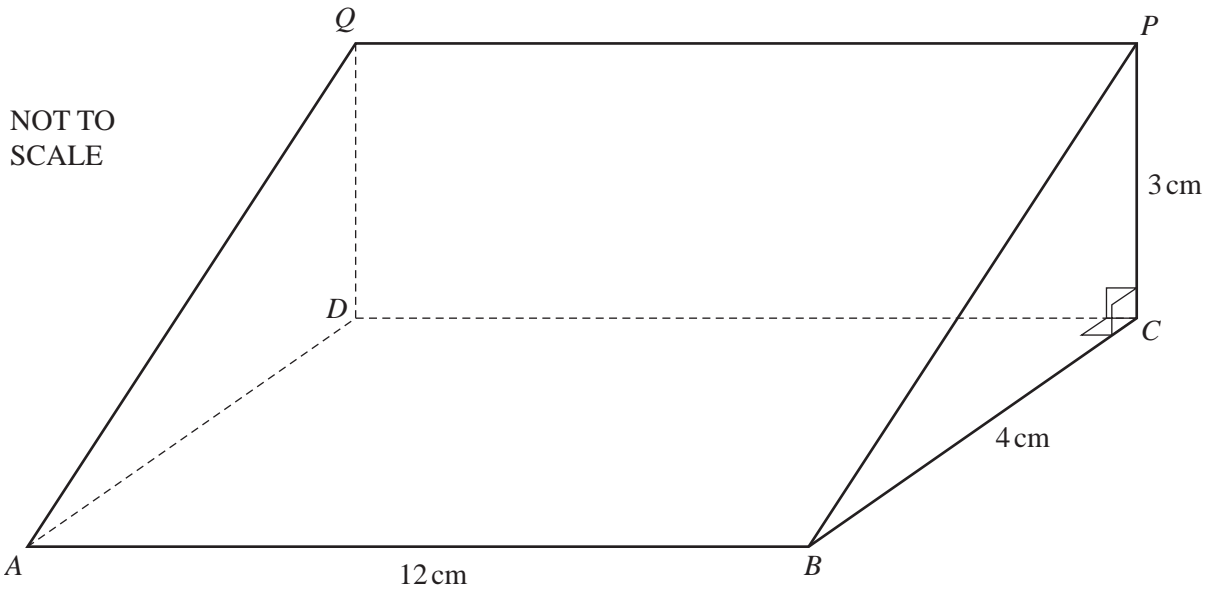

The diagram shows a triangular prism of length 12 cm.

The rectangle  $ABCD$  is horizontal and the rectangle  $DCPQ$  is vertical.

The cross-section is triangle  $PBC$  in which angle  $BCP = 90^\circ$ ,  $BC = 4$  cm and  $CP = 3$  cm.

(a) (i) Calculate the length of  $AP$ .

Answer(a)(i)  $AP =$  ..... cm [3]

(ii) Calculate the angle of elevation of  $P$  from  $A$ .

Answer(a)(ii) ..... [2]

(b) (i) Calculate angle  $PBC$ .

For  
Examiner's  
Use

*Answer(b)(i)* Angle  $PBC = \dots\dots\dots$  [2]

(ii)  $X$  is on  $BP$  so that angle  $BXC = 120^\circ$ .

Calculate the length of  $XC$ .

*Answer(b)(ii)*  $XC = \dots\dots\dots$  cm [3]

---

- 7 The times,  $t$  minutes, taken for 200 students to cycle one kilometre are shown in the table.

Time ( $t$ minutes)	$0 < t \leq 2$	$2 < t \leq 3$	$3 < t \leq 4$	$4 < t \leq 8$
Frequency	24	68	72	36

- (a) Write down the class interval that contains the median.

*Answer(a)* ..... [1]

- (b) Calculate an estimate of the mean.  
Show all your working.

*Answer(b)* ..... min [4]

*For  
Examiner's  
Use*

(c) (i) Use the information in the table opposite to complete the cumulative frequency table.

Time ( $t$ minutes)	$t \leq 2$	$t \leq 3$	$t \leq 4$	$t \leq 8$
Cumulative frequency	24			200

[1]

(ii) On the grid, draw a cumulative frequency diagram.

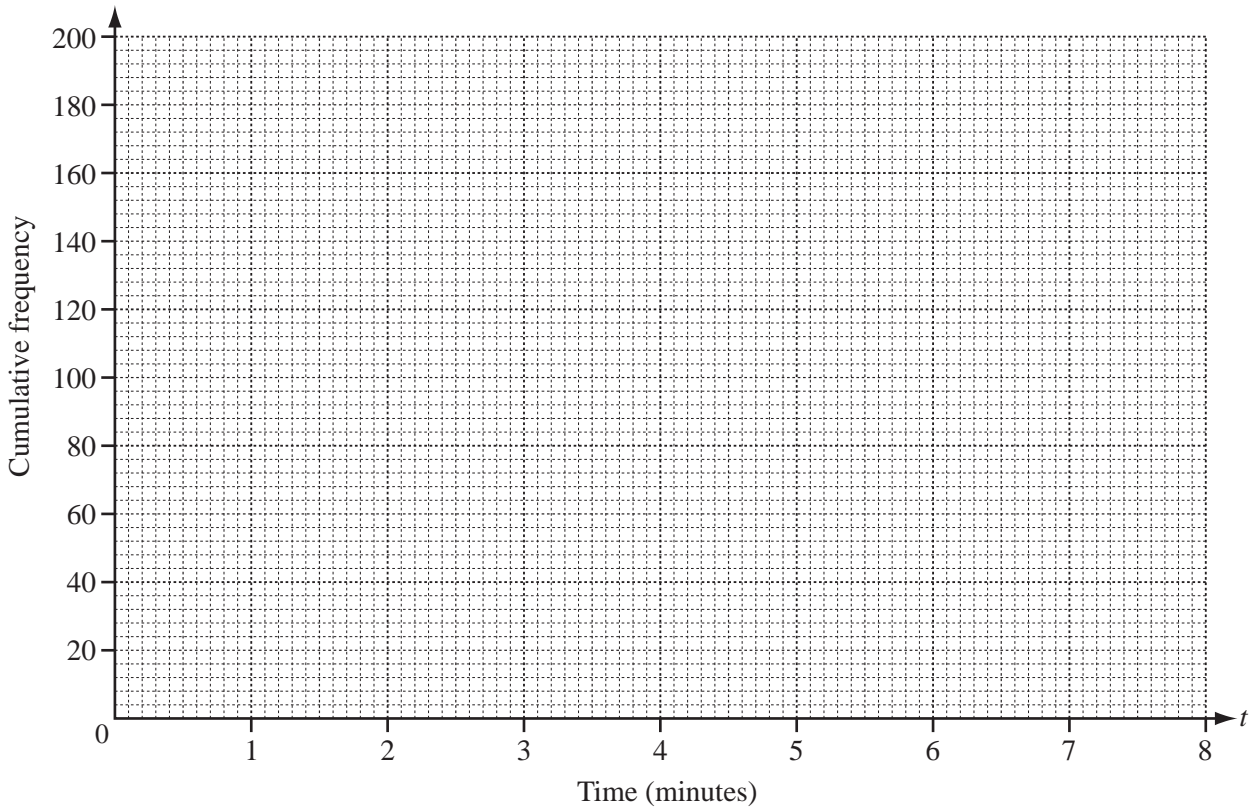

[3]

(iii) Use your diagram to find the median, the lower quartile and the inter-quartile range.

Answer(c)(iii) Median = ..... min

Lower quartile = ..... min

Inter-quartile range = ..... min [3]

For  
Examiner's  
Use

8  $f(x) = x^2 + x - 1$        $g(x) = 1 - 2x$        $h(x) = 3^x$

(a) Find the value of  $hg(-2)$ .

Answer(a) ..... [2]

(b) Find  $g^{-1}(x)$ .

Answer(b)  $g^{-1}(x) =$  ..... [2]

(c) Solve the equation  $f(x) = 0$ .

Show all your working and give your answers correct to 2 decimal places.

Answer(c)  $x =$  ..... or  $x =$  ..... [4]

(d) Find  $fg(x)$ .

Give your answer in its simplest form.

Answer(d)  $fg(x) =$  ..... [3]

(e) Solve the equation  $h^{-1}(x) = 2$ .

Answer(e)  $x =$  ..... [1]

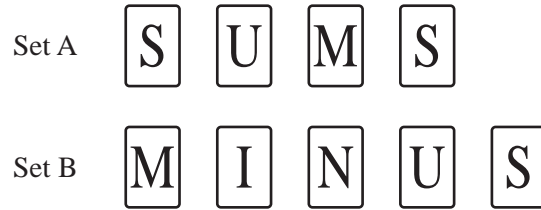

The diagram shows two sets of cards.

(a) One card is chosen at random from Set A and replaced.

(i) Write down the probability that the card chosen shows the letter M.

Answer(a)(i) ..... [1]

(ii) If this is carried out 100 times, write down the expected number of times the card chosen shows the letter M.

Answer(a)(ii) ..... [1]

(b) Two cards are chosen at random, **without** replacement, from Set A.

Find the probability that both cards show the letter S.

Answer(b) ..... [2]

(c) One card is chosen at random from Set A and one card is chosen at random from Set B.

Find the probability that exactly one of the two cards shows the letter U.

Answer(c) ..... [3]

(d) A card is chosen at random, **without** replacement, from Set B until the letter shown is either I or U.

Find the probability that this does not happen until the 4th card is chosen.

Answer(d) ..... [2]

10 Hassan stores books in large boxes and small boxes.  
Each large box holds 20 books and each small box holds 10 books.  
He has  $x$  large boxes and  $y$  small boxes.

(a) Hassan must store at least 200 books.

Show that  $2x + y \geq 20$ .

Answer(a)

[1]

(b) Hassan must not use more than 15 boxes.

He must use at least 3 small boxes.

The number of small boxes must be less than or equal to the number of large boxes.

Write down three inequalities to show this information.

Answer(b) .....

.....

..... [3]

(c) On the grid, show the information in **part (a)** and **part (b)** by drawing four straight lines and shading the **unwanted** regions.

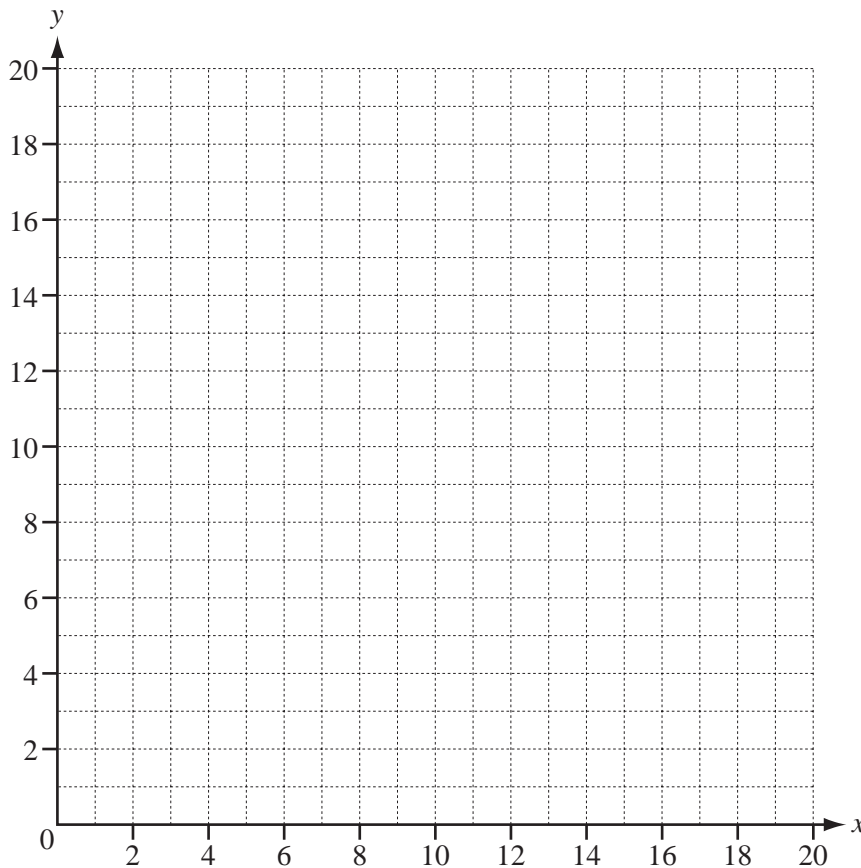

[6]



(d) A large box costs \$5 and a small box costs \$2.

(i) Find the least possible total cost of the boxes.

*Answer(d)(i)* \$ ..... [1]

(ii) Find the number of large boxes and the number of small boxes which give this least possible cost.

*Answer(d)(ii)* Number of large boxes = .....

Number of small boxes = ..... [2]

---

**Question 11 is printed on the next page.**

*For  
Examiner's  
Use*

11 (a)

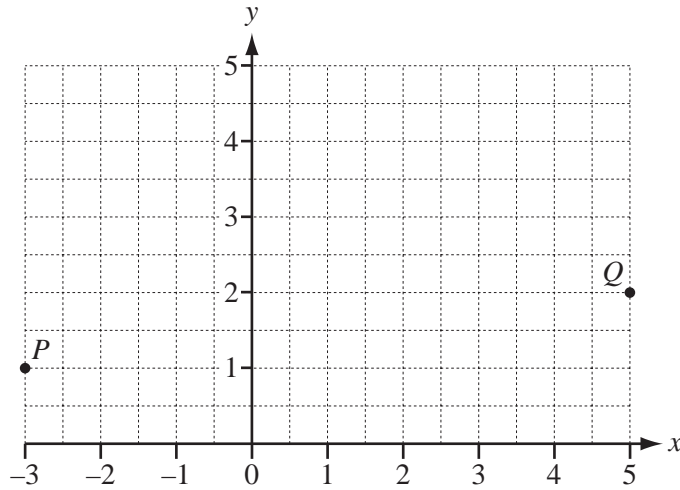

The points  $P$  and  $Q$  have co-ordinates  $(-3, 1)$  and  $(5, 2)$ .

(i) Write  $\vec{PQ}$  as a column vector.

$$\text{Answer(a)(i)} \vec{PQ} = \begin{pmatrix} \phantom{0} \\ \phantom{0} \end{pmatrix} \quad [1]$$

(ii)  $\vec{QR} = 2 \begin{pmatrix} -1 \\ 1 \end{pmatrix}$

Mark the point  $R$  on the grid.

[1]

(iii) Write down the position vector of the point  $P$ .

$$\text{Answer(a)(iii)} \begin{pmatrix} \phantom{0} \\ \phantom{0} \end{pmatrix} \quad [1]$$

(b)

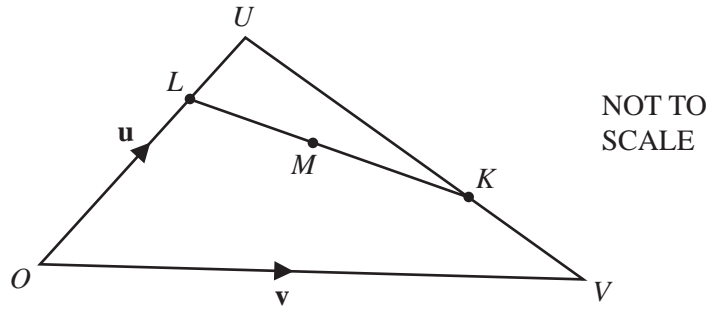
For  
Examiner's  
Use

In the diagram,  $\vec{OU} = \mathbf{u}$  and  $\vec{OV} = \mathbf{v}$ .

$K$  is on  $UV$  so that  $\vec{UK} = \frac{2}{3} \vec{UV}$  and  $L$  is on  $OU$  so that  $\vec{OL} = \frac{3}{4} \vec{OU}$ .

$M$  is the midpoint of  $KL$ .

Find the following in terms of  $\mathbf{u}$  and  $\mathbf{v}$ , giving your answers in their simplest form.

(i)  $\vec{LK}$

Answer(b)(i)  $\vec{LK} = \dots\dots\dots$  [4]

(ii)  $\vec{OM}$

Answer(b)(ii)  $\vec{OM} = \dots\dots\dots$  [2]

Question 12 is printed on the next page.

12 (a) The  $n$ th term of a sequence is  $n(n+1)$ .

(i) Write the two missing terms in the spaces. 2, 6, ..... , 20, ..... [2]

(ii) Write down an expression in terms of  $n$  for the  $(n + 1)$ th term.

Answer(a)(ii) ..... [1]

(iii) The difference between the  $n$ th term and the  $(n + 1)$ th term is  $pn + q$ .

Find the values of  $p$  and  $q$ .

Answer(a)(iii)  $p =$  .....

$q =$  ..... [2]

(iv) Find the positions of the two consecutive terms which have a difference of 140.

Answer(a)(iv) ..... and ..... [2]

(b) A sequence  $u_1, u_2, u_3, u_4, \dots$  is given by the following rules.

$u_1 = 2, \quad u_2 = 3 \quad \text{and} \quad u_n = 2u_{n-2} + u_{n-1} \quad \text{for } n \geq 3.$

For example, the third term is  $u_3$  and  $u_3 = 2u_1 + u_2 = 2 \times 2 + 3 = 7.$

So, the sequence is 2, 3, 7,  $u_4, u_5, \dots$

(i) Show that  $u_4 = 13.$

Answer(b)(i) ..... [1]

(ii) Find the value of  $u_5 .$

Answer(b)(ii)  $u_5 =$  ..... [1]

(iii) Two consecutive terms of the sequence are 3413 and 6827 .

Find the term before and the term after these two given terms.

Answer(b)(iii) ..... , 3413, 6827, ..... [2]

Permission to reproduce items where third-party owned material protected by copyright is included has been sought and cleared where possible. Every reasonable effort has been made by the publisher (UCLES) to trace copyright holders, but if any items requiring clearance have unwittingly been included, the publisher will be pleased to make amends at the earliest possible opportunity.

University of Cambridge International Examinations is part of the Cambridge Assessment Group. Cambridge Assessment is the brand name of University of Cambridge Local Examinations Syndicate (UCLES), which is itself a department of the University of Cambridge.