

Friday 09 October 2020 – Morning

A Level Physics A

H556/01 Modelling physics

Time allowed: 2 hours 15 minutes



You must have:

- the Data, Formulae and Relationships Booklet

You can use:

- a scientific or graphical calculator
- a ruler (cm/mm)



Please write clearly in black ink. **Do not write in the barcodes.**

Centre number

--	--	--	--	--

Candidate number

--	--	--	--

First name(s)

Last name

INSTRUCTIONS

- Use black ink. You can use an HB pencil, but only for graphs and diagrams.
- Write your answer to each question in the space provided. If you need extra space use the lined pages at the end of this booklet. The question numbers must be clearly shown.
- Answer **all** the questions.
- Where appropriate, your answer should be supported with working. Marks might be given for using a correct method, even if your answer is wrong.

INFORMATION

- The total mark for this paper is **100**.
- The marks for each question are shown in brackets [].
- Quality of extended response will be assessed in questions marked with an asterisk (*).
- This document has **32** pages.

ADVICE

- Read each question carefully before you start your answer.

2
SECTION A

You should spend a maximum of 30 minutes on this section.

Write your answer to each question in the box provided.

Answer **all** the questions.

- 1 An athlete is running at a speed of about 5 m s^{-1} .

What is a reasonable estimate for the kinetic energy of this athlete?

- A 12 J
- B 100 J
- C 900 J
- D 800 000 J

Your answer

[1]

- 2 Which pair of quantities have the same S.I. base units?

- A force, strain
- B force, stress
- C pressure, stress
- D strain, upthrust

Your answer

[1]

- 3 A tennis ball is hit with a racket. The force applied by the racket on the ball is F . The ball has a vertical path through the air.

Which statement is correct when the ball is at its **maximum** height?

- A The ball has a downward acceleration.
- B The force acting on the ball is F .
- C The ball experiences greatest drag.
- D The weight of the ball is equal to the drag.

Your answer

[1]

- 4 An oscillator is forced to oscillate at different frequencies.
The graph of amplitude A against driving frequency f for this oscillator is shown.

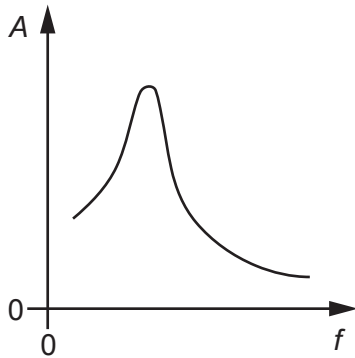

The damping on the oscillator is now **decreased**.

Which of the following statements is/are correct?

- 1 The amplitude of the oscillations at any frequency decreases.
- 2 The maximum amplitude occurs at a lower frequency.
- 3 The peak on the graph becomes thinner.

- A** Only 1
B Only 2
C Only 3
D 1, 2 and 3

Your answer

[1]

- 5 The gravitational force between two point-mass objects **X** and **Y** is F_1 .

The mass of **X** increases and the distance between **X** and **Y** is halved.

Which statement about the new gravitational force F_2 between these two objects is correct?

- A** $0 < F_2 < 0.25F_1$
B $F_2 > 4F_1$
C $F_2 = F_1$
D $2F_1 < F_2 < 4F_1$

Your answer

[1]

- 6 The diagram below shows two energy levels for the electron in the hydrogen atom.

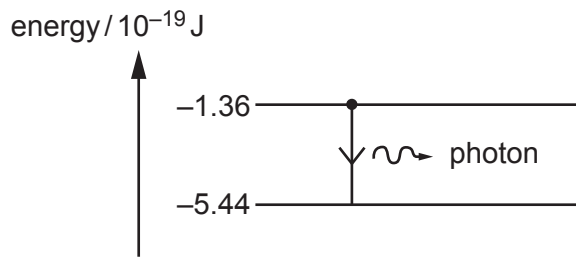

The electron makes the transition shown by the arrow.

What is the wavelength of the photon emitted?

- A 293 nm
- B 366 nm
- C 488 nm
- D 1460 nm

Your answer

[1]

- 7 Recent analysis of the data collected from the Hubble and Gaia telescopes gave the Hubble constant a value of $73.5 \text{ km s}^{-1} \text{ Mpc}^{-1}$.

What is this value, written to 2 significant figures, in s^{-1} ?

- A $2.4 \times 10^{-21} \text{ s}^{-1}$
- B $2.4 \times 10^{-18} \text{ s}^{-1}$
- C $2.4 \times 10^{-12} \text{ s}^{-1}$
- D $2.4 \times 10^{21} \text{ s}^{-1}$

Your answer

[1]

8 A wooden block is **stationary** on a ramp.

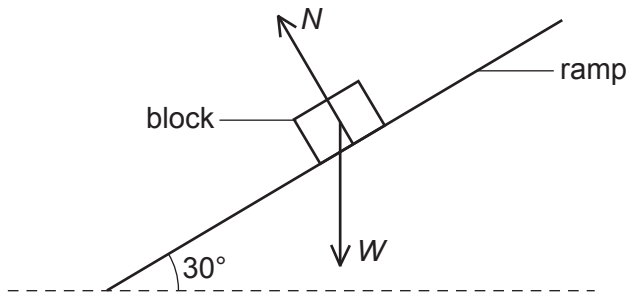

The diagram is **not** drawn to scale.

The block has weight W . The normal contact force on the block is N . The frictional force F on the block is not shown on the diagram.

Which triangle of forces diagram is correct?

- A
- B
- C
- D

Your answer

[1]

- 9 Laser light of wavelength of 640 nm is incident normally at a diffraction grating. The separation between adjacent lines (slits) is 3.3×10^{-6} m.

What is the **total** number of bright spots that can be observed in the diffraction pattern?

- A 5
- B 6
- C 10
- D 11

Your answer

[1]

- 10 A spring is stretched by hanging on it a variable mass m . The mass m is always at rest. The spring obeys Hooke's law.

What is the relationship between the elastic potential energy E in the spring and the mass m ?

- A $E \propto m^{-1}$
- B $E \propto m^{-2}$
- C $E \propto m$
- D $E \propto m^2$

Your answer

[1]

- 11 In astronomy, distance can be measured in different units.

Which one of the following distances is the **largest**?

- A 4.22×10^{16} m
- B 1.91 pc
- C 3.42 ly
- D 593 AU

Your answer

[1]

12 An oscillator is executing simple harmonic motion.

Which graph of kinetic energy KE against displacement x is correct for this oscillator?

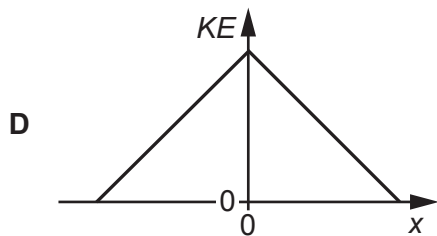
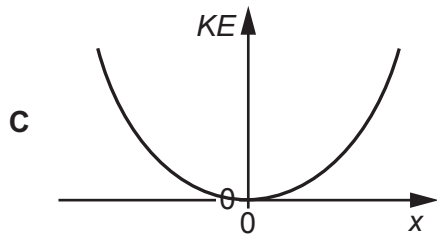
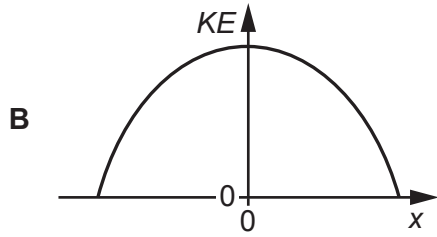
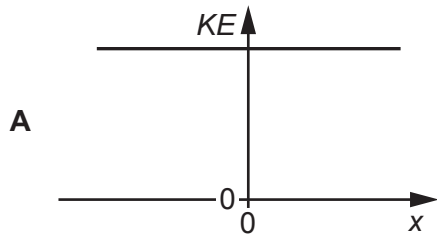

Your answer

[1]

- 13 The Young modulus E of a metal can be determined using the expression $E = \frac{4F}{\varepsilon\pi d^2}$, where F is the tension in the wire, d is the diameter of the wire and ε is the strain of the wire.

Here is some data.

Quantity	Percentage uncertainty
F	5.3
ε	1.2
d	1.0

What is the percentage uncertainty in the calculated value of E ?

- A 2.1%
 B 6.4%
 C 7.5%
 D 8.5%

Your answer

[1]

- 14 The velocity v against time t graphs for four objects **A**, **B**, **C** and **D** are shown below.

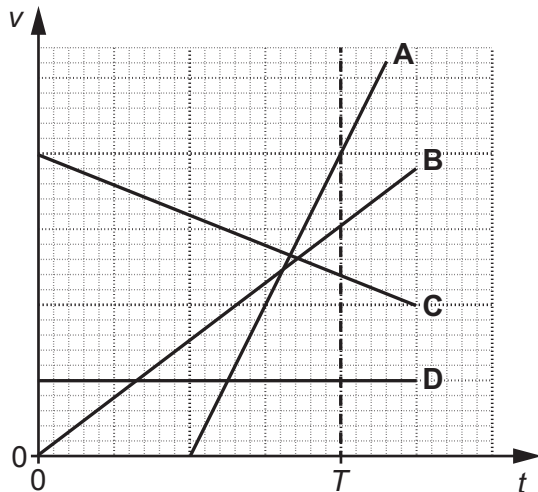

Which object travels the greatest distance between $t = 0$ and $t = T$?

Your answer

[1]

- 15 The kinetic theory of matter is a model used to describe the behaviour of particles (atoms or molecules) in an ideal gas. There are a number of assumptions made in the kinetic model for an ideal gas.

Which one of the following assumptions is **not** correct?

- A The collisions of particles with each other and the container walls are perfectly inelastic.
- B The electrostatic forces between particles are negligible except during collisions.
- C The particles occupy negligible volume compared to the volume of the gas.
- D There are a large number of particles in random motion.

Your answer

[1]

10
SECTION B

Answer **all** the questions.

- 16 A truck pulls a car up a slope at a **constant** speed.
The truck and the car are joined with a steel tow bar, as shown in the diagram.

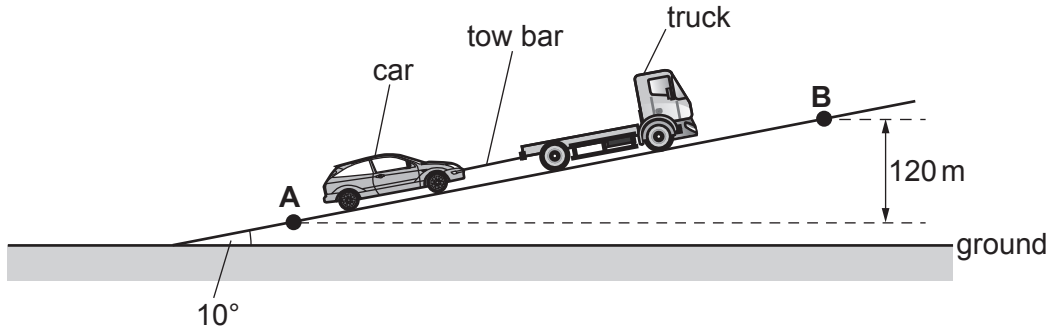

The diagram is **not** drawn to scale.

The slope is 10° to the horizontal ground.

The mass of the car is 1100 kg.

The car travels from **A** to **B**. The vertical distance between **A** and **B** is 120 m.

- (a) There are four forces acting on the **car** travelling up the slope.

Complete the free-body diagram below for the car and label the missing forces.

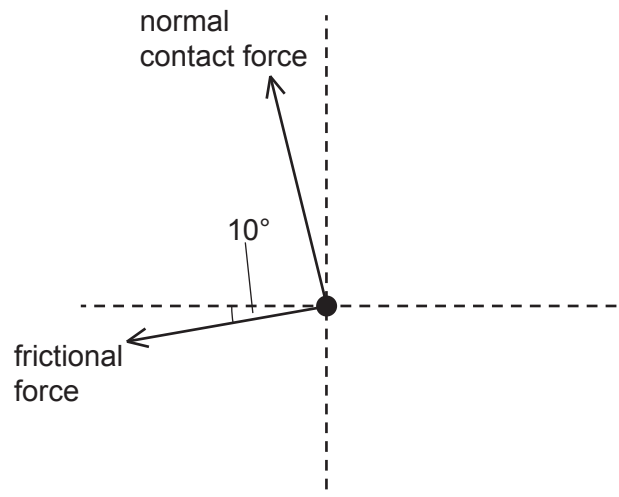

[2]

(b) Show that the component of the weight of the car W_s acting down the slope is about 1900 N.

[1]

(c) The total frictional force acting on the car as it travels up the slope is 300 N.

Calculate the force provided by the tow bar on the car.

force = N [1]

(d) Calculate the work done by the force provided by the tow bar as the car travels from **A** to **B**.

work done = J [3]

12

- (e) The steel tow bar used to pull the car has length 0.50 m and diameter 1.2×10^{-2} m. The Young modulus of steel is 2.0×10^{11} Pa.

Calculate the extension x of the tow bar as the car travels up the slope.

$x = \dots\dots\dots$ m [3]

17 (a) A heater is used to heat water in a beaker.

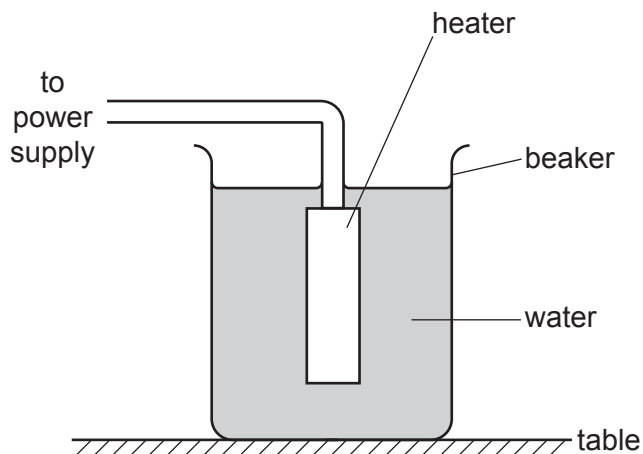

(i) Before switching on, the metal heater and the water are both at room temperature.

Describe the motion of the atoms of the metal heater and of the water molecules.

.....

.....

.....

.....

.....

.....

.....

..... [3]

(ii) The heater is now switched on.
 The power of the heater is 200 W.
 The mass of the water in the beaker is 500 g.
 It takes 10.0 minutes to increase the temperature of the water in the beaker from 20 °C to 60 °C.

Calculate the energy transferred from the water to the **beaker and the surroundings**.

- specific heat capacity of water = 4200 J kg⁻¹ K⁻¹

energy transferred = J [3]

(b)* A student is carrying out an experiment to determine the specific latent heat of fusion L_f of ice. The student has two sets of apparatus next to each other on the laboratory bench, as shown in Fig. 17.1 and Fig. 17.2.

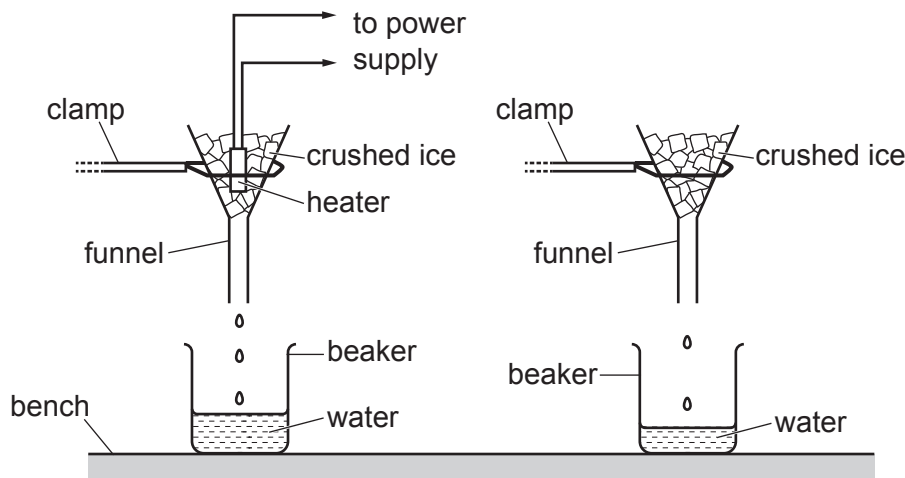

Fig. 17.1

Fig. 17.2

Both funnels are identical and have the same mass of crushed ice at 0°C .

The current in the heater is 5.0A and the potential difference across it is 12V .

Fig. 17.3 shows the variation of mass of water m collected in each beaker with time t .

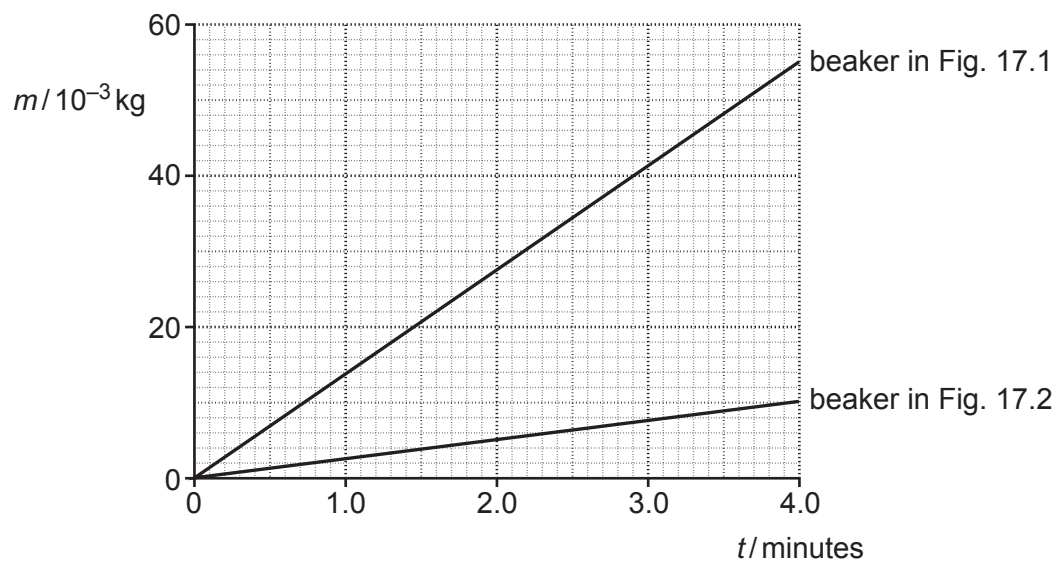
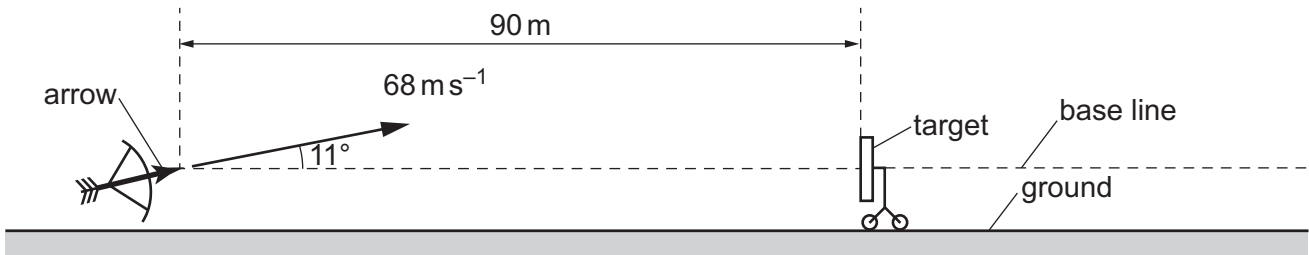

Fig. 17.3

18 An archer fires an arrow towards a target as shown below.



The diagram is **not** drawn to scale.

The centre of the target is at the same height as the initial position of the arrow.

The target is a distance of 90 m from the arrow.

The arrow has an initial velocity of 68 m s^{-1} and is fired at an angle of 11° to the horizontal.

Air resistance has negligible effect on the motion of the arrow.

- (a) Describe how the kinetic energy of the arrow changes during its journey from when it is fired until it reaches its maximum height.

.....

.....

.....

..... [2]

- (b) Show that the time taken for the arrow to reach its maximum height is about 1.3 s .

[2]

(c) The arrow misses the target.

Calculate the horizontal distance, measured along the base line, by which the arrow misses the target.

horizontal distance = m [3]

(d) The arrow is now fired horizontally at 68 m s^{-1} into the target at very close range.

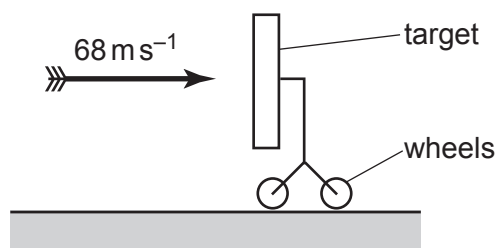

The arrow sticks into the target. The collision between the arrow and the target is inelastic.

(i) Explain what is meant by an **inelastic collision**.

.....
 [1]

(ii) The target is mounted on wheels. The target has a much larger mass than the mass of the arrow.

Using ideas of momentum, explain the velocity of the target immediately after the arrow sticks into the target.

.....

 [2]

- 19*** A student makes a pendulum using a length of string with a ball of adhesive putty which acts as a bob. The mass of this bob is M .
A similar second pendulum is constructed with the same length of string but with a bob of a smaller mass. The mass of this bob is m .

The arrangement of the pendulums is shown below.

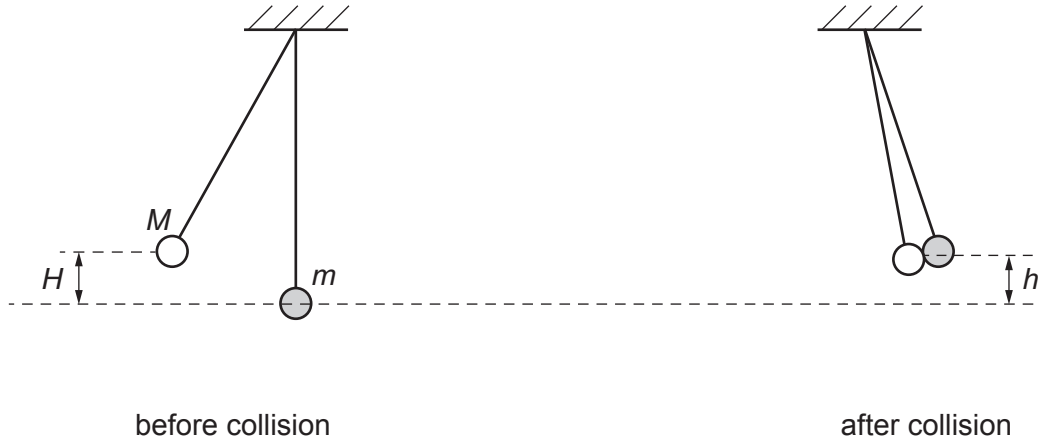

The bob of mass M is pulled back to a vertical height of H from its rest position. It is released and collides with the bob of mass m . The two bobs then stick together and reach a maximum vertical height h from the rest position.

The height h is given by the equation $h = \left(\frac{M}{M+m}\right)^2 H$.

- 20 A small object of mass m is placed on a rotating horizontal metal disc at a distance r from the centre of the disc.

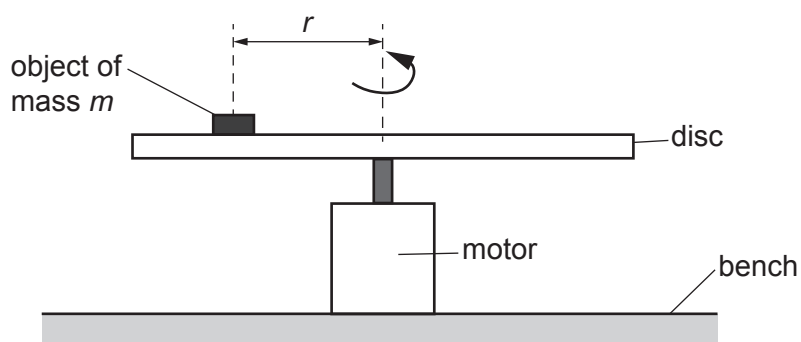

The frequency of rotation is adjusted using a motor attached to the disc.

The frequency of rotation of the disc is slowly increased from zero, until the object slips off. At this point, the friction F acting on the object is equal to the centripetal force.

The friction F is given by the expression $F = kmg$, where k is a constant and g is the acceleration of free fall. The constant k has no units.

- (a) Show that the frequency f at which the object slips off is given by the equation $f^2 = \left(\frac{gk}{4\pi^2}\right) \times \frac{1}{r}$.

[3]

(b) A student plots a graph of $\lg(f/\text{Hz})$ against $\lg(r/\text{m})$.

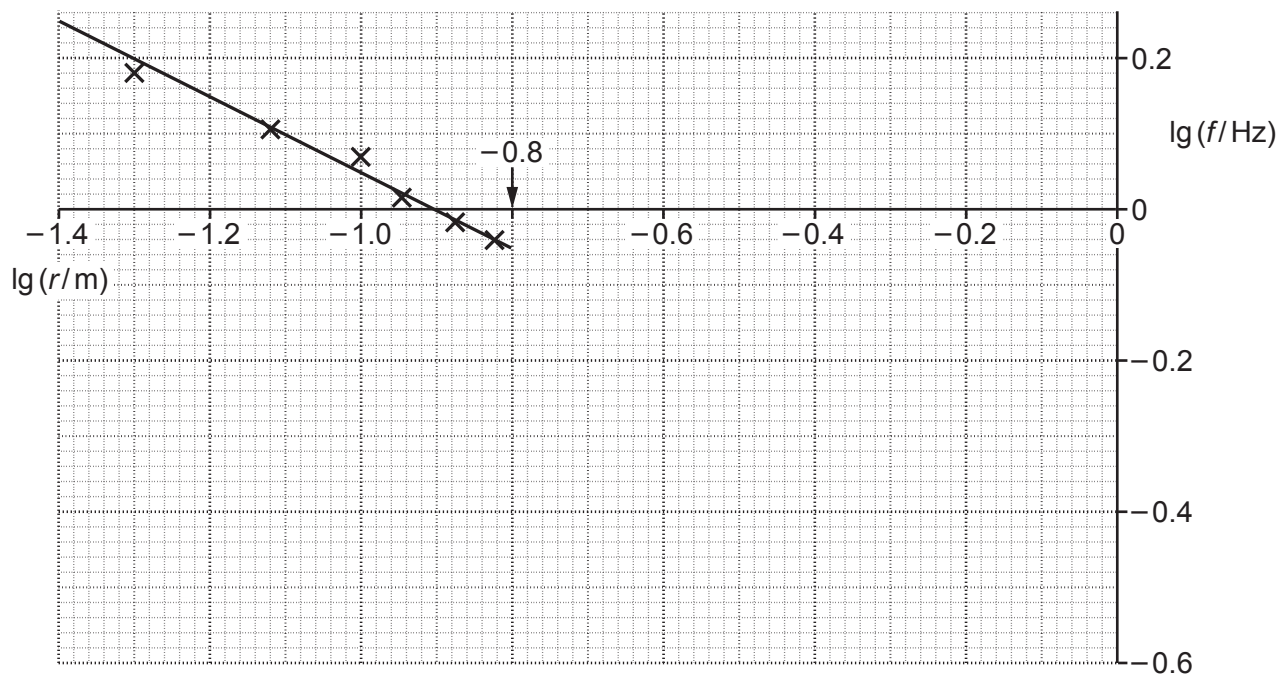

For this graph: $y\text{-intercept} = \frac{1}{2} \times \lg\left(\frac{gk}{4\pi^2}\right)$

Use the graph to determine the constant k . Write your answer to 2 significant figures.

$k = \dots\dots\dots$ [4]

21 A kiln used to harden ceramics is shown below.

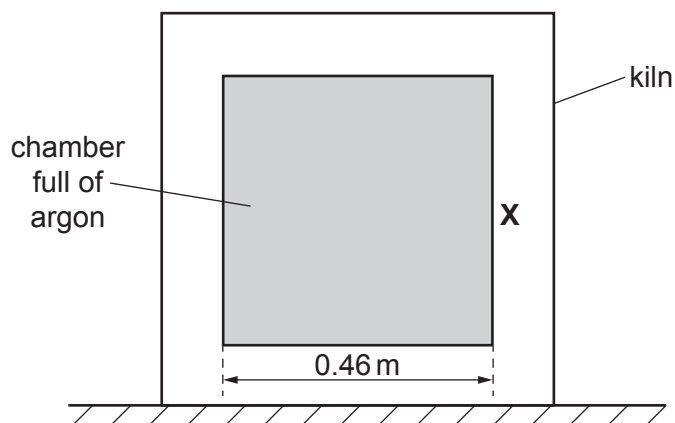

The internal chamber is a cube. Each side of this cube has length 0.46 m. The chamber is sealed and full of argon. Argon behaves as an ideal gas.

- (a) The kiln is initially at 20 °C.
The argon in the kiln has an initial pressure of 100 kPa.
- (i) Calculate the amount of argon n in the chamber in moles.

$$n = \dots\dots\dots \text{ mol [2]}$$

- (ii) The temperature of the kiln is increased from 20 °C to 1300 °C.

Calculate the pressure in kPa at 1300 °C.

$$\text{pressure} = \dots\dots\dots \text{ kPa [2]}$$

(b) The temperature of the kiln is 1300 °C.

A single atom of argon is travelling horizontally towards the vertical side **X** of the chamber. The initial speed of this atom is 990 m s⁻¹. After collision, it rebounds at the same speed.

(i) Calculate the change in momentum Δp of this atom.

- mass of argon atom = 6.6×10^{-26} kg

$\Delta p = \dots\dots\dots$ kg m s⁻¹ [2]

(ii) Assume that this atom does not collide with any other argon atoms inside the chamber. Instead, it travels horizontally, making repeated collisions with the opposite vertical walls of the chamber.

1 Show that the atom makes about 1000 collisions with side **X** in a time interval of 1.0 s.

[1]

2 Calculate the average force F on side **X** made by the atom.

$F = \dots\dots\dots$ N [2]

(iii) Without calculation, explain how your answer to (ii)2 could be used to estimate the total pressure exerted by the atoms of the argon gas in the kiln.

.....

.....

.....

..... [2]

22 A long wooden cylinder is placed into a liquid and it floats as shown.

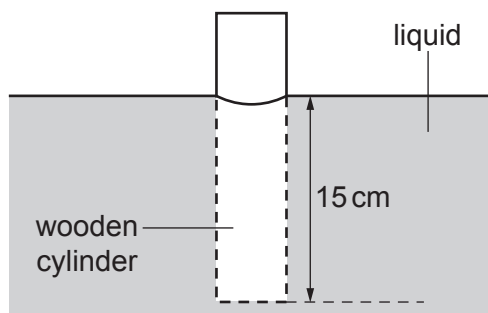

The length of the cylinder below the liquid level is 15 cm.

(a) (i) State **Archimedes' principle**.

.....

 [1]

(ii) The pressure exerted by the liquid alone on the bottom of the cylinder is $1.9 \times 10^3 \text{ Pa}$.
 Calculate the density ρ of the liquid.

$\rho = \dots\dots\dots \text{ kg m}^{-3}$ [2]

(b) The cylinder is pushed down into the liquid and then allowed to oscillate freely.
 The graph of displacement x against time t is shown below.

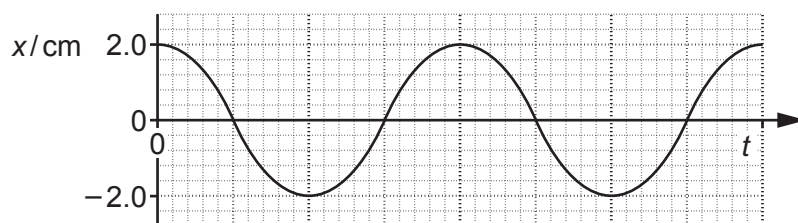

The cylinder oscillates with simple harmonic motion with frequency of 1.4 Hz.

(i) Calculate the displacement, in cm, at time $t = 0.60$ s.

displacement = cm [3]

(ii) Calculate the maximum speed of the oscillating cylinder.

maximum speed = ms^{-1} [2]

(iii) The cylinder is now pushed down further into the liquid before being released. As before, the cylinder oscillates with simple harmonic motion.

State the effect this has on

1 the amplitude

.....

2 the period.

.....

[2]

26
BLANK PAGE

PLEASE DO NOT WRITE ON THIS PAGE

23 In June 2018, the spacecraft Hayabusa2 arrived at an asteroid called Ryugu.

(a) The asteroid orbits the Sun in an elliptical orbit as shown below.

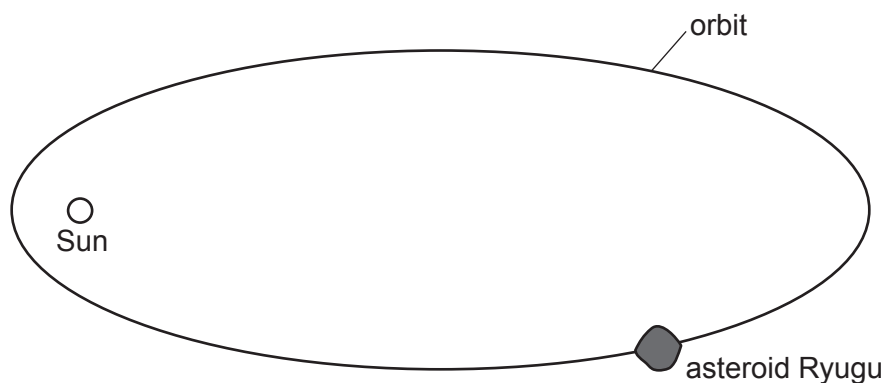

The diagram is **not** drawn to scale.

- (i) Indicate with a letter **X** on the orbit where the asteroid would be moving at maximum speed. [1]
- (ii) Use Kepler's **second law** to explain your answer to (a)(i).

.....

.....

.....

..... [2]

- (b) The gravitational potential at a distance r from the centre of the asteroid Ryugu is V_g . The graph of V_g against $\frac{1}{r}$ for the asteroid is shown below.

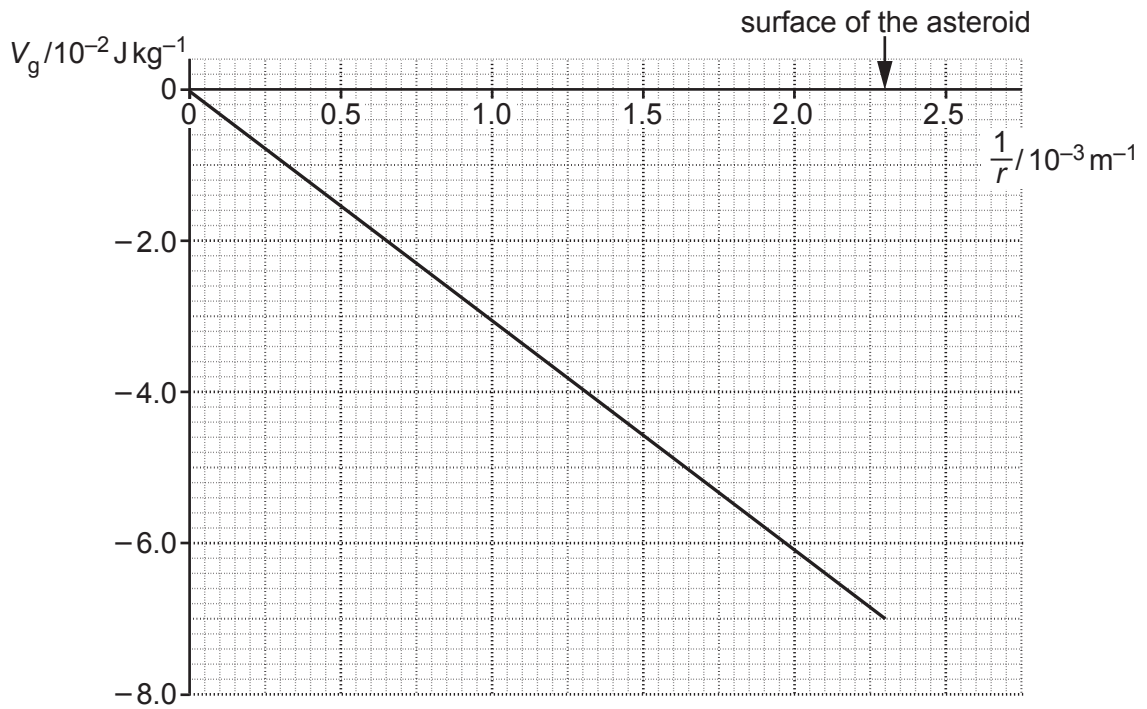

- (i) Define **gravitational potential**.

.....

.....

..... [1]

- (ii) Show that the magnitude of the gradient of the graph is equal to GM , where M is the mass of the asteroid and G is the gravitational constant.

[1]

- (iii) Use the gradient of the graph to show that the mass M of the asteroid is about 4.6×10^{11} kg.

$$M = \dots\dots\dots \text{ kg [2]}$$

- (c) In October 2018, the probe Mobile Asteroid Surface Scout (MASCOT) was released from **rest** from the Hayabusa2 spacecraft from a distance of 600 m from the centre of the asteroid.

Assume that the spacecraft was stationary relative to the asteroid when MASCOT was dropped.

Use information from (b) to calculate the speed of the impact v when MASCOT landed on the surface of the asteroid.

$$v = \dots\dots\dots \text{ m s}^{-1} \text{ [3]}$$

Question 24 is on page 30

(ii) Calculate the radius of Rigel.

radius = m [2]

(c) An astronomer claims to have discovered a white dwarf with a mass twice that of our Sun.

Suggest why this claim must be incorrect.

.....
..... [1]

END OF QUESTION PAPER

ADDITIONAL ANSWER SPACE

If additional space is required, you should use the following lined page(s). The question number(s) must be clearly shown in the margin(s).

A large rectangular area with a solid vertical line on the left side and horizontal dotted lines across the rest of the page, providing space for writing answers.



Copyright Information

OCR is committed to seeking permission to reproduce all third-party content that it uses in its assessment materials. OCR has attempted to identify and contact all copyright holders whose work is used in this paper. To avoid the issue of disclosure of answer-related information to candidates, all copyright acknowledgements are reproduced in the OCR Copyright Acknowledgements Booklet. This is produced for each series of examinations and is freely available to download from our public website (www.ocr.org.uk) after the live examination series. If OCR has unwittingly failed to correctly acknowledge or clear any third-party content in this assessment material, OCR will be happy to correct its mistake at the earliest possible opportunity.

For queries or further information please contact The OCR Copyright Team, The Triangle Building, Shaftesbury Road, Cambridge CB2 8EA.

OCR is part of the Cambridge Assessment Group; Cambridge Assessment is the brand name of University of Cambridge Local Examinations Syndicate (UCLES), which is itself a department of the University of Cambridge.