

# Extraction and uses of metals

## Question paper 2

<b>Level</b>	IGCSE(9-1)
<b>Subject</b>	Chemistry
<b>Exam Board</b>	Edexcel IGCSE
<b>Module</b>	Single Award (Paper 1C)
<b>Topic</b>	Inorganic Chemistry
<b>Sub-Topic</b>	Extraction and uses of metals
<b>Booklet</b>	Question paper 2

**Time Allowed:** 60 minutes

**Score:** /50

**Percentage:** /100

**Grade Boundaries:**

9	8	7	6	5	4	3	2	1
>90%	80%	70%	60%	50%	40%	30%	20%	10%

1 This question is about ways of preventing iron nails from rusting.

(a) This experiment is set up with three iron nails.

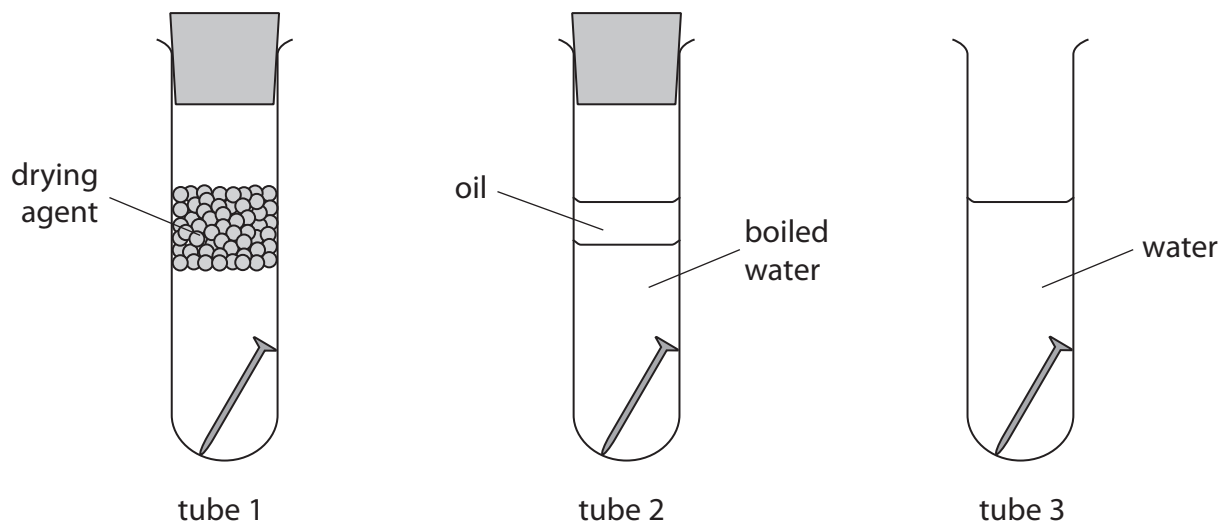

(i) What is the name of the main compound in rust?

(1)

.....

(ii) Why does the nail in tube 1 not rust?

(1)

.....

.....

(iii) What is the purpose of the layer of oil in tube 2?

(1)

.....

.....

(b) Zinc can be used to coat iron nails to prevent them from rusting.

(i) What is the name of this process?

(1)

(ii) If the layer of zinc on the nail is scratched, sacrificial protection prevents the iron from rusting.

Explain, with the help of two ionic half-equations, how this type of sacrificial protection works.

Use symbols from the box in your equations. You may use each symbol once, more than once or not at all.

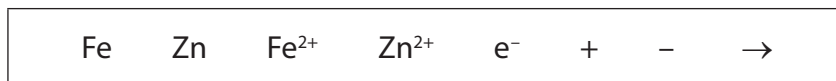

(4)

.....

.....

.....

.....

.....

.....

.....

.....

.....

(c) Electroplating is another method of rust prevention.

This apparatus can be used to electroplate an iron nail.

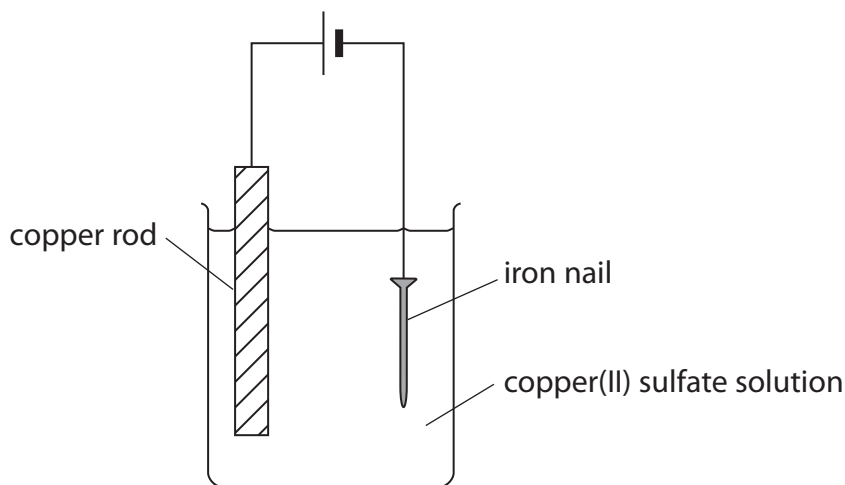

(i) Equation 1 shows the reaction at the copper rod.

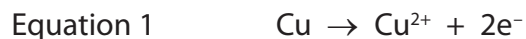

Name this type of reaction, giving a reason for your answer.

(2)

type of reaction .....

reason .....

(ii) Equation 2 shows the reaction at the iron nail.



Use equations 1 and 2 to explain why the colour of the copper(II) sulfate solution does not change during the experiment.

(2)

.....  
 .....  
 .....  
 .....

**(Total for Question 1 = 12 marks)**

2 Molybdenum (Mo) is a metal. It is often used to make an alloy with iron.

Like iron, it is extracted from its oxide. Unlike iron, it occurs mainly as its sulfide.

(a) Molybdenum sulfide is converted into molybdenum oxide by heating in air. The equation for this reaction is

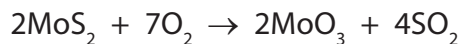

(i) Why is molybdenum said to be oxidised in this reaction?

(1)

(ii) The sulfur dioxide formed in the reaction could form acid rain if it escaped into the atmosphere.

Write a chemical equation for the formation of an acid from sulfur dioxide.

(1)

(b) The table shows the melting points of molybdenum oxide and sulfur dioxide.

	Melting point in °C
molybdenum oxide	800
sulfur dioxide	-75

The melting point indicates the type of bonding and structure in a compound.

(i) What is the type of bonding in a molecule of sulfur dioxide?

(1)

(ii) Explain why the melting point of sulfur dioxide is low.

(2)

- (iii) The melting point of molybdenum oxide suggests that it has ionic bonding. However, it is often represented as a molecular structure.

Deduce the molecular formula of molybdenum oxide as shown in this structure.

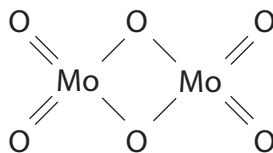

(1)

- (c) The metallic structure of molybdenum gives it some typical properties.

- (i) Describe the metallic structure of molybdenum.

(2)

- (ii) Explain why molybdenum is a good conductor of electricity.

(2)

- (iii) Explain why molybdenum is malleable.

(2)

3 A student was asked to compare the industrial processes used to extract aluminium and iron from their ores.

(a) (i) Name the main ore used as the source of iron.

(1)

.....  
(ii) Aluminium is extracted from purified aluminium oxide.

What is the formula of aluminium oxide?

(1)

.....  
(iii) One solid element is used in the extraction of both metals.

Identify this element and state its purpose in the extraction of aluminium.

(2)

Element .....

Purpose .....

.....  
(iv) One gaseous element takes part in a reaction needed in the extraction of iron.

Identify this element and state its purpose in the extraction of iron.

(2)

Element .....

Purpose .....

.....

(b) The student wrote this statement:

The extractions of aluminium and iron both involve reduction and oxidation reactions.

(i) What name is given to a reaction that involves both reduction and oxidation?

(1)

(ii) Why does this equation represent a reduction reaction?



(1)

(iii) The equation for a reaction that occurs in some extractions of iron is

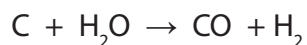

Identify the substance oxidised in this reaction, giving a reason for your choice.

(2)

Substance oxidised .....

Reason .....

.....



(c) Both extractions occur at a high temperature.

Neither extraction uses a catalyst.

(i) What is meant by the term **catalyst**?

(2)

.....

.....

.....

.....

(ii) State one reason why cryolite is used in the extraction of aluminium.

(1)

.....

.....

(d) Several equations can be written for the reactions occurring in the extractions.

(i) Write the chemical equation for the reaction between iron(III) oxide ( $\text{Fe}_2\text{O}_3$ ) and carbon monoxide (CO).

(2)

.....

(ii) This equation represents a reaction used to remove impurities in the extraction of iron.

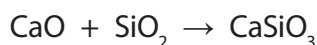

State the type of reaction occurring in this equation.

(1)

.....

(iii) Complete the table by giving the common name for calcium silicate.

(1)

Formula of compound	Chemical name	Common name
CaO	calcium oxide	quicklime
CaSiO <sub>3</sub>	calcium silicate	

**(Total for Question 3 = 17 marks)**

4 The properties of substances can be explained in terms of their bonding and structure.

Electricity can be transmitted by overhead power lines. This method of transmission requires electrical conductors and insulators.

(a) Aluminium is used for the overhead lines because it is a good conductor of electricity and is ductile (can be pulled into a wire).

This diagram can be used to represent the structure of aluminium.

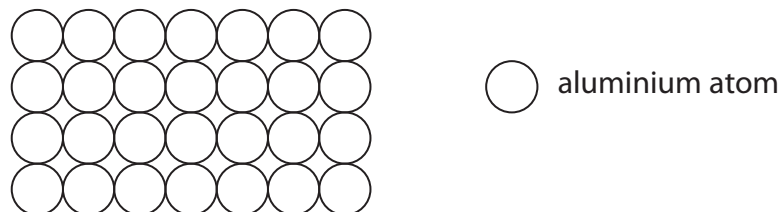

(i) Explain why aluminium is a good conductor of electricity.

(2)

.....

.....

.....

.....

(ii) Suggest why aluminium is ductile.

(2)

.....

.....

.....

.....

(b) The main substance that acts as an insulator in this method of transmission of electricity is air, which is mostly nitrogen.

The power lines are supported by solid insulators. Most solid insulators are manufactured using silica.

The diagram shows the structures of nitrogen and silica.

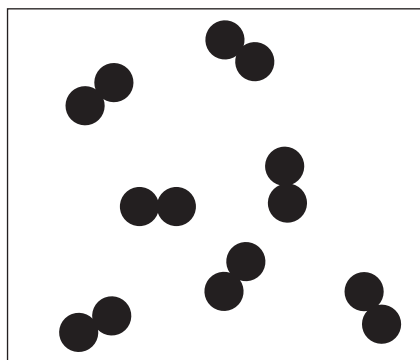

Nitrogen

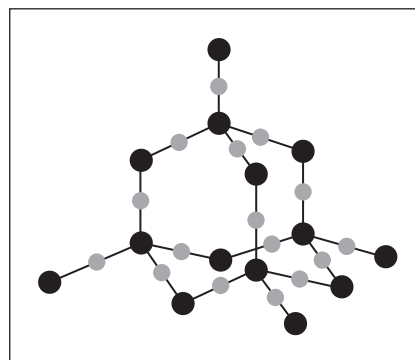

Silica

Explain, in terms of bonding and structure, why nitrogen is a gas at room temperature but silica is a solid with a high melting point.

(5)

Nitrogen .....

.....

.....

.....

.....

.....

Silica .....

.....

.....

.....

.....

.....

**(Total for Question 4 = 9 marks)**