



**Cambridge International Examinations**  
Cambridge International General Certificate of Secondary Education

**PHYSICS**

**0625/13**

Paper 1 Multiple Choice (Core)

**May/June 2017**

**45 minutes**

Additional Materials: Multiple Choice Answer Sheet  
Soft clean eraser  
Soft pencil (type B or HB recommended)



**READ THESE INSTRUCTIONS FIRST**

Write in soft pencil.  
Do not use staples, paper clips, glue or correction fluid.  
Write your name, Centre number and candidate number on the Answer Sheet in the spaces provided unless this has been done for you.  
**DO NOT WRITE IN ANY BARCODES.**

There are **forty** questions on this paper. Answer **all** questions. For each question there are four possible answers **A, B, C** and **D**.  
Choose the **one** you consider correct and record your choice in **soft pencil** on the separate Answer Sheet.

**Read the instructions on the Answer Sheet very carefully.**

Each correct answer will score one mark. A mark will not be deducted for a wrong answer.  
Any rough working should be done in this booklet.  
Electronic calculators may be used.  
Take the weight of 1.0 kg to be 10 N (acceleration of free fall =  $10 \text{ m/s}^2$ ).

The syllabus is approved for use in England, Wales and Northern Ireland as a Cambridge International Level 1/Level 2 Certificate.

This document consists of **17** printed pages and **3** blank pages.

- 1 A candle burns evenly. It is used as a timer.

The candle is lit and burns down to point X in 2 hours.

To which labelled point does the candle burn down after a further 30 minutes?

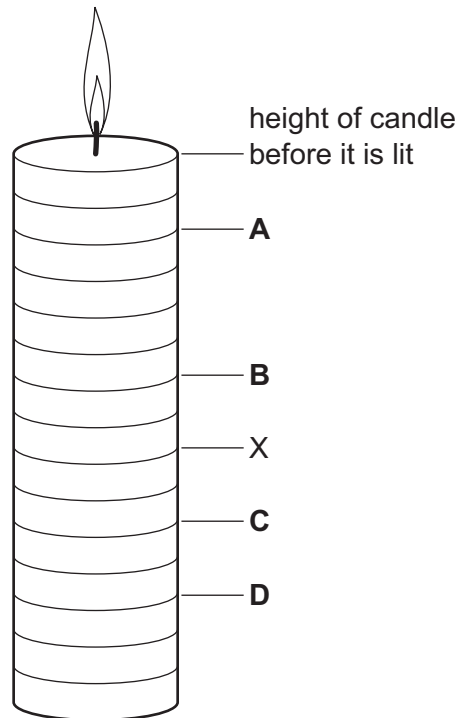

- 2 A pendulum is swinging. Five students each measure the time it takes to swing through ten complete swings.

Three students measure the time as 17.2 s. Another student measures it as 16.9 s, and the fifth student measures it as 17.0 s.

What is the average period of the pendulum?

- A** 1.69 s      **B** 1.70 s      **C** 1.71 s      **D** 1.72 s

- 3 The speed-time graph represents a motorcycle journey.

In which part of the graph is the acceleration equal to zero?

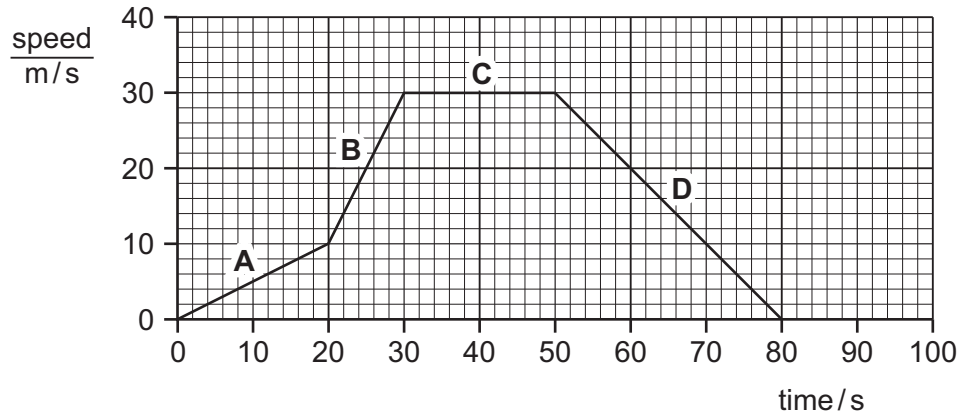

- 4 A shopkeeper pours rice into a dish that hangs from a spring balance. He records the reading.

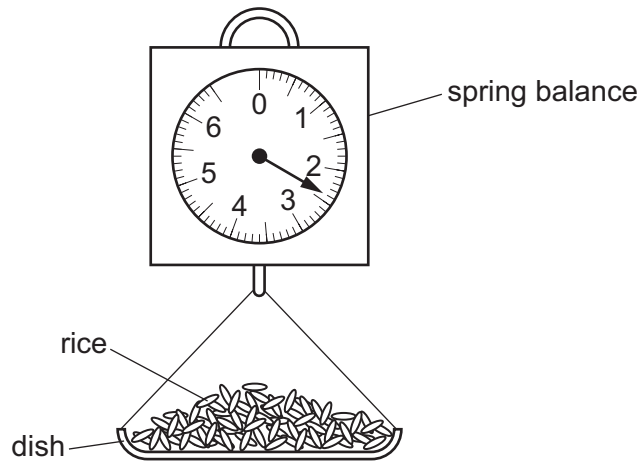

A customer buys some pasta. The shopkeeper notices that the reading on the spring balance, with just pasta in the dish, is the same as it was with just rice in the dish.

Which quantity **must** be the same for the rice and for the pasta?

- A density
- B temperature
- C volume
- D weight

- 5 Four identical steel blocks weigh 120 N in total.

The gravitational field strength  $g$  is 10 N/kg.

What is the mass of one steel block?

- A 3.0 kg      B 12 kg      C 30 kg      D 48 kg

- 6 A steel ball bearing has a mass of 24 g and a density of  $8.0 \text{ g/cm}^3$ . It is lowered into a measuring cylinder containing  $12 \text{ cm}^3$  of water.

What is the new water level in the cylinder?

- A  $3.0 \text{ cm}^3$       B  $4.0 \text{ cm}^3$       C  $15 \text{ cm}^3$       D  $16 \text{ cm}^3$

- 7 The diagram shows an object being acted upon by two forces.



What is the size of the resultant force on the object?

- A 2.0 N      B 3.0 N      C 9.0 N      D 18 N

- 8 A student is asked to investigate the extension of a spring using the apparatus shown in the diagram.

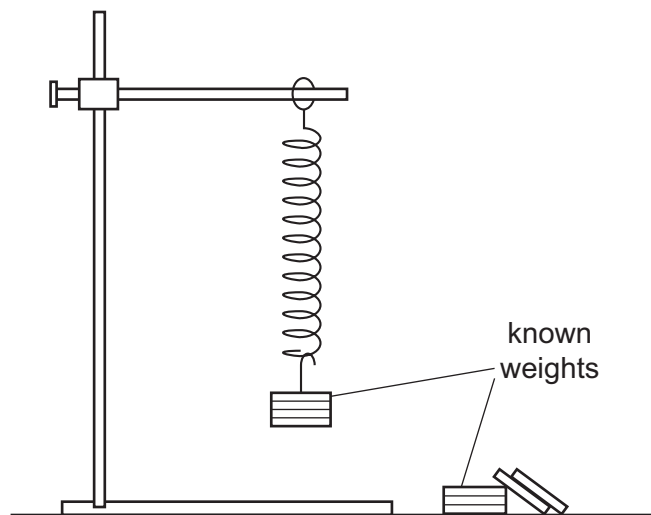

Which other piece of equipment is needed?



- A measuring cylinder  
 B metre rule  
 C stopwatch  
 D protractor

9 In which power station are atoms of one element changed to atoms of other lighter elements?

- A a coal-fired power station
- B a hydroelectric power station
- C a nuclear power station
- D a solar power station

10 The diagrams show four different athletes training by doing pull-ups.

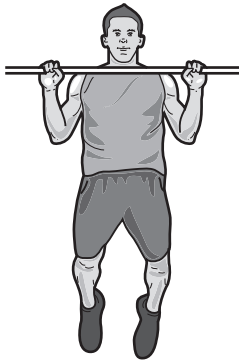
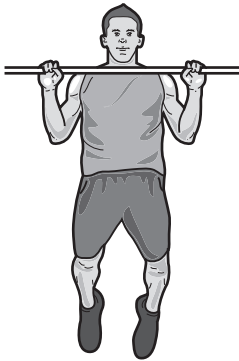
Which athlete does the most work?

|                                                                                    |                                                                                    |                                                                                     |                                                                                      |
|------------------------------------------------------------------------------------|------------------------------------------------------------------------------------|-------------------------------------------------------------------------------------|--------------------------------------------------------------------------------------|
| <b>A</b>                                                                           | <b>B</b>                                                                           | <b>C</b>                                                                            | <b>D</b>                                                                             |
|  |  |  |  |
| weight of athlete = 700 N                                                          | weight of athlete = 700 N                                                          | weight of athlete = 800 N                                                           | weight of athlete = 800 N                                                            |
| distance lifted = 0.50 m                                                           | distance lifted = 0.55 m                                                           | distance lifted = 0.50 m                                                            | distance lifted = 0.55 m                                                             |

11 A student uses her thumb to push in a drawing pin (thumb tack) into a notice board.

The pin goes into the board but does not penetrate her thumb.

Which statement explains this?

- A The force exerted by the pin on her thumb is greater than the force exerted on the notice board.
- B The force exerted by the pin on the notice board is greater than the force exerted on her thumb.
- C The pressure of the pin on her thumb is greater than the pressure on the notice board.
- D The pressure of the pin on the notice board is greater than the pressure on her thumb.

- 12 A solid cube has sides 0.50 m long and a mass of 120 kg. It stands on the ground on one face.

What pressure does the cube exert on the ground?

- A  $480 \text{ kg/m}^3$     B  $960 \text{ kg/m}^3$     C  $4800 \text{ N/m}^2$     D  $9600 \text{ N/m}^2$

- 13 The diagram represents molecules of a gas inside a closed container of constant volume.

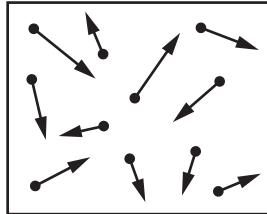

What happens to the molecules of the gas when the container is heated?

- A They expand.  
B They get closer together.  
C They hit the container walls with less force.  
D They move faster.
- 14 Brownian motion is observed when using a microscope to look at smoke particles in air.

What causes the smoke particles to move at random?

- A Smoke particles are hit by air molecules.  
B Smoke particles are moved by convection currents in the air.  
C Smoke particles have different weights and fall at different speeds.  
D Smoke particles hit the walls of the container.
- 15 The temperature of a bridge rises from  $5^\circ\text{C}$  on a cold night to  $25^\circ\text{C}$  at midday.

What happens to the bridge?

- A It becomes heavier.  
B It becomes more dense.  
C Its length increases.  
D Its mass increases.

16 Equal masses of two different liquids are put into identical beakers.

Liquid 1 is heated for 100 s and liquid 2 is heated for 200 s by heaters of the **same power**.

Each liquid has the same rise in temperature.

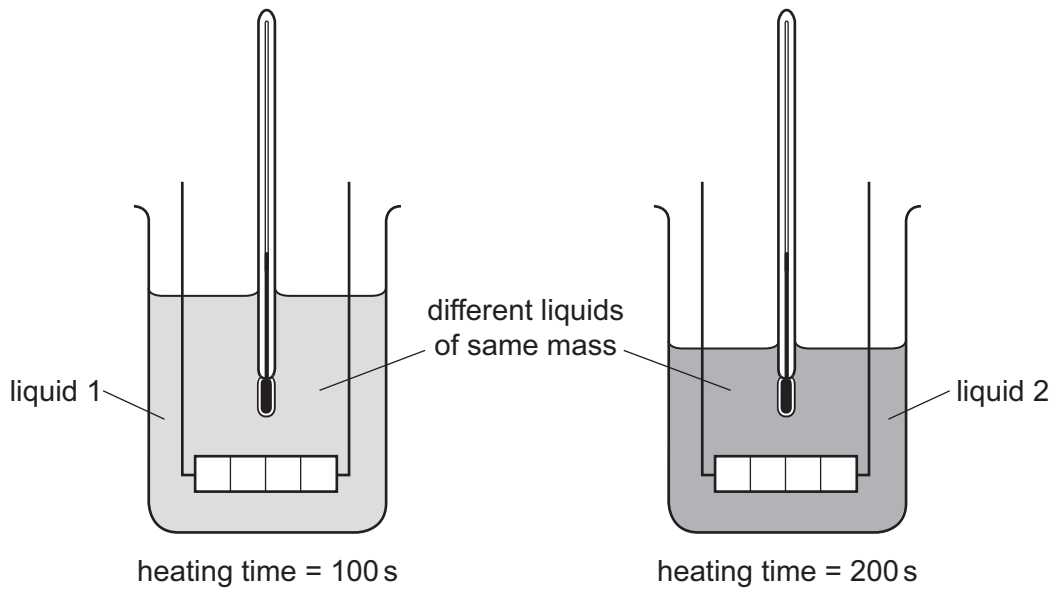

Which statement is correct?

- A Each beaker of liquid has the same thermal capacity.
- B Each beaker of liquid receives the same energy.
- C Liquid 1 receives more energy than liquid 2.
- D The thermal capacity of liquid 1 is less than the thermal capacity of liquid 2.

- 17 A solid substance is heated at a constant rate. The solid changes into a liquid and then into a gas.

The graph shows how the temperature of the substance changes.

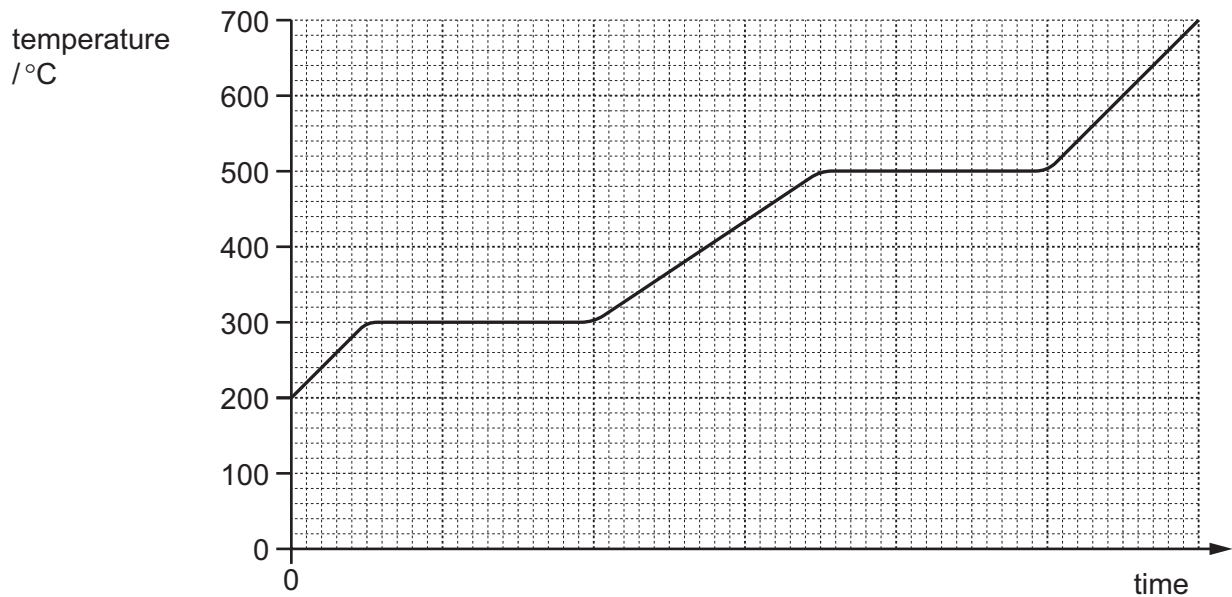

What is the melting point and what is the boiling point of the substance?

|          | melting point/°C | boiling point/°C |
|----------|------------------|------------------|
| <b>A</b> | 200              | 300              |
| <b>B</b> | 200              | 500              |
| <b>C</b> | 300              | 500              |
| <b>D</b> | 300              | 700              |



18 A copper bar and a wooden bar are joined. A piece of paper is wrapped tightly around the join.

The bar is heated strongly at the centre for a short time, and the paper goes brown on one side only.

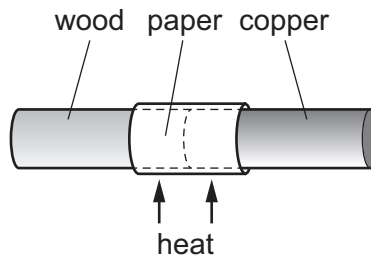

Which side goes brown, and what does this show about wood and copper?

|          | brown side | wood      | copper    |
|----------|------------|-----------|-----------|
| <b>A</b> | copper     | conductor | insulator |
| <b>B</b> | copper     | insulator | conductor |
| <b>C</b> | wood       | conductor | insulator |
| <b>D</b> | wood       | insulator | conductor |

19 Which types of thermal energy transfer require a medium?

- A** conduction and convection
- B** conduction only
- C** convection and radiation
- D** radiation only

20 What causes the change in direction when light travels from air into glass?

- A** The amplitude of the light changes.
- B** The colour of the light changes.
- C** The frequency of the light changes.
- D** The speed of the light changes.

21 Which diagram shows how a converging lens forms a real image of an object O?

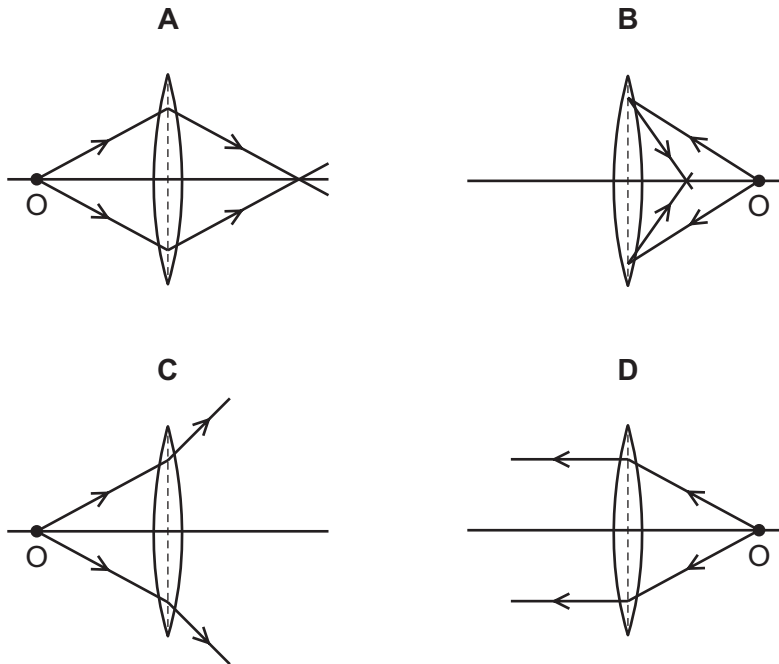

22 Which diagram shows what happens when a ray of white light passes through a prism?

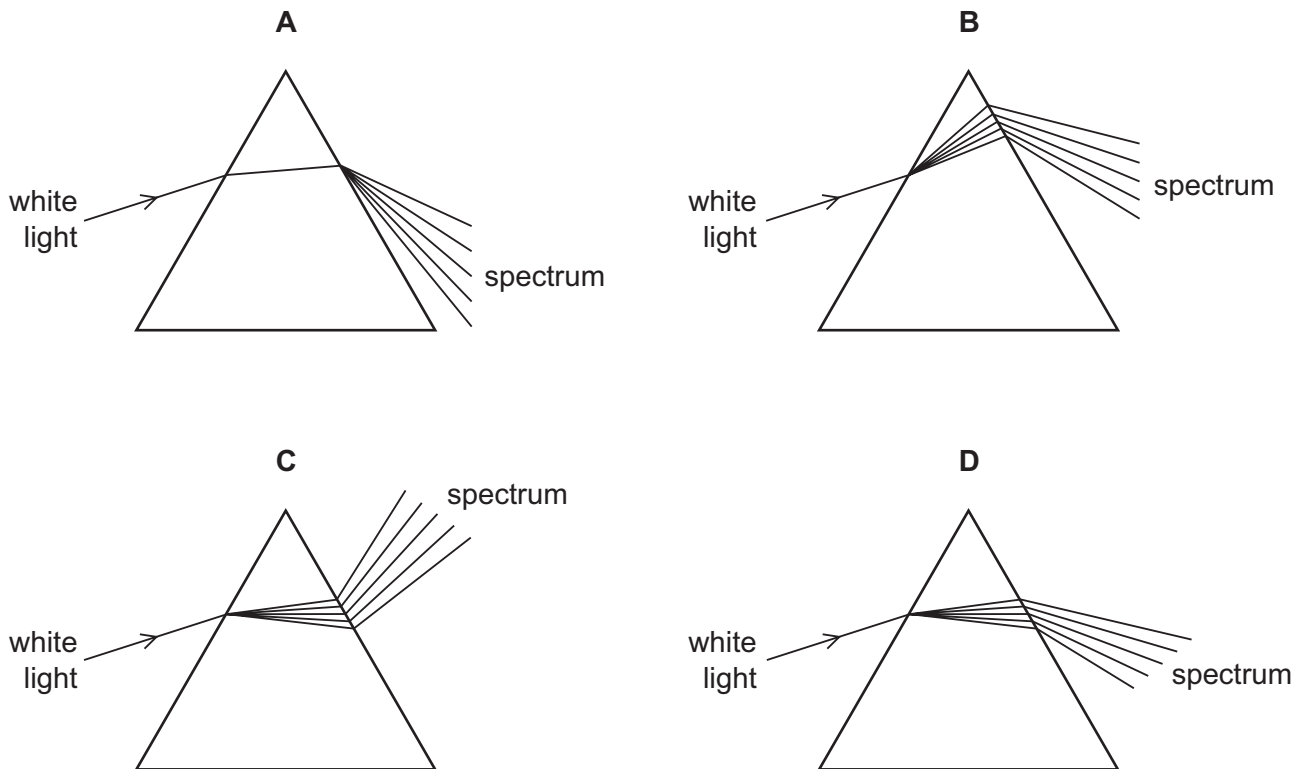

23 The table shows different types of wave in the electromagnetic spectrum.

|             |             |                 |               |                   |        |            |
|-------------|-------------|-----------------|---------------|-------------------|--------|------------|
| radio waves | micro-waves | infra-red waves | visible light | ultraviolet waves | X-rays | gamma rays |
|-------------|-------------|-----------------|---------------|-------------------|--------|------------|

Where do all the waves travel at the same speed?

- A in a vacuum
- B in diamond
- C in glass
- D in water

24 The diagrams show four sources of waves.

Which source produces longitudinal waves?

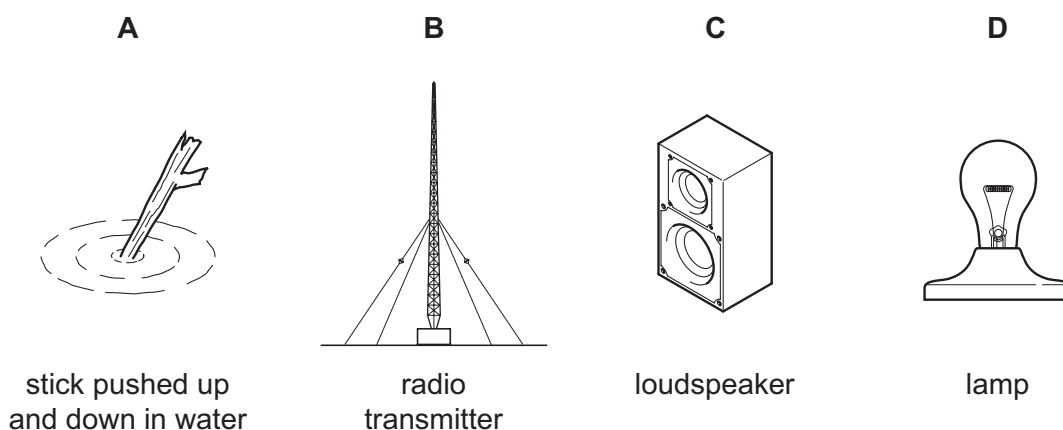

25 A fire alarm is not loud enough and the pitch is too low. An engineer adjusts the alarm so that it produces a louder note of a higher pitch.

What effect does this have on the amplitude and on the frequency of the sound?

|   | amplitude | frequency |
|---|-----------|-----------|
| A | larger    | greater   |
| B | larger    | smaller   |
| C | smaller   | greater   |
| D | smaller   | smaller   |

26 From which materials are the coil and the core of an electromagnet made?

|          | coil      | core      |
|----------|-----------|-----------|
| <b>A</b> | copper    | soft iron |
| <b>B</b> | copper    | steel     |
| <b>C</b> | soft iron | copper    |
| <b>D</b> | steel     | soft iron |

27 In which way are a bar magnet and an electromagnet similar?

- A** A bar magnet and an electromagnet are always magnetised when stored.
- B** A bar magnet and an electromagnet can both be used to separate magnetic and non-magnetic materials.
- C** A bar magnet can be made of steel and an electromagnet uses a steel core.
- D** The magnetic field strength of a bar magnet and of an electromagnet can both be varied.

28 Which material is a conductor of electricity?

- A** brass
- B** glass
- C** plastic
- D** wood

- 29 The diagram shows a circuit containing two resistors of resistance  $1.0\ \Omega$  and  $2.0\ \Omega$ .

A voltmeter is connected across the  $1.0\ \Omega$  resistor by connecting P to X.

The reading on the voltmeter is  $6.0\ \text{V}$ .

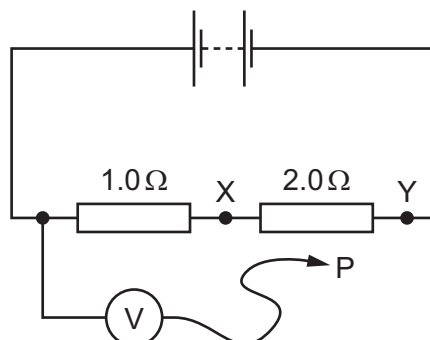

P is moved to point Y in the circuit.

What is the new reading on the voltmeter?

- A**  $3.0\ \text{V}$       **B**  $6.0\ \text{V}$       **C**  $12\ \text{V}$       **D**  $18\ \text{V}$
- 30 The circuit diagram shows a simple circuit with a battery of electromotive force (e.m.f.)  $6.0\ \text{V}$  and two bulbs each of resistance  $2.0\ \Omega$ .

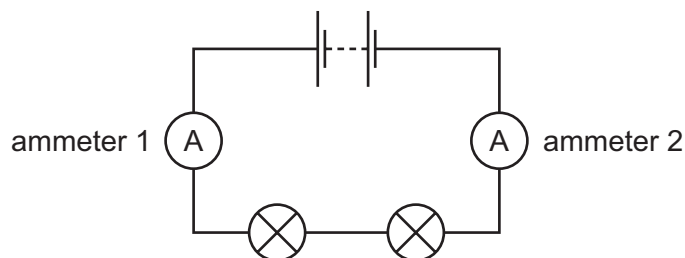

Which row gives the readings on the ammeters?

|          | reading on<br>ammeter 1 / A | reading on<br>ammeter 2 / A |
|----------|-----------------------------|-----------------------------|
| <b>A</b> | 1.5                         | 0                           |
| <b>B</b> | 1.5                         | 1.5                         |
| <b>C</b> | 3.0                         | 0                           |
| <b>D</b> | 3.0                         | 1.5                         |

31 The diagram shows three identical heating elements connected to a power supply.

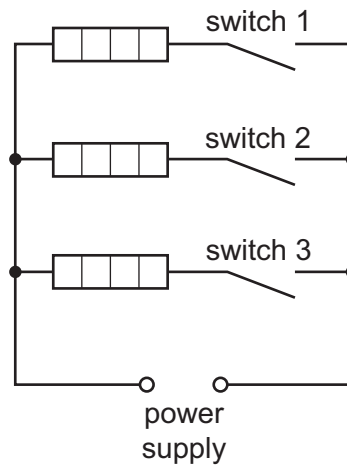

Which arrangement of switches causes **most** power to be used?

|          | switch 1 | switch 2 | switch 3 |
|----------|----------|----------|----------|
| <b>A</b> | closed   | closed   | closed   |
| <b>B</b> | closed   | open     | closed   |
| <b>C</b> | closed   | open     | open     |
| <b>D</b> | open     | closed   | closed   |

32 A student connects a variable potential divider (potentiometer) circuit.

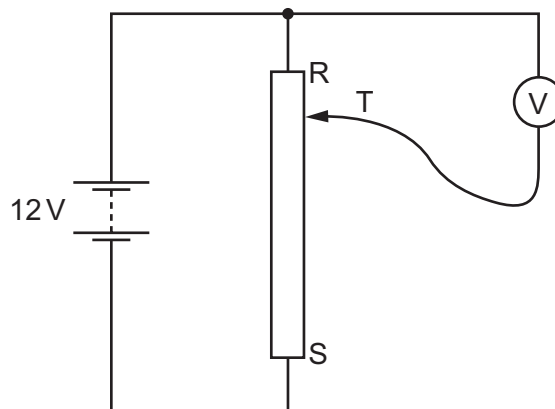

What happens to the reading on the voltmeter as the sliding terminal T is moved from R to S?

- A** It decreases from 12V to 0V.
- B** It increases from 0V to 12V.
- C** It remains at 0V.
- D** It remains at 12V.

- 33 The diagram shows a circuit used to make a light detector.

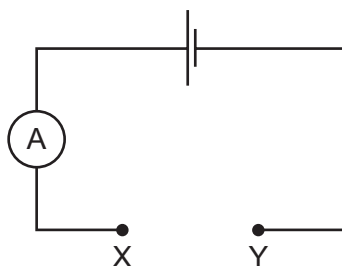

One component is connected between X and Y.

Which component causes the ammeter reading to increase when the light gets brighter?

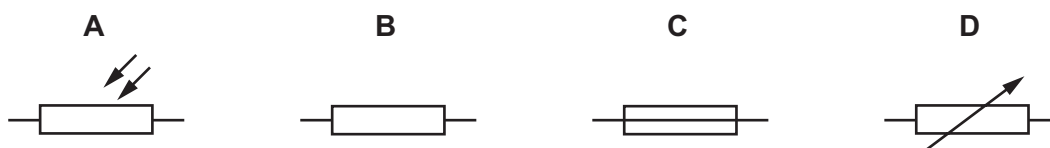

- 34 A circuit-breaker is designed to protect a circuit which usually carries a current of 2 A.

The time taken to break the circuit depends on the current, as shown in the graph.

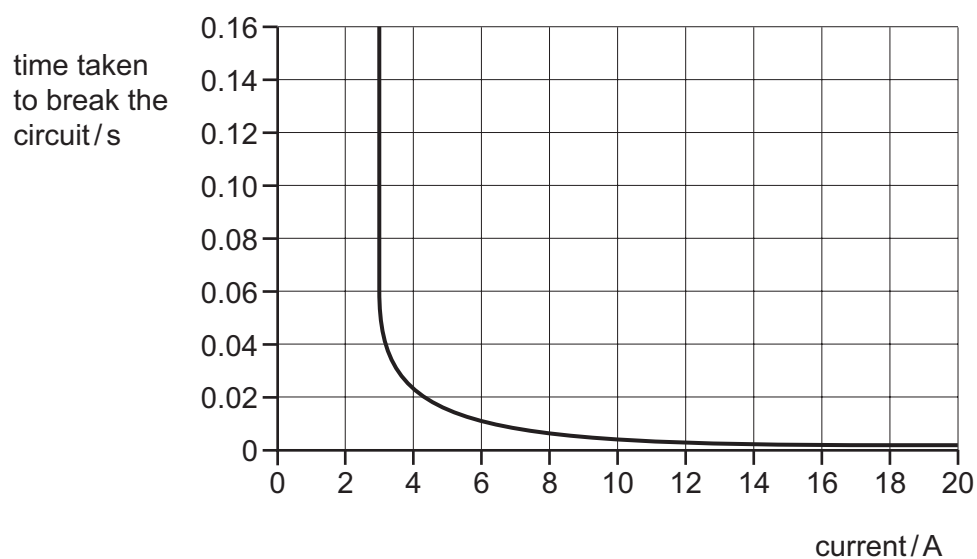

What happens when the current in the circuit is 2 A and what happens when the current is 18 A?

|          | when the current is 2 A                | when the current is 18 A               |
|----------|----------------------------------------|----------------------------------------|
| <b>A</b> | the circuit breaks in less than 0.01 s | the circuit breaks in less than 0.01 s |
| <b>B</b> | the circuit breaks in less than 0.01 s | the circuit does not break             |
| <b>C</b> | the circuit does not break             | the circuit breaks in less than 0.01 s |
| <b>D</b> | the circuit does not break             | the circuit does not break             |

- 35 A wire moves in the direction shown between the poles of a magnet.

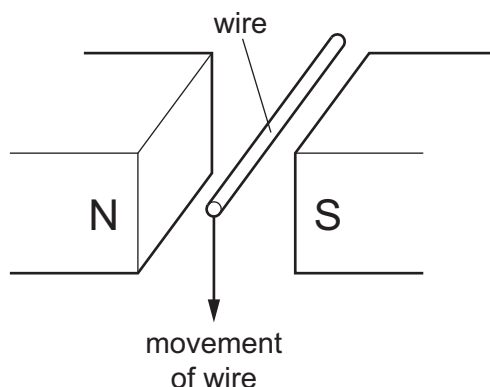

Which change increases the magnitude of the induced electromotive force (e.m.f.) across the ends of the wire?

- A increasing the gap between the poles of the magnet
- B moving the wire faster
- C using a shorter wire
- D using a thinner wire

- 36 What is the purpose of a relay?

- A to change a large voltage into a small voltage
- B to change a small voltage into a large voltage
- C to use a large current to switch on a small current
- D to use a small current to switch on a large current

- 37 Which description of a neutral atom of copper is correct?

- A a nucleus surrounded by electrons
- B a nucleus surrounded by molecules
- C electrons surrounded by a nucleus
- D electrons surrounded by molecules

- 38 A nuclide of iodine is represented by  ${}_{53}^{131}\text{I}$ .

How many neutrons are in a nucleus of this nuclide?

- A 53
- B 78
- C 131
- D 184



39 A sample of radioactive isotope is decaying.

The nuclei of which atoms will decay first?

- A It is impossible to know because radioactive decay is random.
- B It is impossible to know unless the age of the material is known.
- C The atoms near the centre will decay first because they are surrounded by more atoms.
- D The atoms near the surface will decay first because the radiation can escape more easily.

40 The diagram shows a decay curve for a radioactive substance.

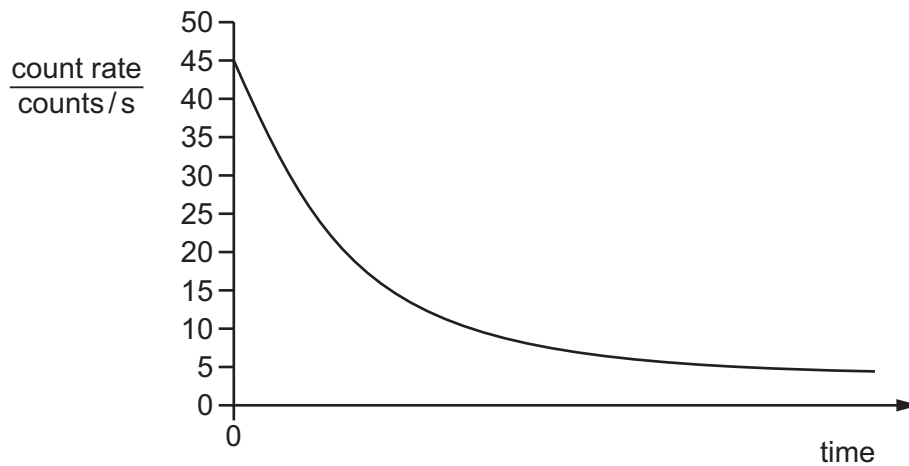

According to the curve shown, what is the background radiation count?

- A 40 counts/s
- B 20 counts/s
- C 5 counts/s
- D 0 counts/s



**BLANK PAGE**

**BLANK PAGE**

---

Permission to reproduce items where third-party owned material protected by copyright is included has been sought and cleared where possible. Every reasonable effort has been made by the publisher (UCLES) to trace copyright holders, but if any items requiring clearance have unwittingly been included, the publisher will be pleased to make amends at the earliest possible opportunity.

To avoid the issue of disclosure of answer-related information to candidates, all copyright acknowledgements are reproduced online in the Cambridge International Examinations Copyright Acknowledgements Booklet. This is produced for each series of examinations and is freely available to download at [www.cie.org.uk](http://www.cie.org.uk) after the live examination series.

Cambridge International Examinations is part of the Cambridge Assessment Group. Cambridge Assessment is the brand name of University of Cambridge Local Examinations Syndicate (UCLES), which is itself a department of the University of Cambridge.