

Write your name here

Surname

Other names

**Pearson**  
**Edexcel GCE**

Centre Number

--	--	--	--	--	--

Candidate Number

--	--	--	--	--	--

# Chemistry

**Advanced**

**Unit 5: General Principles of Chemistry II – Transition  
Metals and Organic Nitrogen Chemistry  
(including synoptic assessment)**

Wednesday 22 June 2016 – Morning

**Time: 1 hour 40 minutes**

Paper Reference

**6CH05/01**

**You must have: Data Booklet**

**Candidates may use a calculator.**

Total Marks

## Instructions

- Use **black** ink or ball-point pen.
- **Fill in the boxes** at the top of this page with your name, centre number and candidate number.
- Answer **all** questions.
- Answer the questions in the spaces provided  
– *there may be more space than you need.*

## Information

- The total mark for this paper is 90.
- The marks for **each** question are shown in brackets  
– *use this as a guide as to how much time to spend on each question.*
- Questions labelled with an **asterisk** (\*) are ones where the quality of your written communication will be assessed  
– *you should take particular care with your spelling, punctuation and grammar, as well as the clarity of expression, on these questions.*
- A Periodic Table is printed on the back cover of this paper.

## Advice

- Read each question carefully before you start to answer it.
- Keep an eye on the time.
- Try to answer every question.
- Check your answers if you have time at the end.

Turn over ►

P46661A

©2016 Pearson Education Ltd.

3/6/6/3/5/5/e2



**PEARSON**

## SECTION A

Answer ALL the questions in this section. You should aim to spend no more than 20 minutes on this section. For each question, select one answer from A to D and put a cross in the box . If you change your mind, put a line through the box  and then mark your new answer with a cross .

1 Which of the following gives the oxidation states of manganese in the ions shown?

	$\text{MnO}_4^{2-}$	$\text{MnO}_3^-$
<input type="checkbox"/> A	+7	+6
<input type="checkbox"/> B	+6	+5
<input type="checkbox"/> C	+7	+5
<input type="checkbox"/> D	+6	+6

(Total for Question 1 = 1 mark)

2 Which of the following gives the electrodes and electrolyte that are used in an alkaline hydrogen fuel cell?

	Electrodes	Electrolyte
<input type="checkbox"/> A	graphite	potassium hydroxide solution
<input type="checkbox"/> B	graphite	water with a little salt
<input type="checkbox"/> C	platinum	potassium hydroxide solution
<input type="checkbox"/> D	platinum	water with a little salt

(Total for Question 2 = 1 mark)

DO NOT WRITE IN THIS AREA

DO NOT WRITE IN THIS AREA

DO NOT WRITE IN THIS AREA



3 Which of the following **cannot** be used to detect alcohol in a breathalyser test?

- A Fractional distillation
- B Fuel cell
- C Infrared spectroscopy
- D Reduction of dichromate(VI) ions

(Total for Question 3 = 1 mark)

4 A titration using potassium manganate(VII) in dilute sulfuric acid can be used to determine the percentage of

- A aspirin in aspirin tablets.
- B chlorine in bleach.
- C copper in an alloy.
- D iron(II) sulfate in iron tablets.

(Total for Question 4 = 1 mark)

5 Which of the following gives the electronic configurations for a chromium atom and a chromium(II) ion?

	Cr	Cr <sup>2+</sup>
<input type="checkbox"/> A	[Ar]3d <sup>4</sup> 4s <sup>2</sup>	[Ar]3d <sup>4</sup>
<input type="checkbox"/> B	[Ar]3d <sup>5</sup> 4s <sup>1</sup>	[Ar]3d <sup>4</sup>
<input type="checkbox"/> C	[Ar]3d <sup>4</sup> 4s <sup>2</sup>	[Ar]3d <sup>2</sup> 4s <sup>2</sup>
<input type="checkbox"/> D	[Ar]3d <sup>5</sup> 4s <sup>1</sup>	[Ar]3d <sup>3</sup> 4s <sup>1</sup>

(Total for Question 5 = 1 mark)



- 6 Aqueous sodium hydroxide and aqueous ammonia are added to separate solutions of the same metal ion. The observations are shown in the table below.

Reagent added	A few drops	Excess
NaOH(aq)	green precipitate	green precipitate remains
NH <sub>3</sub> (aq)	green precipitate	green precipitate dissolves to form a blue solution

The metal ion is

- A Cr<sup>3+</sup>(aq).  
 B Fe<sup>2+</sup>(aq).  
 C Fe<sup>3+</sup>(aq).  
 D Ni<sup>2+</sup>(aq).

(Total for Question 6 = 1 mark)

- 7 The reaction between cerium(IV) ions and thallium(I) ions is very slow.



Which of these ions could catalyse this reaction?

- A Al<sup>3+</sup>  
 B Fe<sup>3+</sup>  
 C Na<sup>+</sup>  
 D Zn<sup>2+</sup>

(Total for Question 7 = 1 mark)

- 8 Which of these hydroxides is amphoteric?

- A Cu(OH)<sub>2</sub>  
 B Mg(OH)<sub>2</sub>  
 C Ni(OH)<sub>2</sub>  
 D Zn(OH)<sub>2</sub>

(Total for Question 8 = 1 mark)



- 9 During a titration between acidified manganate(VII) ions and sulfate(IV) ions, the manganate(VII) ions are reduced to manganese(II) ions and the sulfate(IV) ions are oxidized to sulfate(VI) ions.

The mole ratio of manganate(VII) ions to sulfate(IV) ions in this reaction is

- A 5:2  
 B 7:4  
 C 2:5  
 D 4:7

(Total for Question 9 = 1 mark)

- 10 The total number of compounds with the structural formula  $C_6H_3CH_3(NO_2)_2$ , which contain a benzene ring, is

- A four.  
 B five.  
 C six.  
 D seven.

(Total for Question 10 = 1 mark)

Use this space for any rough working. Anything you write in this space will gain no credit.



11 This question is about the ester shown below.

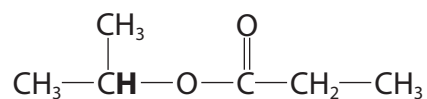

(a) The number of peaks seen in the **low** resolution proton nmr spectrum of this ester is (1)

- A two.
- B three.
- C four.
- D five.

(b) The peak in the **high** resolution proton nmr spectrum corresponding to the proton in **bold** on the structure above will (1)

- A not be split.
- B be split into three peaks.
- C be split into four peaks.
- D be split into seven peaks.

(Total for Question 11 = 2 marks)

Use this space for any rough working. Anything you write in this space will gain no credit.

DO NOT WRITE IN THIS AREA

DO NOT WRITE IN THIS AREA

DO NOT WRITE IN THIS AREA



DO NOT WRITE IN THIS AREA

DO NOT WRITE IN THIS AREA

DO NOT WRITE IN THIS AREA

12 Safranal is one of the substances that contributes to the aroma of saffron.

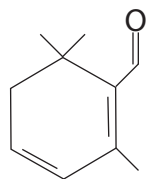

Separate samples of safranal were tested with bromine water, 2,4-dinitrophenylhydrazine and Fehling's solution.

What are the final observations when safranal is tested with each of those reagents?

	Bromine water	2,4-dinitrophenylhydrazine	Fehling's solution
<input type="checkbox"/> <b>A</b>	orange solution	orange solution	red precipitate
<input type="checkbox"/> <b>B</b>	colourless solution	orange precipitate	red precipitate
<input type="checkbox"/> <b>C</b>	orange solution	orange solution	blue solution
<input type="checkbox"/> <b>D</b>	colourless solution	orange precipitate	blue solution

(Total for Question 12 = 1 mark)

Use this space for any rough working. Anything you write in this space will gain no credit.



13 The structure of the organic product of the reaction between phenol and excess bromine water is

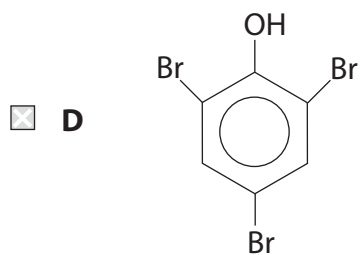
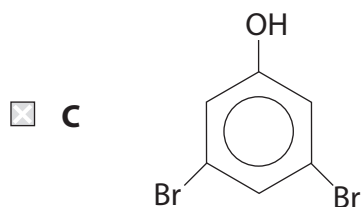
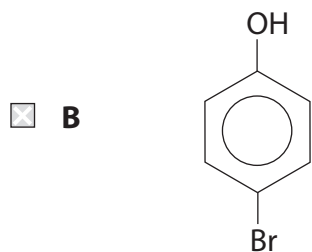
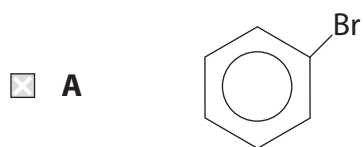

(Total for Question 13 = 1 mark)

Use this space for any rough working. Anything you write in this space will gain no credit.

DO NOT WRITE IN THIS AREA

DO NOT WRITE IN THIS AREA

DO NOT WRITE IN THIS AREA





- 14 If it is assumed that the structure of benzene has three localised double bonds (structure **X**), the calculated standard enthalpy change of hydrogenation is  $-360 \text{ kJ mol}^{-1}$ .

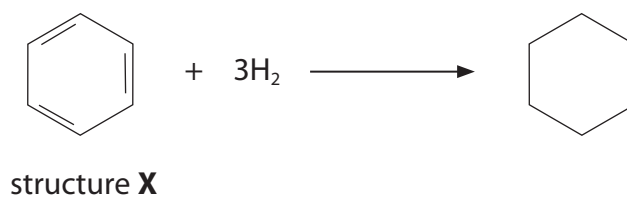

The actual standard enthalpy change of hydrogenation of benzene is  $-208 \text{ kJ mol}^{-1}$ .

From these data, it can be deduced that the

- A** actual benzene structure is kinetically more stable than structure **X** as it requires a high activation energy to react.
- B** actual benzene structure is thermodynamically more stable than structure **X** as it has a lower enthalpy content.
- C** structure **X** is kinetically unstable as it undergoes addition reactions at room temperature.
- D** structure **X** is thermodynamically more stable than the actual benzene structure as the standard enthalpy change of hydrogenation is more exothermic.

**(Total for Question 14 = 1 mark)**

**Use this space for any rough working. Anything you write in this space will gain no credit.**



15 The repeat unit for poly(propenamide) is

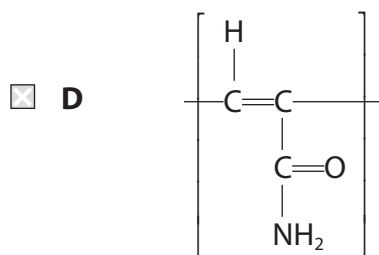
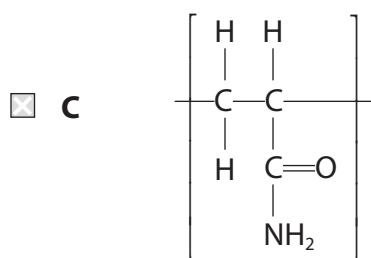
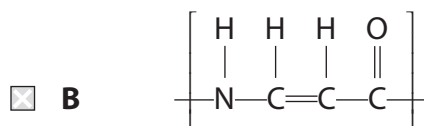
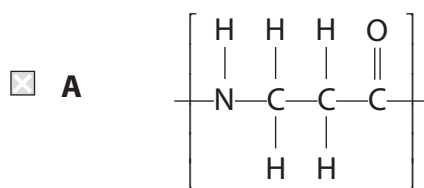

(Total for Question 15 = 1 mark)

Use this space for any rough working. Anything you write in this space will gain no credit.



16 The structures of three amino acids are shown in the table.

Amino acid	Structure
cysteine	$\text{HSCH}_2\text{CH}(\text{NH}_2)\text{COOH}$
glycine	$\text{H}_2\text{NCH}_2\text{COOH}$
threonine	$\text{CH}_3\text{CH}(\text{OH})\text{CH}(\text{NH}_2)\text{COOH}$

The tripeptide glycine-cysteine-threonine is

- A  $\text{H}_2\text{NCH}_2\text{CONHCH}(\text{CH}(\text{OH})\text{CH}_3)\text{CONHCH}(\text{CH}_2\text{SH})\text{COOH}$
- B  $\text{H}_2\text{NCH}_2\text{CONHCH}(\text{CH}_2\text{SH})\text{CONHCH}(\text{CH}(\text{OH})\text{CH}_3)\text{COOH}$
- C  $\text{H}_2\text{NCH}(\text{CH}(\text{OH})\text{CH}_3)\text{CONHCH}(\text{CH}_3\text{SH})\text{CONHCH}_2\text{COOH}$
- D  $\text{H}_2\text{NCH}(\text{CH}_2\text{SH})\text{CONHCH}_2\text{CONHCH}(\text{CH}(\text{OH})\text{CH}_3)\text{COOH}$

(Total for Question 16 = 1 mark)

17 The amino acid alanine,  $\text{H}_2\text{NCH}(\text{CH}_3)\text{COOH}$ , exists as a solid at room temperature.

The most important reason for this is that it

- A exists as a zwitterion.
- B forms hydrogen bonds.
- C is amphoteric.
- D has strong London forces.

(Total for Question 17 = 1 mark)

18 Complete combustion of a hydrocarbon produced 0.66 g of carbon dioxide and 0.225 g of water.

Which of the following molecular formulae is consistent with these data?

- A  $\text{C}_3\text{H}_6$ .
- B  $\text{C}_3\text{H}_8$ .
- C  $\text{C}_6\text{H}_6$ .
- D  $\text{C}_6\text{H}_{10}$ .

(Total for Question 18 = 1 mark)



19 Phenol can be produced from benzene as shown in the reaction sequence below.

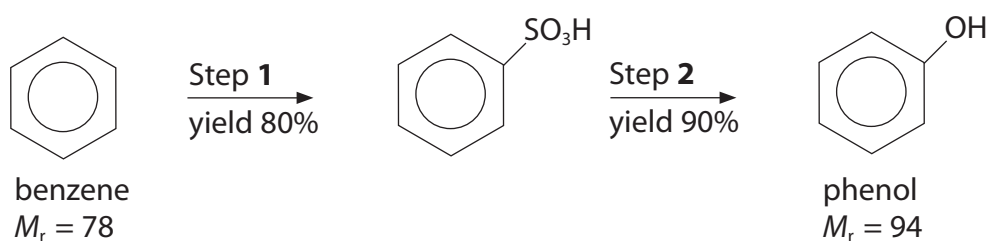

The mass of phenol, to 2 decimal places, produced from 3.90 g of benzene is

- A 3.38 g.
- B 3.76 g.
- C 4.23 g.
- D 4.70 g.

(Total for Question 19 = 1 mark)

TOTAL FOR SECTION A = 20 MARKS

DO NOT WRITE IN THIS AREA

DO NOT WRITE IN THIS AREA

DO NOT WRITE IN THIS AREA



DO NOT WRITE IN THIS AREA

DO NOT WRITE IN THIS AREA

DO NOT WRITE IN THIS AREA

**BLANK PAGE**



P 4 6 6 6 1 A 0 1 3 3 2

## SECTION B

**Answer ALL the questions. Write your answers in the spaces provided.**

**20** Vanadium exists in different oxidation states which can be interconverted using suitable oxidising and reducing agents.

(a) Use relevant standard electrode potential values, on page 14 of the Data Booklet, to complete the table below in which two  $E^\ominus$  values are missing.

(1)

Half-equation	$E^\ominus / \text{V}$
$\text{V}^{2+}(\text{aq}) + 2\text{e}^- \rightleftharpoons \text{V}(\text{s})$	
$\text{V}^{3+}(\text{aq}) + \text{e}^- \rightleftharpoons \text{V}^{2+}(\text{aq})$	
$\text{VO}^{2+}(\text{aq}) + 2\text{H}^+(\text{aq}) + \text{e}^- \rightleftharpoons \text{V}^{3+}(\text{aq}) + \text{H}_2\text{O}(\text{l})$	+0.34
$\text{I}_2(\text{aq}) + 2\text{e}^- \rightleftharpoons 2\text{I}^-(\text{aq})$	+0.54
$\text{VO}_2^+(\text{aq}) + 2\text{H}^+(\text{aq}) + \text{e}^- \rightleftharpoons \text{VO}^{2+}(\text{aq}) + \text{H}_2\text{O}(\text{l})$	+1.00

DO NOT WRITE IN THIS AREA

DO NOT WRITE IN THIS AREA

DO NOT WRITE IN THIS AREA



- (b) The standard electrode potential of  $V^{3+}(aq) + e^- \rightleftharpoons V^{2+}(aq)$  is measured using the apparatus below.

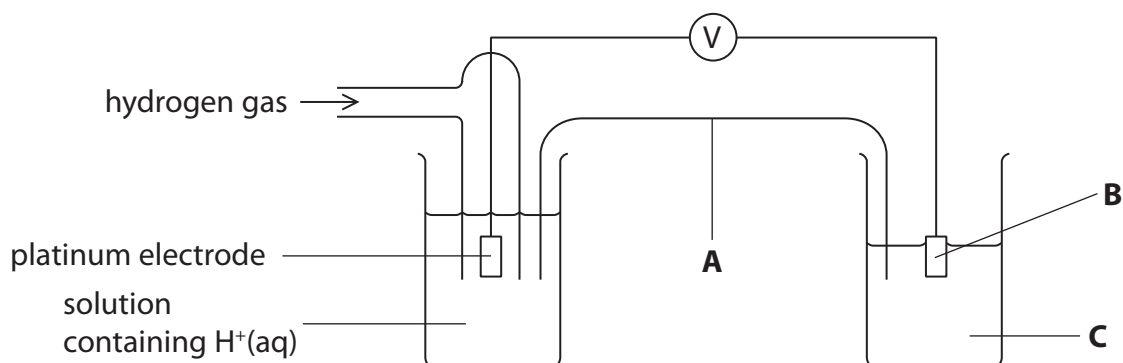

- (i) Identify, by name or formula, the substances needed in the salt bridge and the right-hand half-cell to measure the standard electrode potential.

(3)

**A** Salt bridge containing a solution of

**B** Electrode made of

**C** Solution containing

- (ii) State the **three** standard conditions needed for this measurement.

(2)

1 .....

2 .....

3 .....



\*(c) A solution containing iodide ions,  $I^-$ , was added to an acidified solution containing vanadium(V) ions,  $VO_2^+$ .

Predict the oxidation state of the vanadium ions left at the end of the reaction. Justify your prediction by calculating the  $E_{\text{cell}}^\ominus$  for any relevant reaction(s).

Write the ionic equation for any reaction(s) occurring. State symbols are not required.

(5)

.....

.....

.....

.....

.....

.....

.....

.....

.....

.....

.....

.....

.....

.....

.....

.....

.....

.....

.....

.....

.....

.....

.....

.....

(Total for Question 20 = 11 marks)





21 (a) The structures of 2-aminopropanoic acid and 3-aminopropanoic acid are shown.

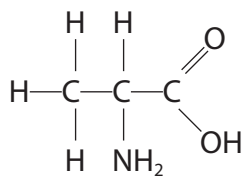

2-aminopropanoic acid

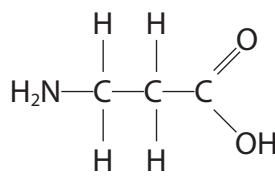

3-aminopropanoic acid

(i) Explain how the **low** resolution proton nmr spectra of these two amino acids differ. (2)

.....

.....

.....

.....

(ii) Explain whether or not 3-aminopropanoic acid is chiral. (1)

.....

.....

(iii) Write ionic equations for the reaction of 3-aminopropanoic acid with (2)

H<sup>+</sup> ions

OH<sup>-</sup> ions



(iv) Draw two repeat units of the polymer formed when 3-aminopropanoic acid polymerizes.

(1)

DO NOT WRITE IN THIS AREA

DO NOT WRITE IN THIS AREA

DO NOT WRITE IN THIS AREA

(b) The food colouring E110 is also known as Sunset Yellow.

It can be synthesised as shown below.

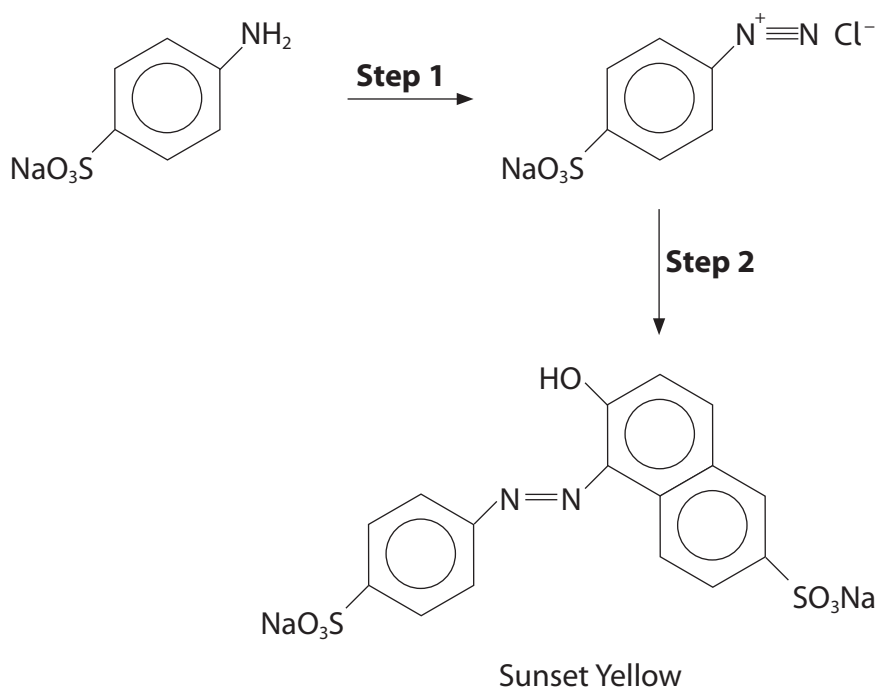

(i) Give the reagents and condition for **Step 1**.

(2)



(ii) Draw the structure of the reagent needed for **Step 2**.

(1)

(iii) Explain why Sunset Yellow can exist as geometric isomers.

(1)

\*(iv) Describe the essential steps of the method that you would use to prepare a pure, dry sample of the solid Sunset Yellow from an impure sample of the food colouring. You may assume that ethanol is a suitable solvent for this method.

(4)

DO NOT WRITE IN THIS AREA

DO NOT WRITE IN THIS AREA

DO NOT WRITE IN THIS AREA



P 4 6 6 6 1 A 0 1 9 3 2

(v) Suggest how you could check that a sample of Sunset Yellow is pure.

(1)

DO NOT WRITE IN THIS AREA

DO NOT WRITE IN THIS AREA

DO NOT WRITE IN THIS AREA

(c) Explain how a chemist could use phenylmethanol to synthesise a sample of benzamide in three steps.

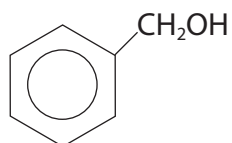

phenylmethanol

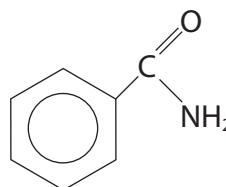

benzamide

Include the reagents for the steps in the synthesis and draw the structures of **all** the intermediates.

(5)

(Total for Question 21 = 20 marks)



DO NOT WRITE IN THIS AREA

DO NOT WRITE IN THIS AREA

DO NOT WRITE IN THIS AREA

**22** Copper and zinc are both in the d-block of the Periodic Table. Copper forms compounds that contain  $\text{Cu}^+$  and  $\text{Cu}^{2+}$  ions but zinc only forms compounds that contain  $\text{Zn}^{2+}$  ions.

(a) Complete the electronic configurations of the  $\text{Cu}^{2+}$  ions and  $\text{Zn}^{2+}$  ions and hence explain why copper is classified as a transition metal but zinc is not.

(2)

$\text{Cu}^{2+}$  [Ar] .....

$\text{Zn}^{2+}$  [Ar] .....

.....  
.....  
.....  
.....

(b) Some photochromic glasses contain silver(I) and copper(I) chlorides.

Explain, with the aid of an equation, why these photochromic glasses go darker in sunlight.

(2)

.....  
.....  
.....  
.....



- (c) Copper forms a complex ion with the formula  $[\text{CuCl}_4]^{2-}$ . This has the same shape as  $[\text{Pt}(\text{NH}_3)_2\text{Cl}_2]$ .

Draw the shape of the  $[\text{CuCl}_4]^{2-}$  ion and state the type of bonding between the ligands and the metal ion.

(2)

Shape

Bonding.....

- (d) The  $[\text{CuCl}_2]^-$  ion is formed by boiling a solution of copper(II) chloride with copper turnings and concentrated hydrochloric acid.

(i) Write an equation for this reaction. State symbols are not required.

(1)

(ii) State the meaning of the term **disproportionation** and explain whether or not this reaction to form the  $[\text{CuCl}_2]^-$  ion is a disproportionation reaction.

(2)

.....

.....

.....

.....

.....

.....



(iii) Explain why the  $[\text{CuCl}_2]^-$  ions are colourless.

(2)

.....

.....

.....

.....

.....

.....

(e) Copper(II) sulfate solution reacts with aqueous sodium hydroxide and with aqueous ammonia.

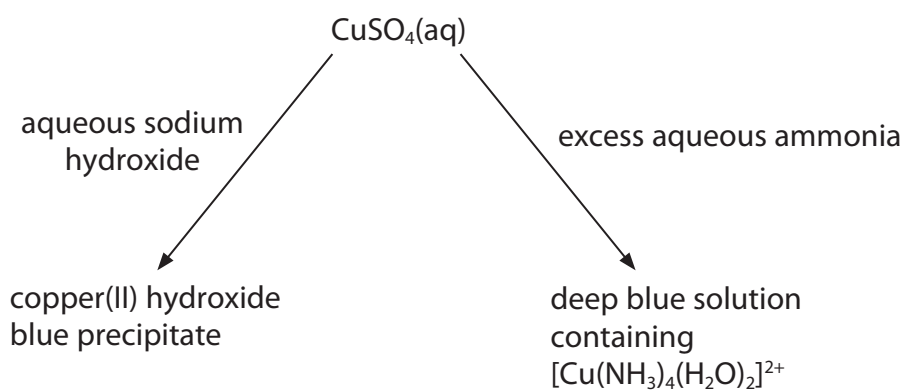

(i) Write the **ionic** equation for the reaction of copper(II) sulfate solution with aqueous sodium hydroxide. Include state symbols.

(1)

(ii) State the type of reaction occurring overall when excess aqueous ammonia is added to copper(II) sulfate solution.

(1)

.....

DO NOT WRITE IN THIS AREA

DO NOT WRITE IN THIS AREA

DO NOT WRITE IN THIS AREA



P 4 6 6 6 1 A 0 2 3 3 2

- (f) 1,2-diaminoethane is a bidentate ligand. It reacts with copper(II) ions in aqueous solution.

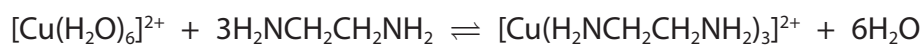

- (i) State what is meant by the term **bidentate**. (1)

- (ii) Explain, in terms of entropy, why the reaction takes place. (2)

(Total for Question 22 = 16 marks)

**TOTAL FOR SECTION B = 47 MARKS**





## SECTION C

Answer ALL the questions. Write your answers in the spaces provided.

23

### Analgesics

Analgesics are taken to relieve the symptoms of pain.

#### Paracetamol

This has been synthesised in a three-step process since the 1950s.

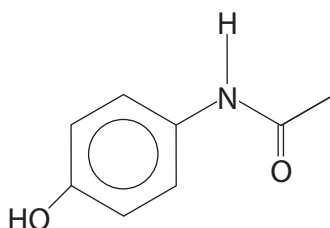

#### Ibuprofen

This was first synthesised in the 1960s from propanoic acid. That process involved six steps and produced more waste than the required drug.

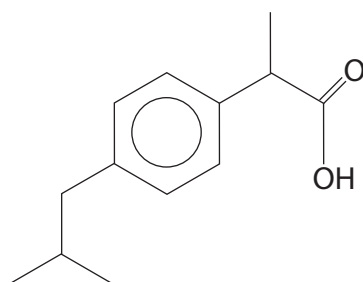

It is now manufactured in a three-step process.

Some data about these two analgesics are given in the table below.

Analgesic	Molecular formula	Molar mass / g mol <sup>-1</sup>
paracetamol	C <sub>8</sub> H <sub>9</sub> NO <sub>2</sub>	151
ibuprofen	C <sub>13</sub> H <sub>18</sub> O <sub>2</sub>	206



(a) **Name** the functional group in paracetamol, other than the phenol group.

(1)

(b) Paracetamol is made from phenol in a three-step process.

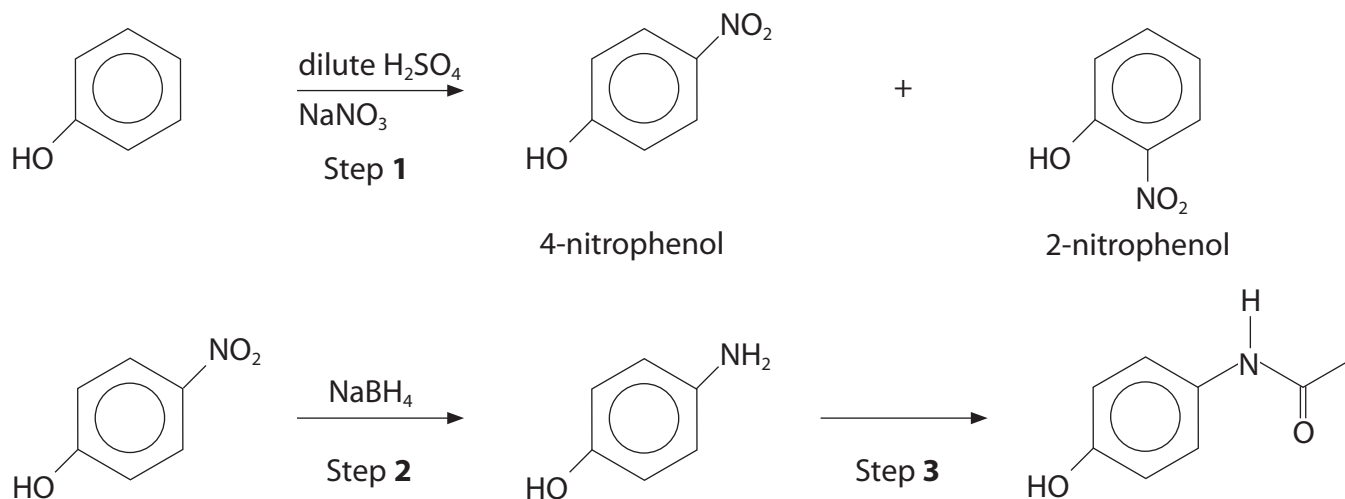

(i) In a typical nitration of an arene, the electrophile is formed as shown below.

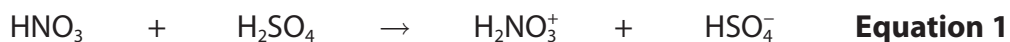

.....



Identify the acid-base conjugate pairs in **Equation 1**. Write your answers on the dotted lines under the equation.

(1)



(ii) Give a mechanism for the nitration of phenol by  $\text{NO}_2^+$  to form 4-nitrophenol.

(3)

(iii) Explain why phenol is nitrated much more readily than benzene.

(2)

(iv) State the type of reaction taking place in Step 2.

(1)

(v) Suggest a reagent for Step 3.

(1)

DO NOT WRITE IN THIS AREA

DO NOT WRITE IN THIS AREA

DO NOT WRITE IN THIS AREA



P 4 6 6 6 1 A 0 2 7 3 2

(vi) 2-nitrophenol has a melting temperature of 46 °C and 4-nitrophenol has a melting temperature of 114 °C.

Suggest, in terms of intermolecular forces, why these two compounds have different melting temperatures.

(2)

.....

.....

.....

.....

.....

DO NOT WRITE IN THIS AREA

DO NOT WRITE IN THIS AREA

DO NOT WRITE IN THIS AREA

(c) Paracetamol can be hydrolysed to form 4-aminophenol and ethanoic acid.

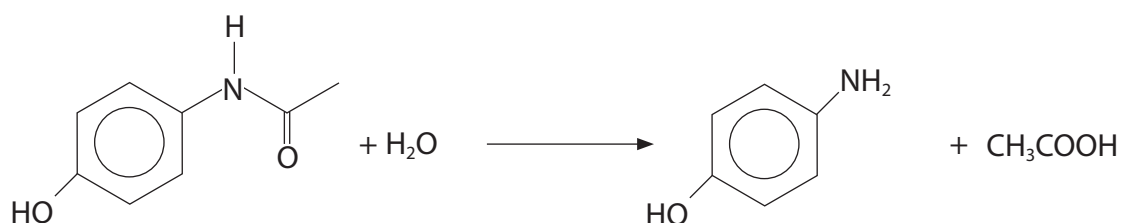

The amount of 4-aminophenol produced can be determined using a redox titration. The half-equation for the oxidation of 4-aminophenol is given below.

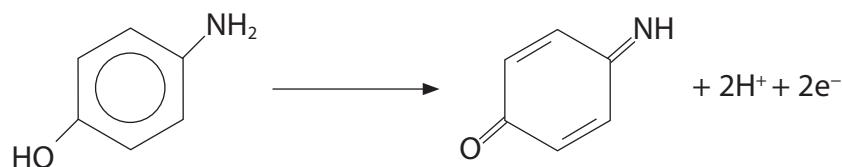

The oxidizing agent is ammonium cerium(IV) sulfate and ferroin indicator is used to detect the end-point of the titration. During the reaction, the  $\text{Ce}^{4+}$  ions are reduced to  $\text{Ce}^{3+}$  ions.

(i) Write the overall equation for the reaction between  $\text{Ce}^{4+}$  ions and 4-aminophenol.

(1)



(ii) In an experiment, 0.500 g of a tablet containing paracetamol was hydrolysed and the solution was made up to 100 cm<sup>3</sup>.

20.0 cm<sup>3</sup> portions of the resulting solution were titrated with 0.100 mol dm<sup>-3</sup> ammonium cerium(IV) sulfate solution.

The mean titre was 12.60 cm<sup>3</sup>.

Calculate the percentage, by mass, of paracetamol in the tablet.

(5)

DO NOT WRITE IN THIS AREA

DO NOT WRITE IN THIS AREA

DO NOT WRITE IN THIS AREA



P 4 6 6 6 1 A 0 2 9 3 2

(d) (i) Identify the chiral carbon atom in ibuprofen with an asterisk (\*).

(1)

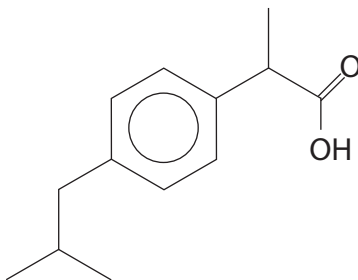

(ii) Suggest a problem in the manufacture of a single isomer of a chiral drug and describe a way that the pharmaceutical industry might overcome this problem.

(2)

.....

.....

.....

.....

.....

.....

(e) Ibuprofen was originally made in a six-step process but is now made in a three-step process.

Suggest a specific environmental reason why the manufacturing process was changed.

(1)

.....

.....

.....



(f) Ibuprofen is not very soluble in water. It can be made into an ionic, soluble salt by reacting it with lysine.

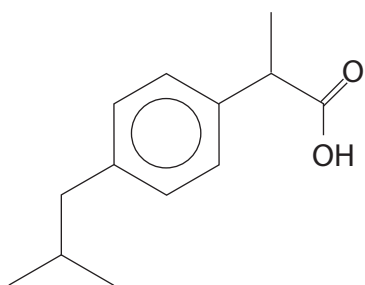

Ibuprofen

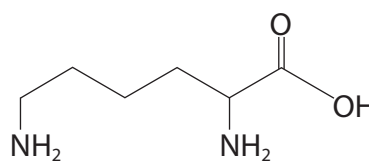

Lysine

Draw the structures of **both** the cation and the anion in the soluble salt formed when ibuprofen reacts with lysine.

(2)

(Total for Question 23 = 23 marks)

TOTAL FOR SECTION C = 23 MARKS

TOTAL FOR PAPER = 90 MARKS



# The Periodic Table of Elements

	1	2	3	4	5	6	7	0 (8)															
(1)	6.9 <b>Li</b> lithium 3	9.0 <b>Be</b> beryllium 4	<table border="1"> <tr> <td>10.8 <b>B</b> boron 5</td> <td>12.0 <b>C</b> carbon 6</td> <td>14.0 <b>N</b> nitrogen 7</td> <td>16.0 <b>O</b> oxygen 8</td> <td>19.0 <b>F</b> fluorine 9</td> <td>20.2 <b>Ne</b> neon 10</td> </tr> </table>						10.8 <b>B</b> boron 5	12.0 <b>C</b> carbon 6	14.0 <b>N</b> nitrogen 7	16.0 <b>O</b> oxygen 8	19.0 <b>F</b> fluorine 9	20.2 <b>Ne</b> neon 10	4.0 <b>He</b> helium 2								
10.8 <b>B</b> boron 5	12.0 <b>C</b> carbon 6	14.0 <b>N</b> nitrogen 7	16.0 <b>O</b> oxygen 8	19.0 <b>F</b> fluorine 9	20.2 <b>Ne</b> neon 10																		
(2)	23.0 <b>Na</b> sodium 11	24.3 <b>Mg</b> magnesium 12	<table border="1"> <tr> <td>27.0 <b>Al</b> aluminium 13</td> <td>28.1 <b>Si</b> silicon 14</td> <td>31.0 <b>P</b> phosphorus 15</td> <td>32.1 <b>S</b> sulfur 16</td> <td>35.5 <b>Cl</b> chlorine 17</td> <td>39.9 <b>Ar</b> argon 18</td> </tr> </table>						27.0 <b>Al</b> aluminium 13	28.1 <b>Si</b> silicon 14	31.0 <b>P</b> phosphorus 15	32.1 <b>S</b> sulfur 16	35.5 <b>Cl</b> chlorine 17	39.9 <b>Ar</b> argon 18									
27.0 <b>Al</b> aluminium 13	28.1 <b>Si</b> silicon 14	31.0 <b>P</b> phosphorus 15	32.1 <b>S</b> sulfur 16	35.5 <b>Cl</b> chlorine 17	39.9 <b>Ar</b> argon 18																		
(3)	39.1 <b>K</b> potassium 19	40.1 <b>Ca</b> calcium 20	88.9 <b>Sc</b> scandium 21	47.9 <b>Ti</b> titanium 22	50.9 <b>V</b> vanadium 23	52.0 <b>Cr</b> chromium 24	54.9 <b>Mn</b> manganese 25	55.8 <b>Fe</b> iron 26	58.9 <b>Co</b> cobalt 27	58.7 <b>Ni</b> nickel 28	63.5 <b>Cu</b> copper 29	65.4 <b>Zn</b> zinc 30	69.7 <b>Ga</b> gallium 31	72.6 <b>Ge</b> germanium 32	74.9 <b>As</b> arsenic 33	79.0 <b>Se</b> selenium 34	79.9 <b>Br</b> bromine 35	83.8 <b>Kr</b> krypton 36					
(4)	85.5 <b>Rb</b> rubidium 37	87.6 <b>Sr</b> strontium 38	88.9 <b>Y</b> yttrium 39	91.2 <b>Zr</b> zirconium 40	92.9 <b>Nb</b> niobium 41	95.9 <b>Mo</b> molybdenum 42	[98] <b>Tc</b> technetium 43	101.1 <b>Ru</b> ruthenium 44	102.9 <b>Rh</b> rhodium 45	106.4 <b>Pd</b> palladium 46	107.9 <b>Ag</b> silver 47	112.4 <b>Cd</b> cadmium 48	114.8 <b>In</b> indium 49	118.7 <b>Sn</b> tin 50	121.8 <b>Sb</b> antimony 51	127.6 <b>Te</b> tellurium 52	126.9 <b>I</b> iodine 53	131.3 <b>Xe</b> xenon 54					
(5)	132.9 <b>Cs</b> caesium 55	137.3 <b>Ba</b> barium 56	138.9 <b>La*</b> lanthanum 57	178.5 <b>Hf</b> hafnium 72	180.9 <b>Ta</b> tantalum 73	183.8 <b>W</b> tungsten 74	186.2 <b>Re</b> rhenium 75	190.2 <b>Os</b> osmium 76	192.2 <b>Ir</b> iridium 77	195.1 <b>Pt</b> platinum 78	197.0 <b>Au</b> gold 79	200.6 <b>Hg</b> mercury 80	204.4 <b>Tl</b> thallium 81	207.2 <b>Pb</b> lead 82	209.0 <b>Bi</b> bismuth 83	[209] <b>Po</b> polonium 84	[210] <b>At</b> astatine 85	[222] <b>Rn</b> radon 86					
(6)	[223] <b>Fr</b> francium 87	[226] <b>Ra</b> radium 88	[227] <b>Ac*</b> actinium 89	[261] <b>Rf</b> rutherfordium 104	[262] <b>Db</b> dubnium 105	[266] <b>Sg</b> seaborgium 106	[264] <b>Bh</b> bohrium 107	[277] <b>Hs</b> hassium 108	[268] <b>Mt</b> meitnerium 109	[271] <b>Ds</b> darmstadtium 110	[272] <b>Rg</b> roentgenium 111	Elements with atomic numbers 112-116 have been reported but not fully authenticated											
(7)	[232] <b>Th</b> thorium 90	[231] <b>Pa</b> protactinium 91	[237] <b>Np</b> neptunium 93	[242] <b>Pu</b> plutonium 94	[243] <b>Am</b> americium 95	[247] <b>Cm</b> curium 96	[251] <b>Cf</b> californium 98	[254] <b>Es</b> einsteinium 99	[253] <b>Fm</b> fermium 100	[256] <b>Md</b> mendelevium 101	[254] <b>No</b> nobelium 102	[257] <b>Lr</b> lawrencium 103	[257] <b>Lu</b> lutetium 71	[257] <b>Yb</b> ytterbium 70	[256] <b>Tm</b> thulium 69	[253] <b>Er</b> erbium 68	[254] <b>Hf</b> holmium 67	[256] <b>Dy</b> dysprosium 66	[257] <b>Ho</b> holmium 67	[256] <b>Er</b> erbium 68	[257] <b>Tm</b> thulium 69	[256] <b>Yb</b> ytterbium 70	[257] <b>Lu</b> lutetium 71
(8)	[232] <b>Th</b> thorium 90	[231] <b>Pa</b> protactinium 91	[237] <b>Np</b> neptunium 93	[242] <b>Pu</b> plutonium 94	[243] <b>Am</b> americium 95	[247] <b>Cm</b> curium 96	[251] <b>Cf</b> californium 98	[254] <b>Es</b> einsteinium 99	[253] <b>Fm</b> fermium 100	[256] <b>Md</b> mendelevium 101	[254] <b>No</b> nobelium 102	[257] <b>Lr</b> lawrencium 103	[257] <b>Lu</b> lutetium 71	[257] <b>Yb</b> ytterbium 70	[256] <b>Tm</b> thulium 69	[253] <b>Er</b> erbium 68	[254] <b>Hf</b> holmium 67	[256] <b>Dy</b> dysprosium 66	[257] <b>Ho</b> holmium 67	[256] <b>Er</b> erbium 68	[257] <b>Tm</b> thulium 69	[256] <b>Yb</b> ytterbium 70	[257] <b>Lu</b> lutetium 71

\* Lanthanide series

\* Actinide series

DO NOT WRITE IN THIS AREA

DO NOT WRITE IN THIS AREA

DO NOT WRITE IN THIS AREA

